

# Assembly manual

## catalog

1 Assenbly frame.....	3
2 Assembly X axis and Y axis.....	31
3 Assembly Z axis.....	90
4 Assembly Y siwtch and Z switch.....	129
5 Assembly feeder motor.....	139
6 Assembly board,LCD and power supply.....	152
7 Connect cable.....	167

Thank you for your kind support to choose our product!

When you use the printer, meet some problems, pls contact us.

Email : FlsunService@163.com

Skype : FLSUN Technical Support

pls visit the Facebook group, many people could help solve problem and share ideas.

the Facebook group link as follow:

<https://touch.facebook.com/groups/511992158981791?ref=bookmarks>

1,If you are satisfied with Kossel 3d printer kits, please leave a positive feedback to us, thank you so much for your kindness.

2,If you are not satisfied for any reason, please contact us before leaving a negative feedback(any negative review no longer be changed again),we will work together with you to help you solve any problem until you are satisfied

# key parts show

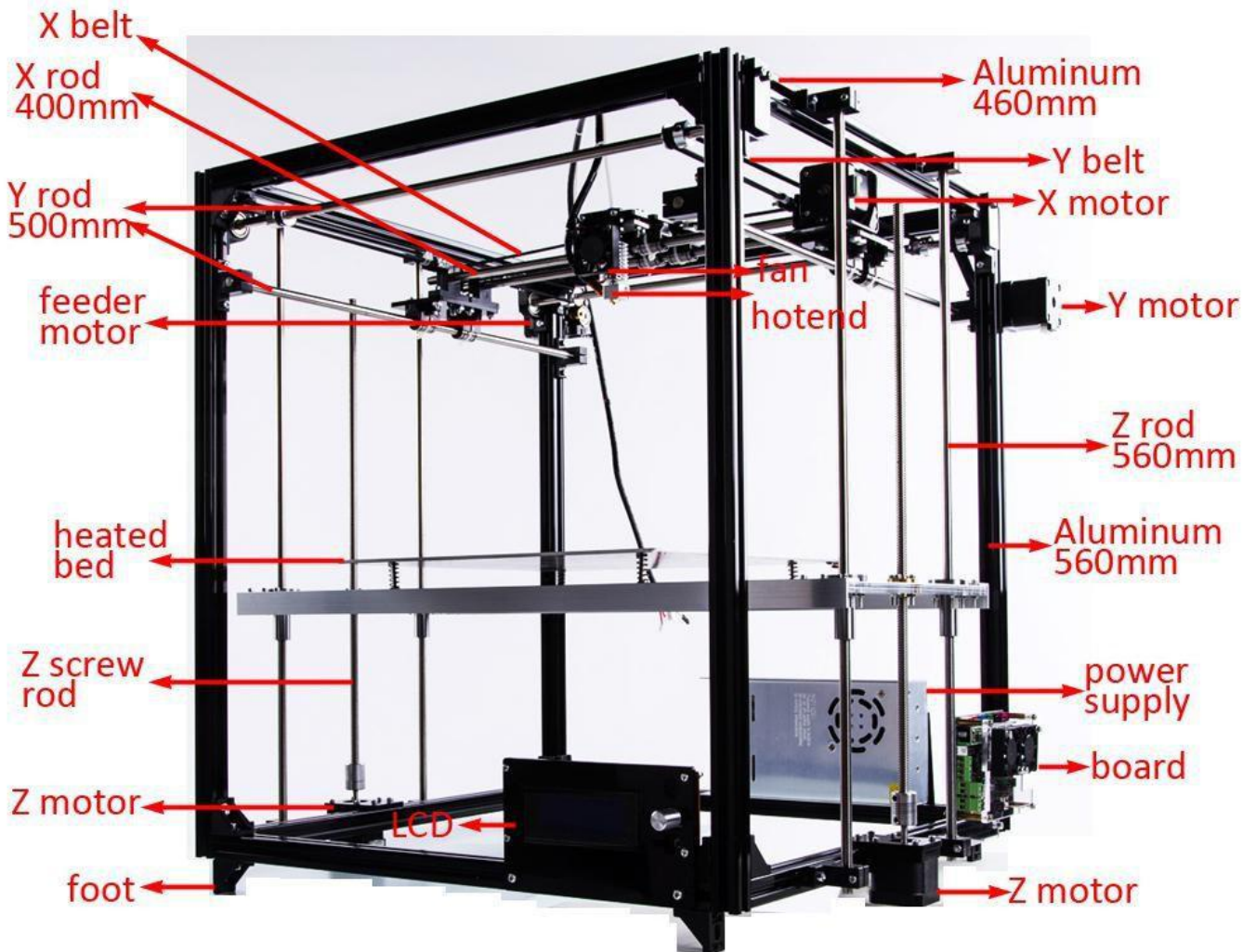

# 1 Assenbly frame

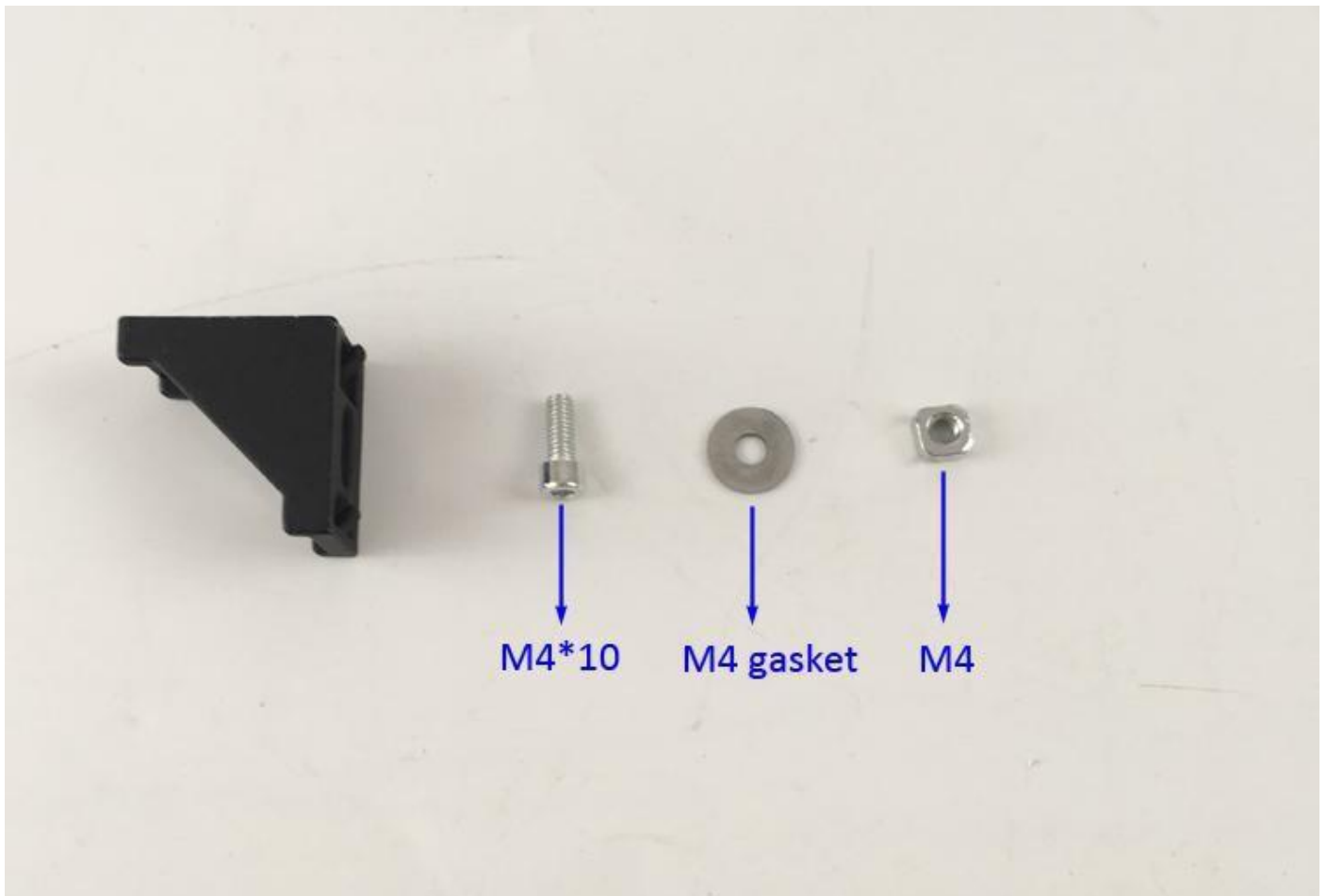

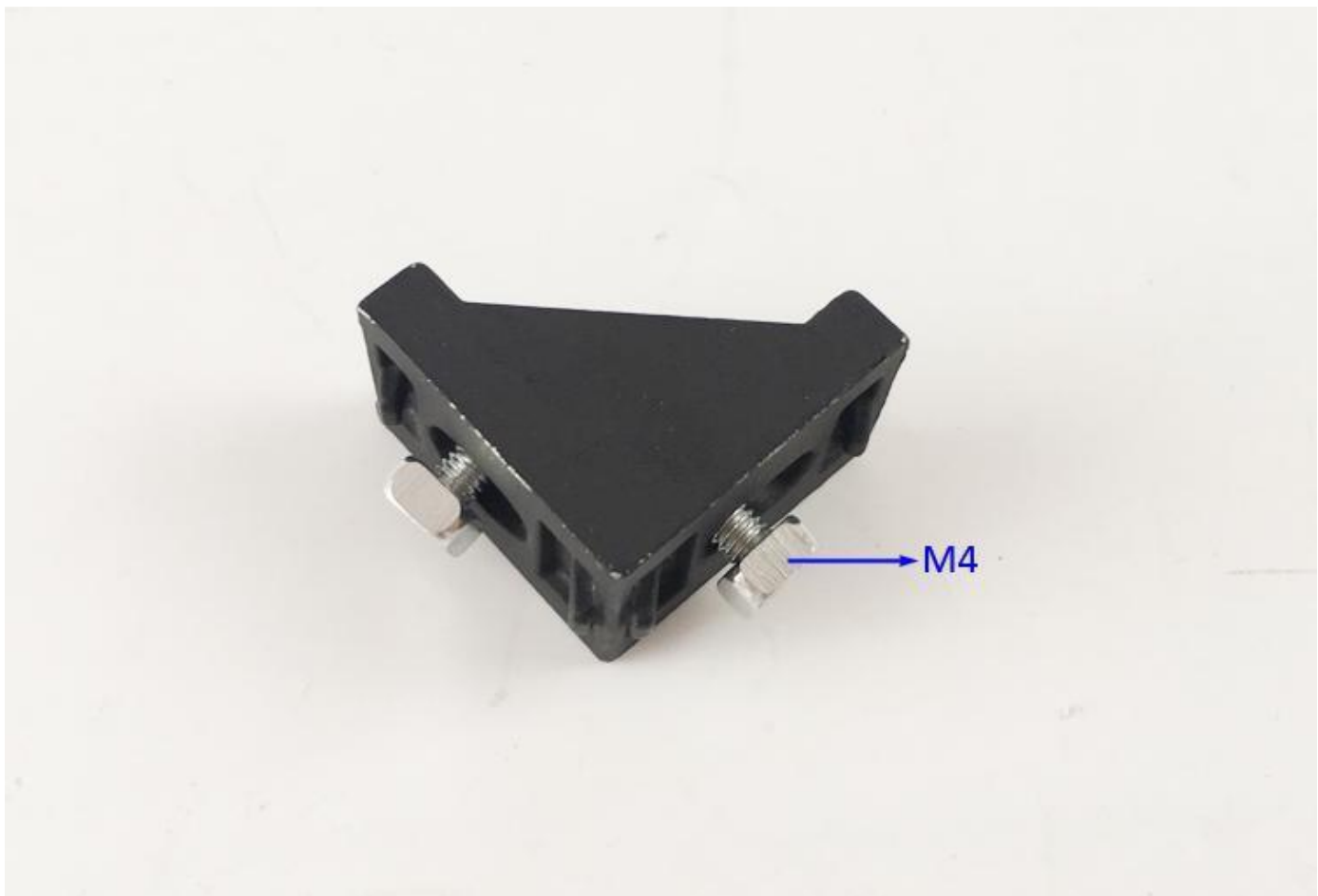
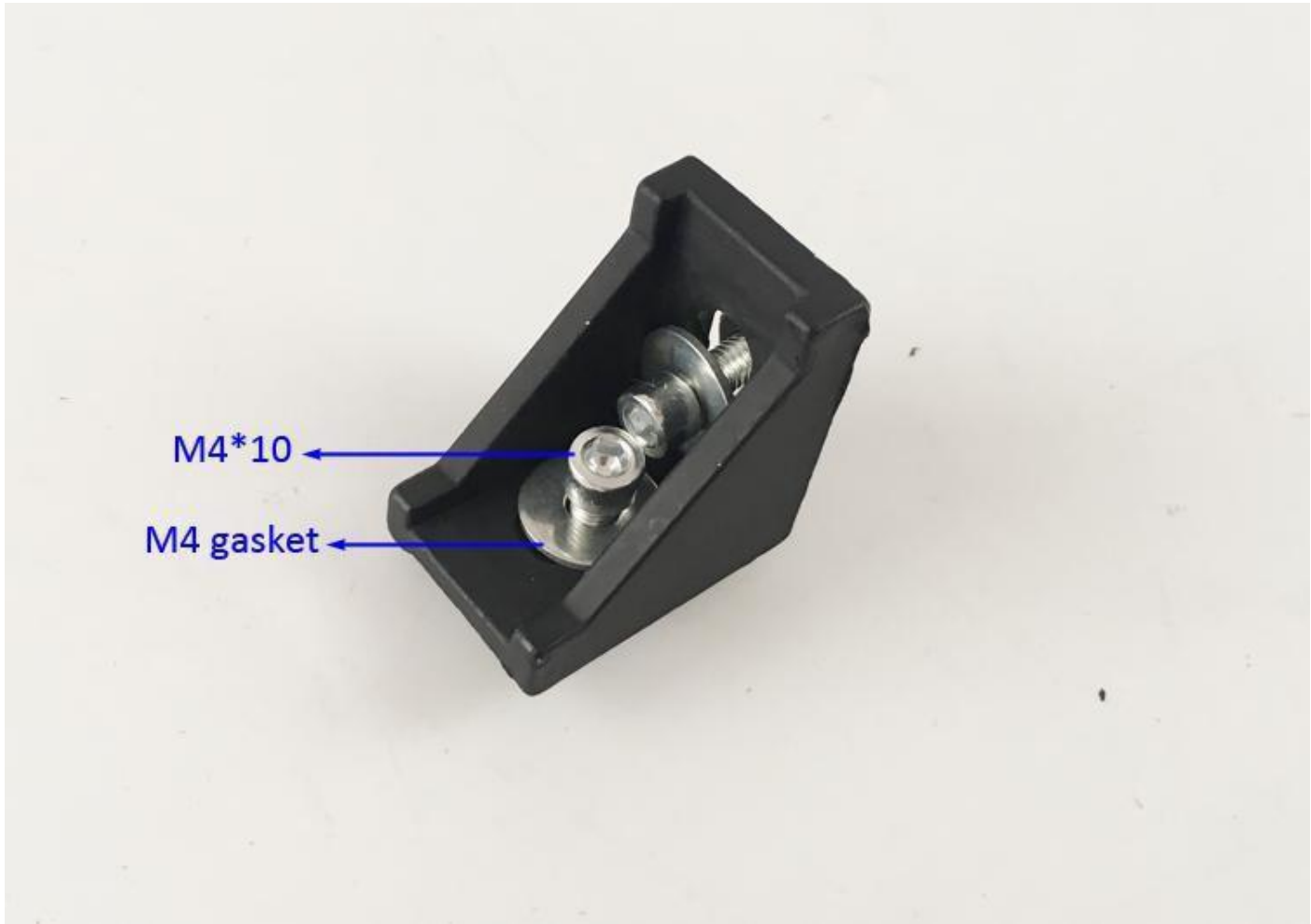

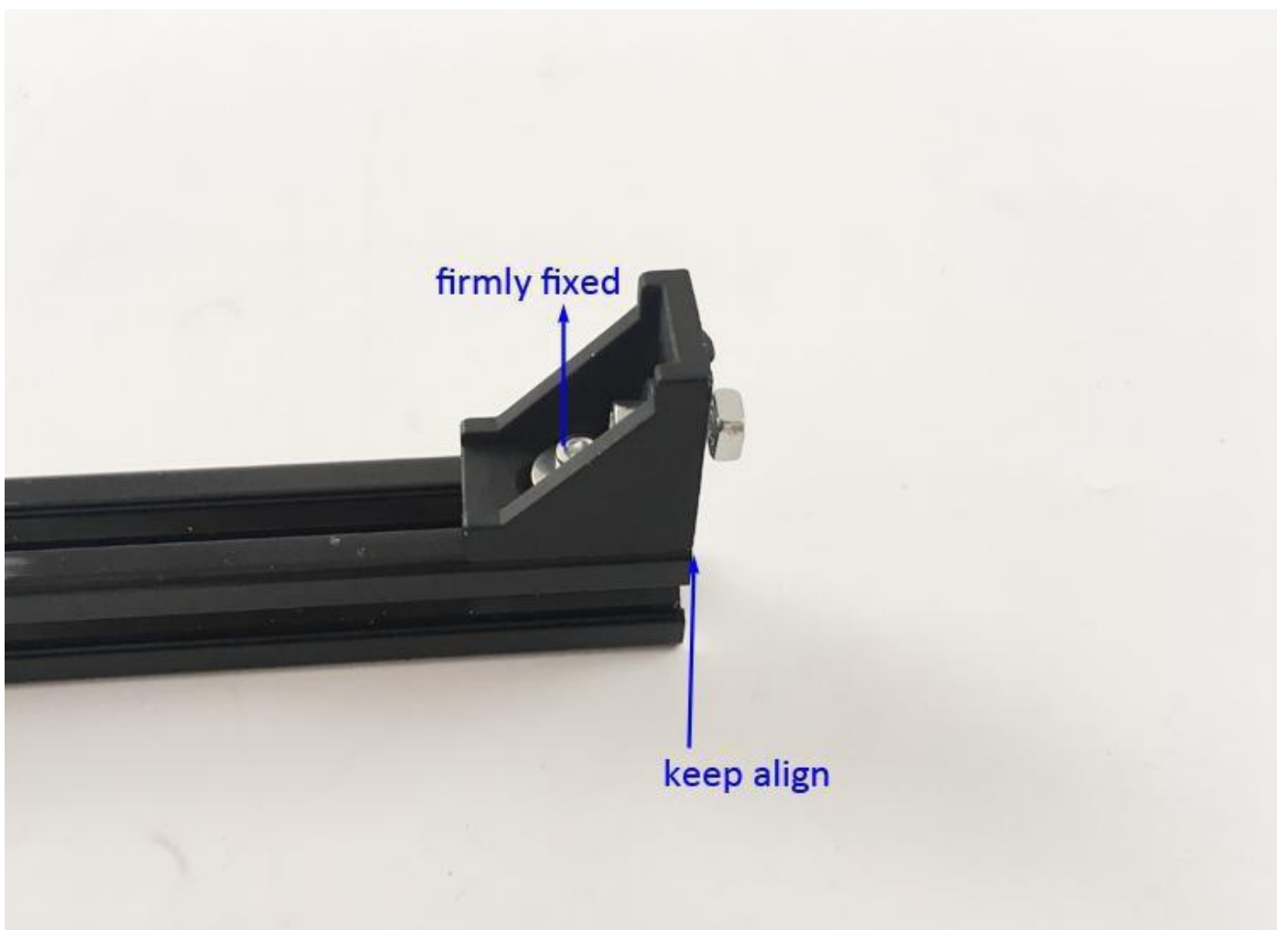
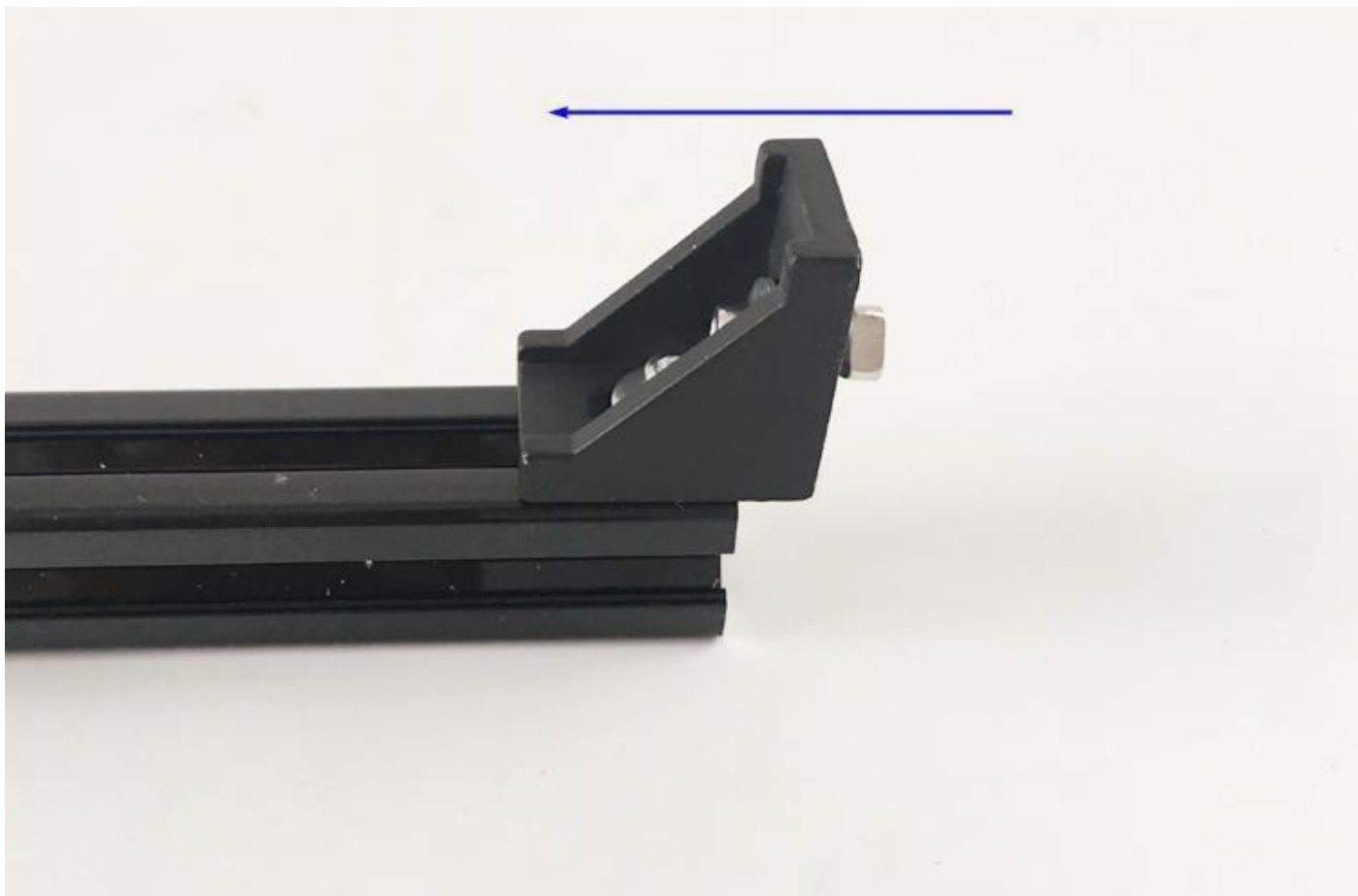

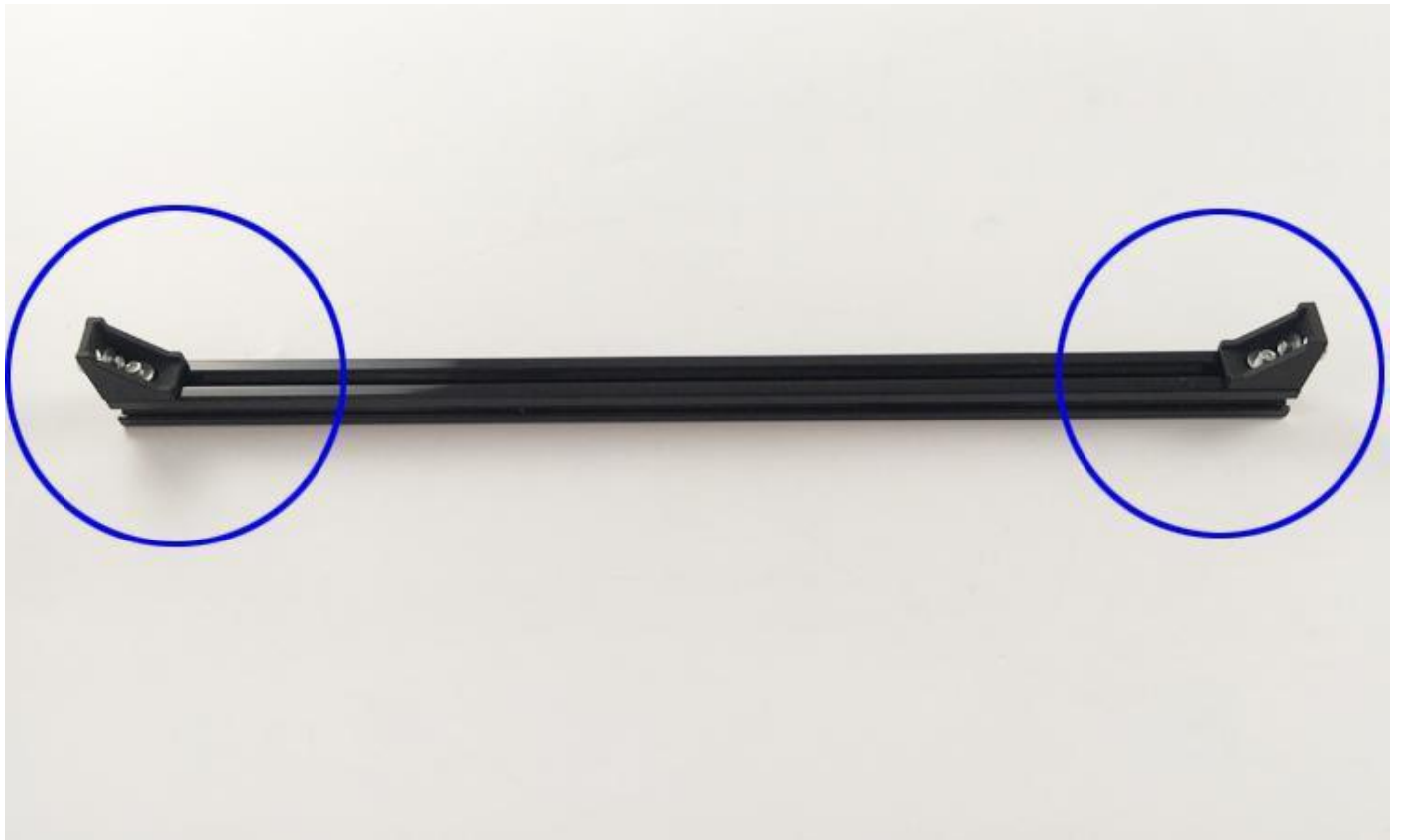





560 mm

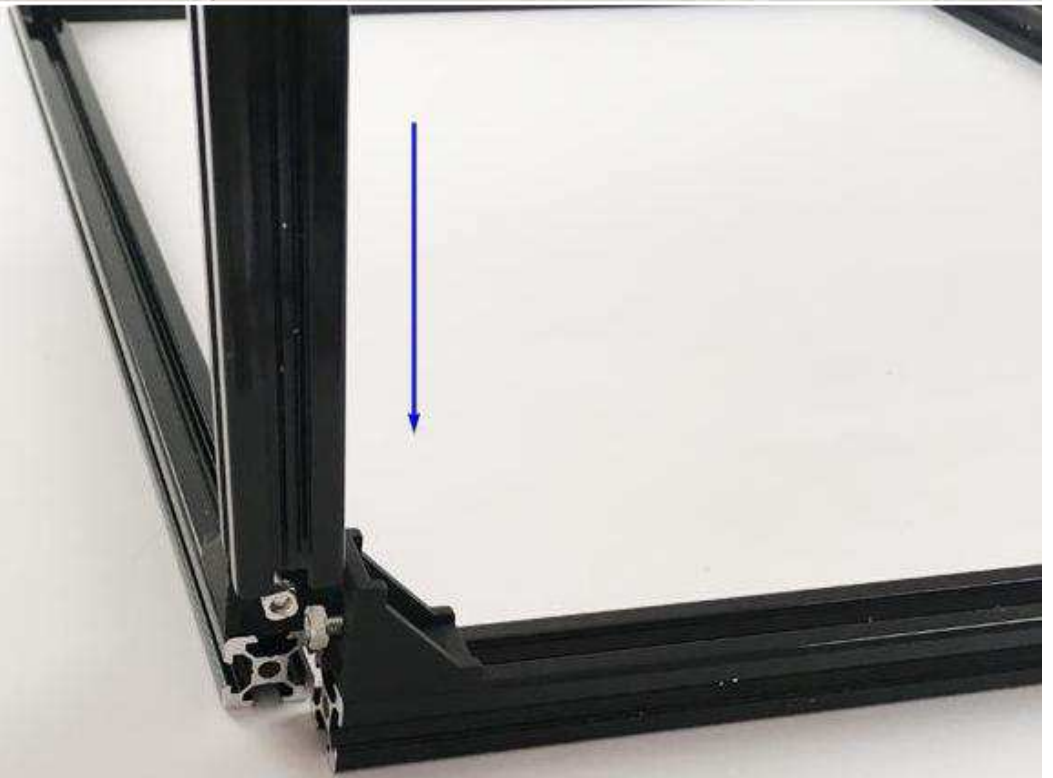







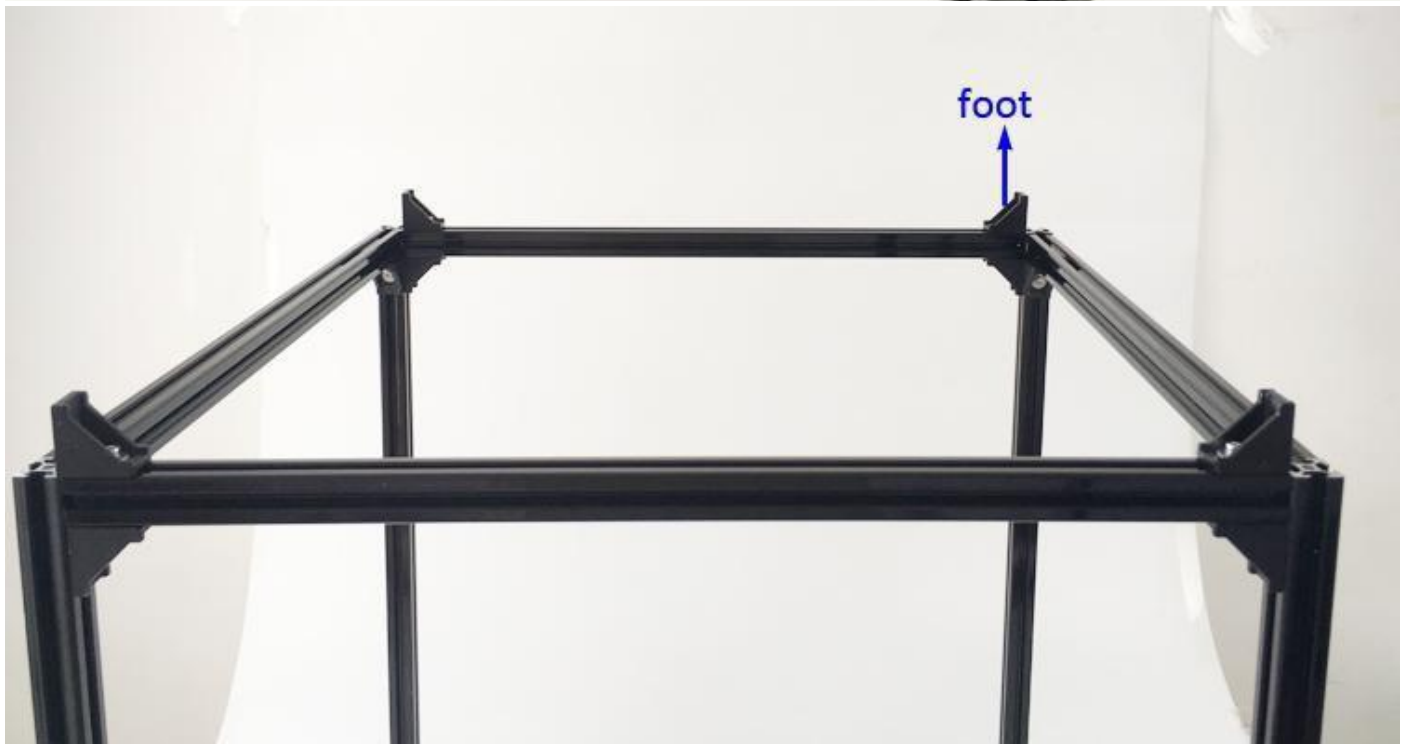



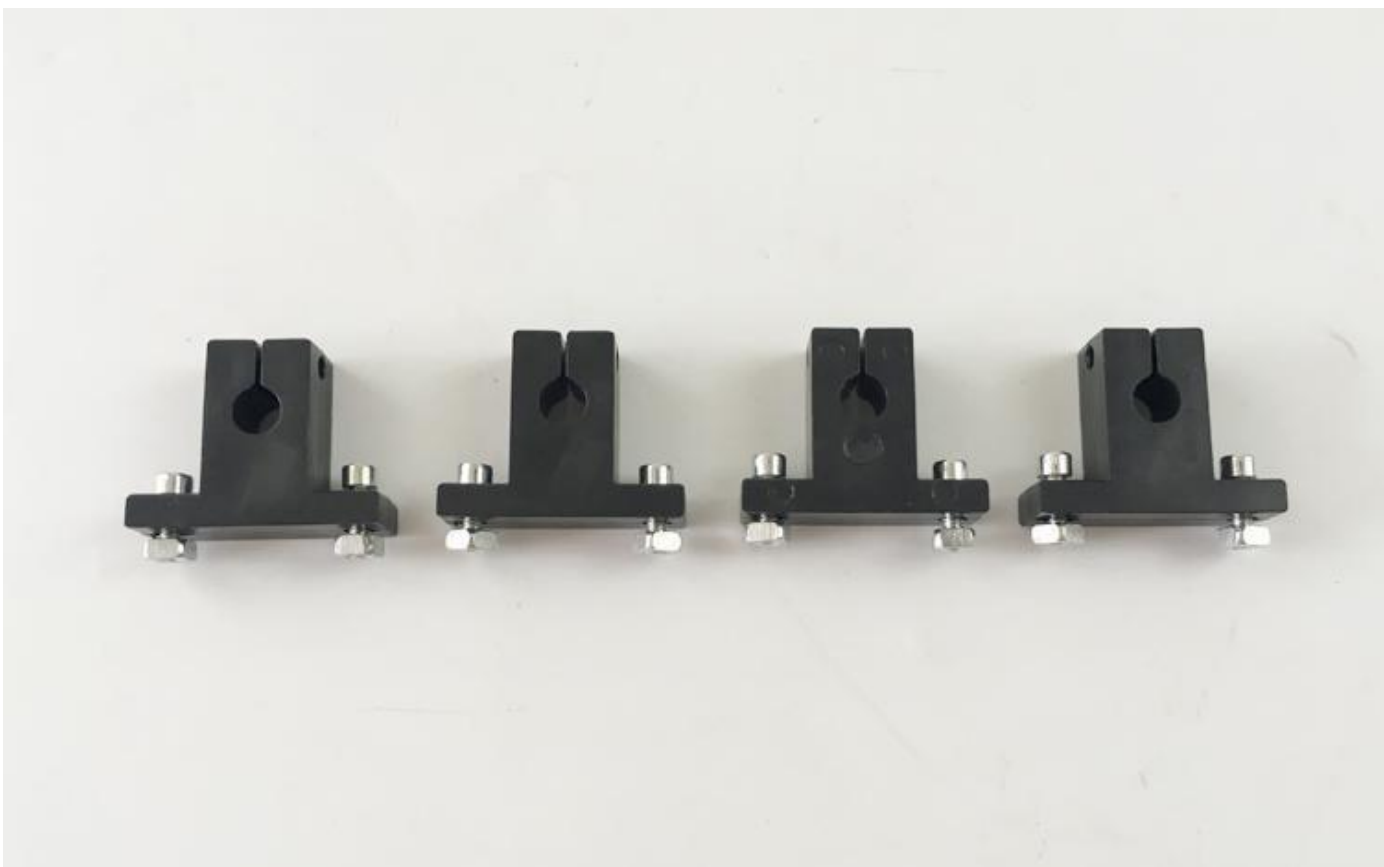
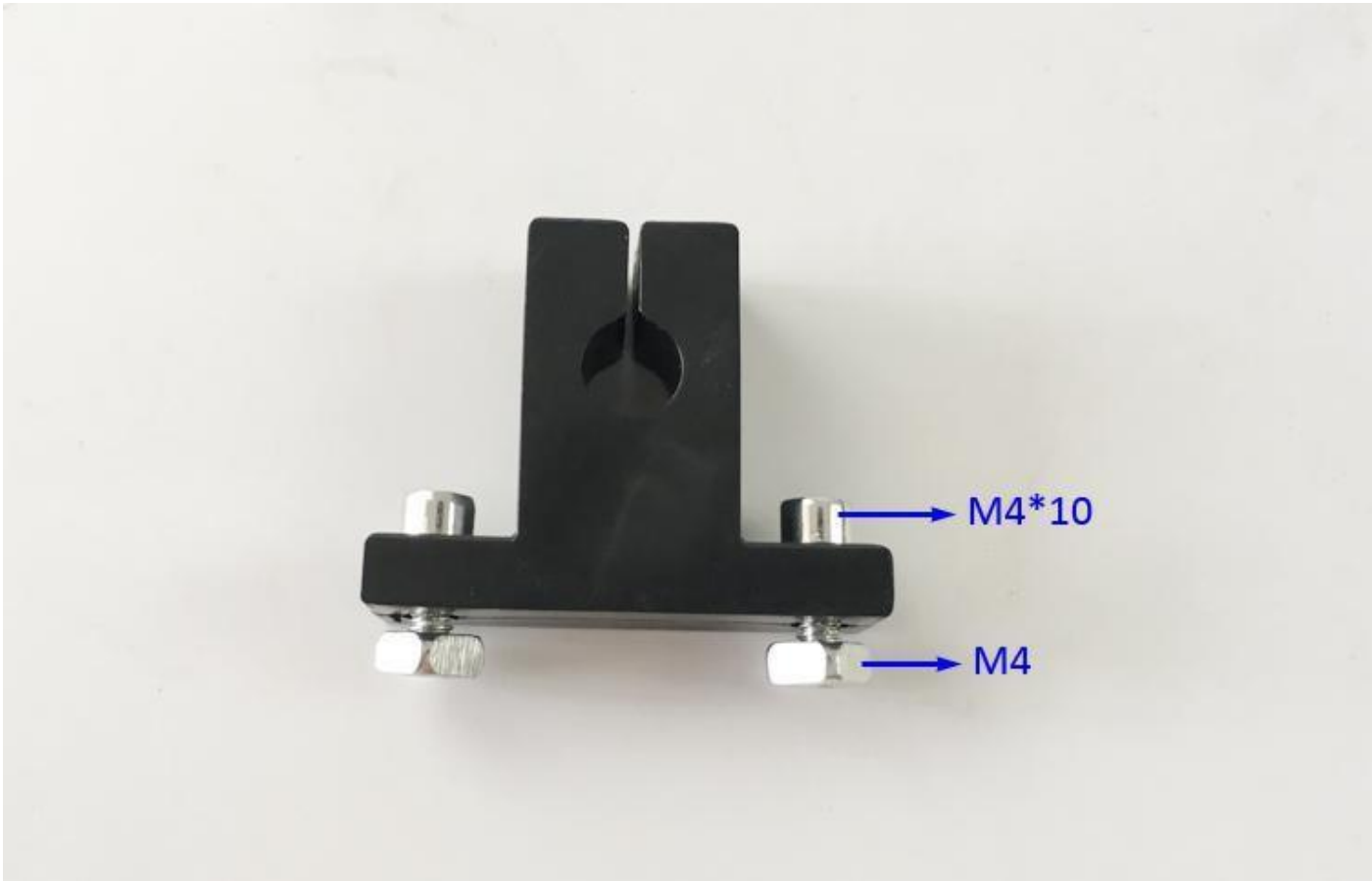

positioning block 80mm

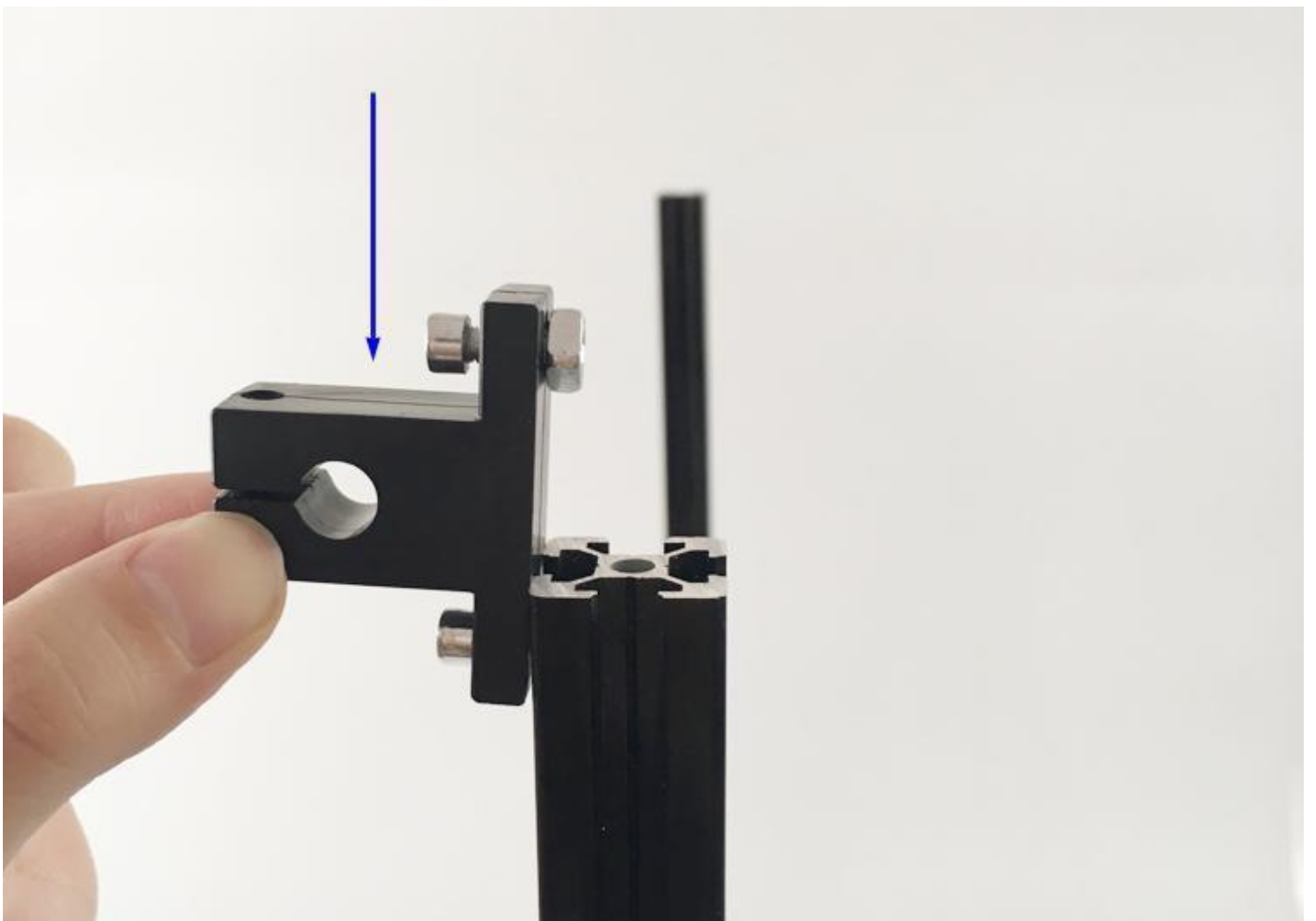



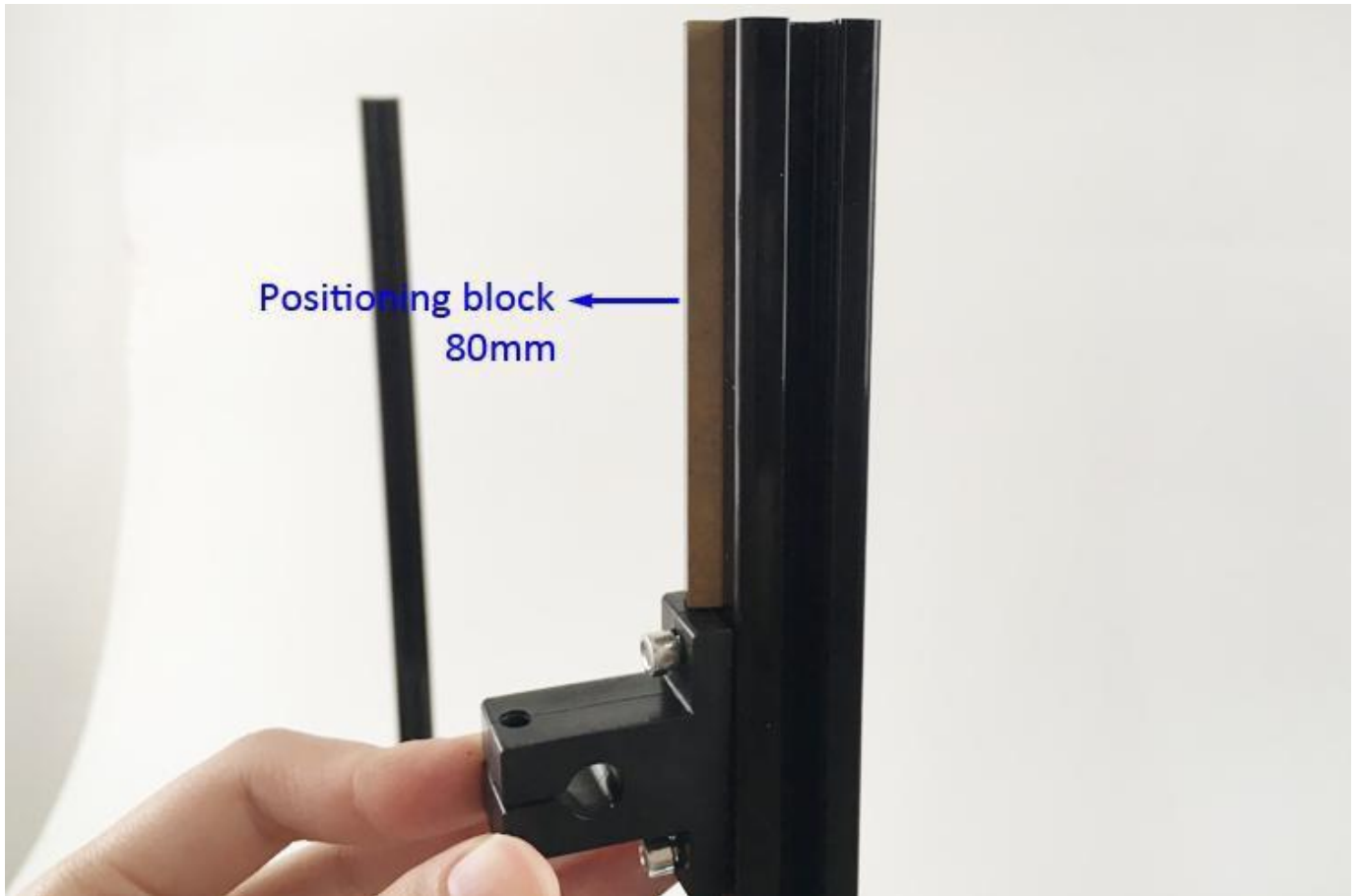
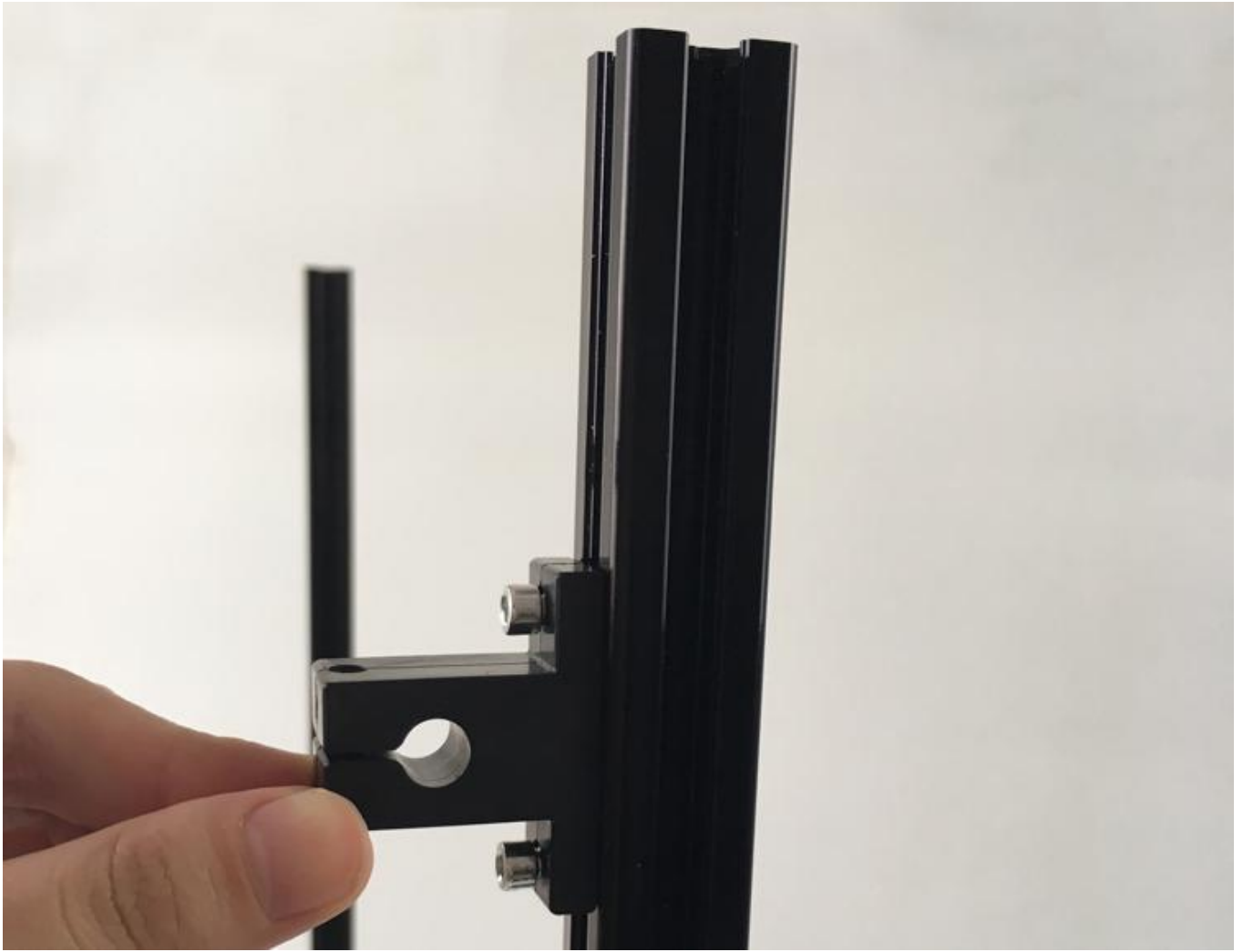

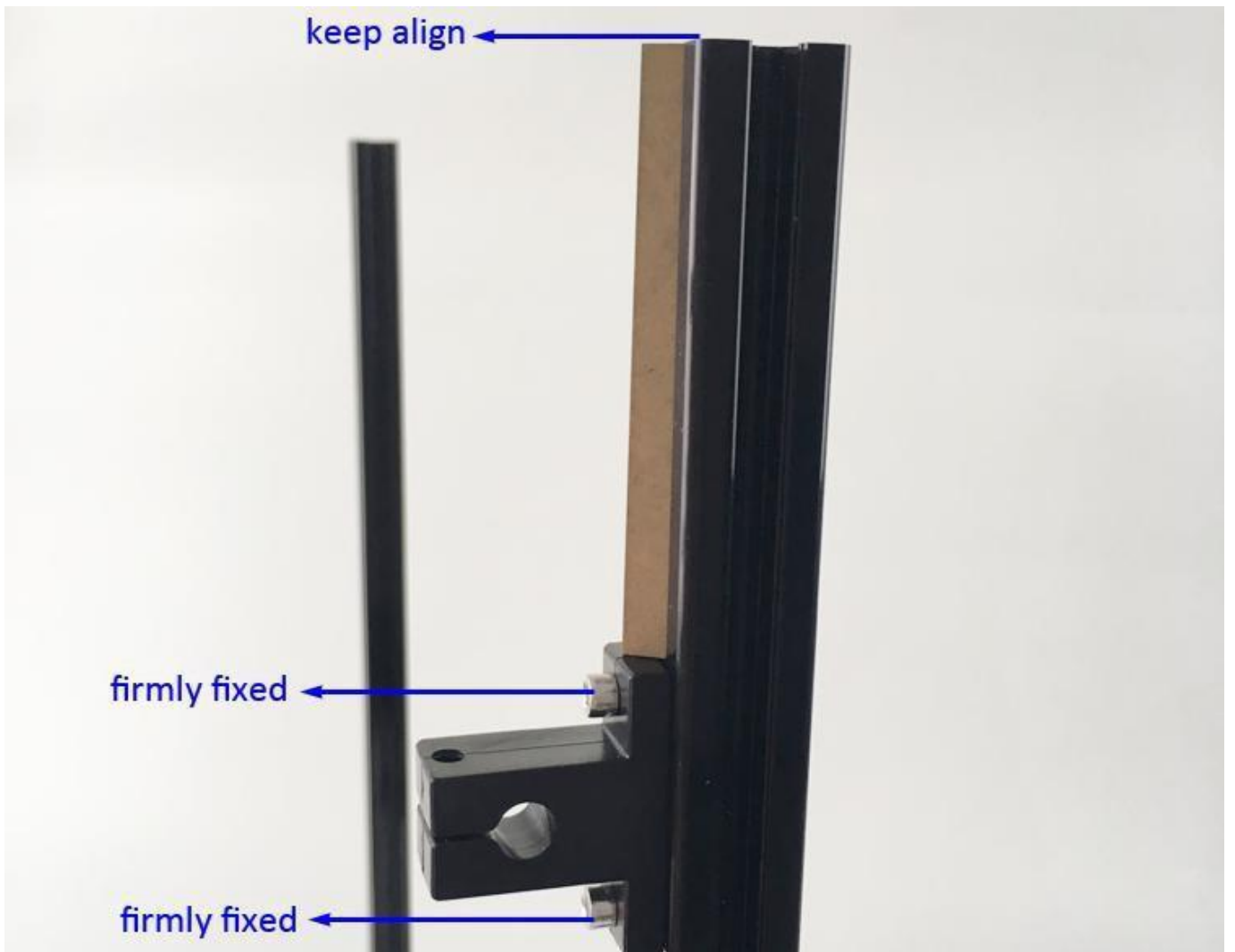
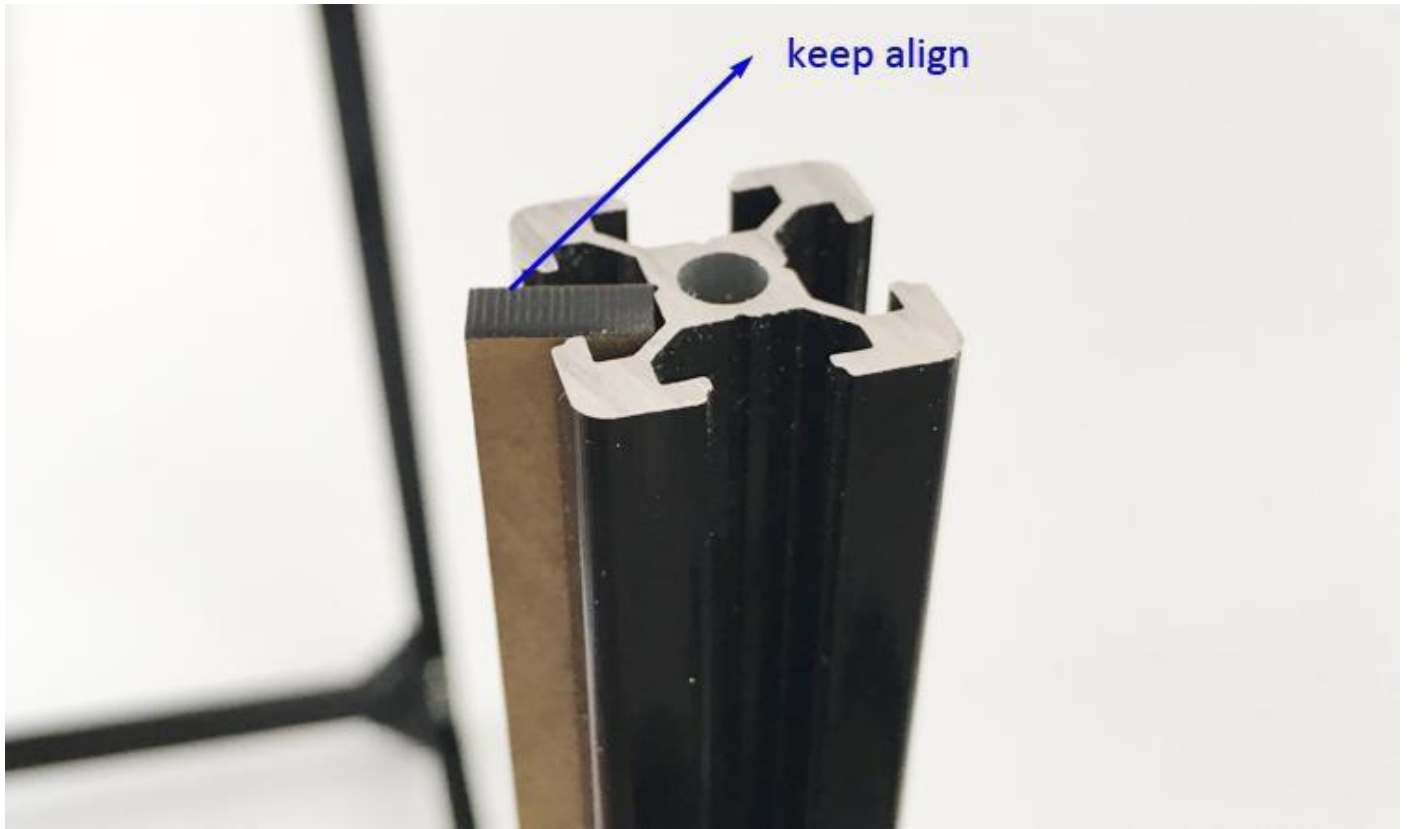





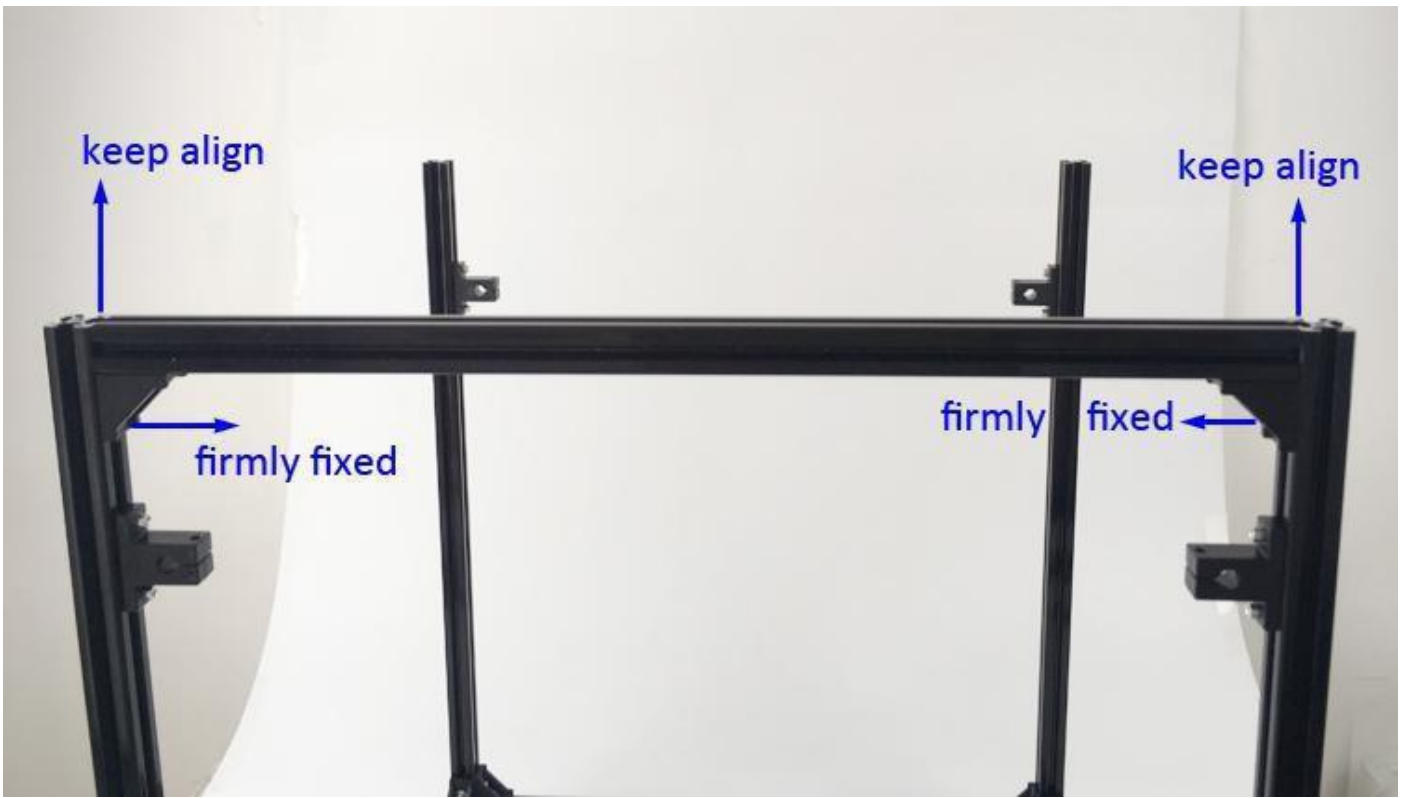



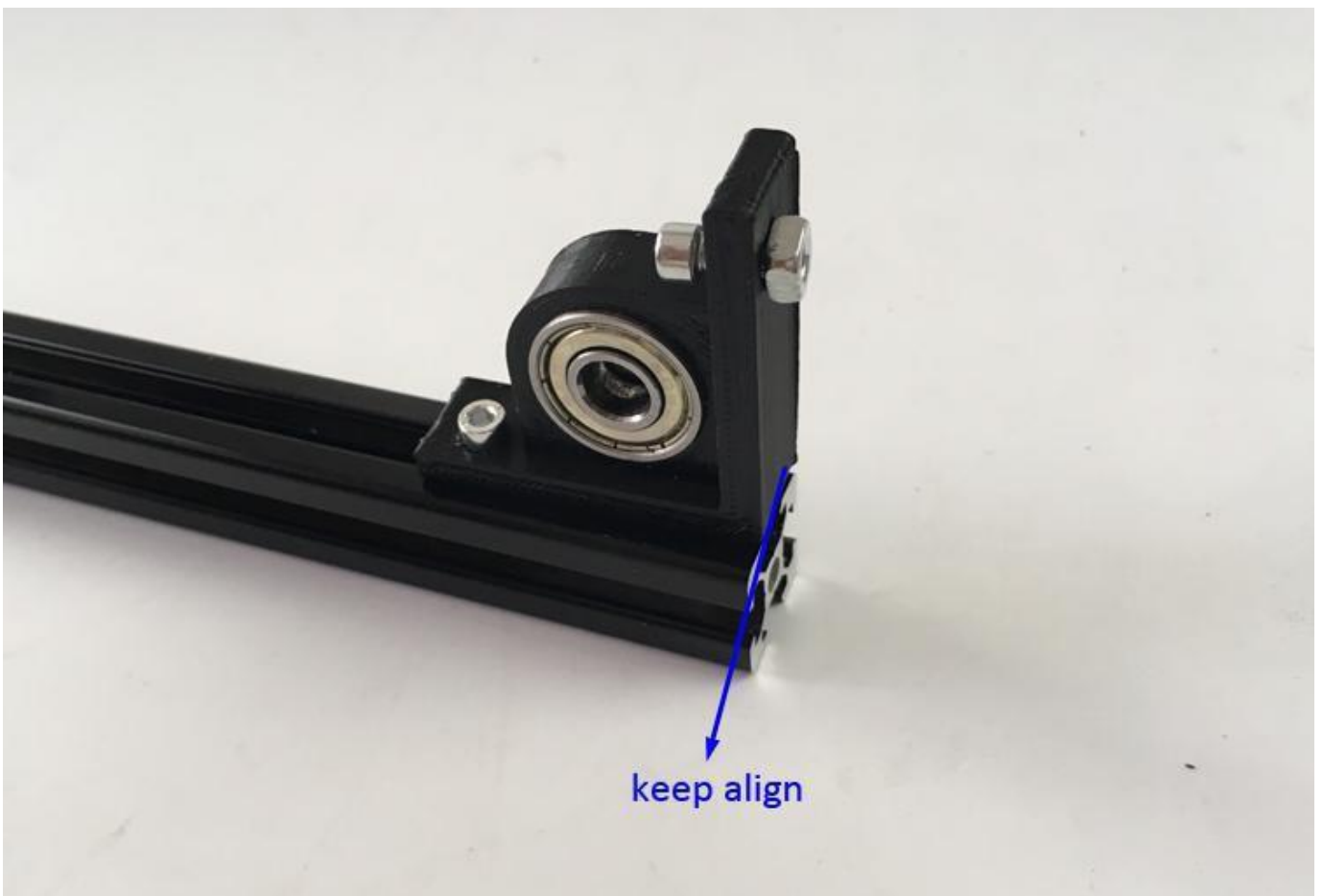
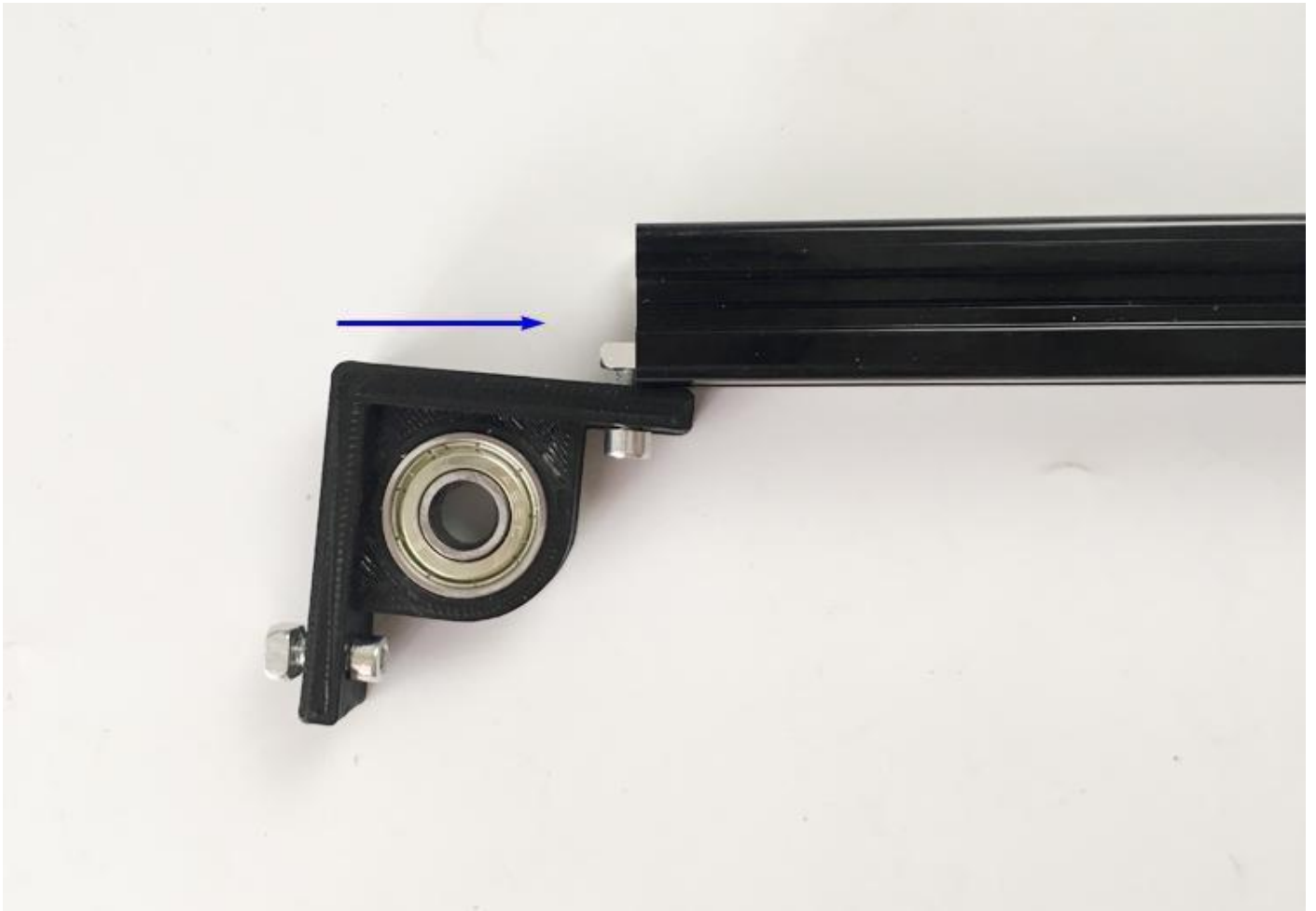





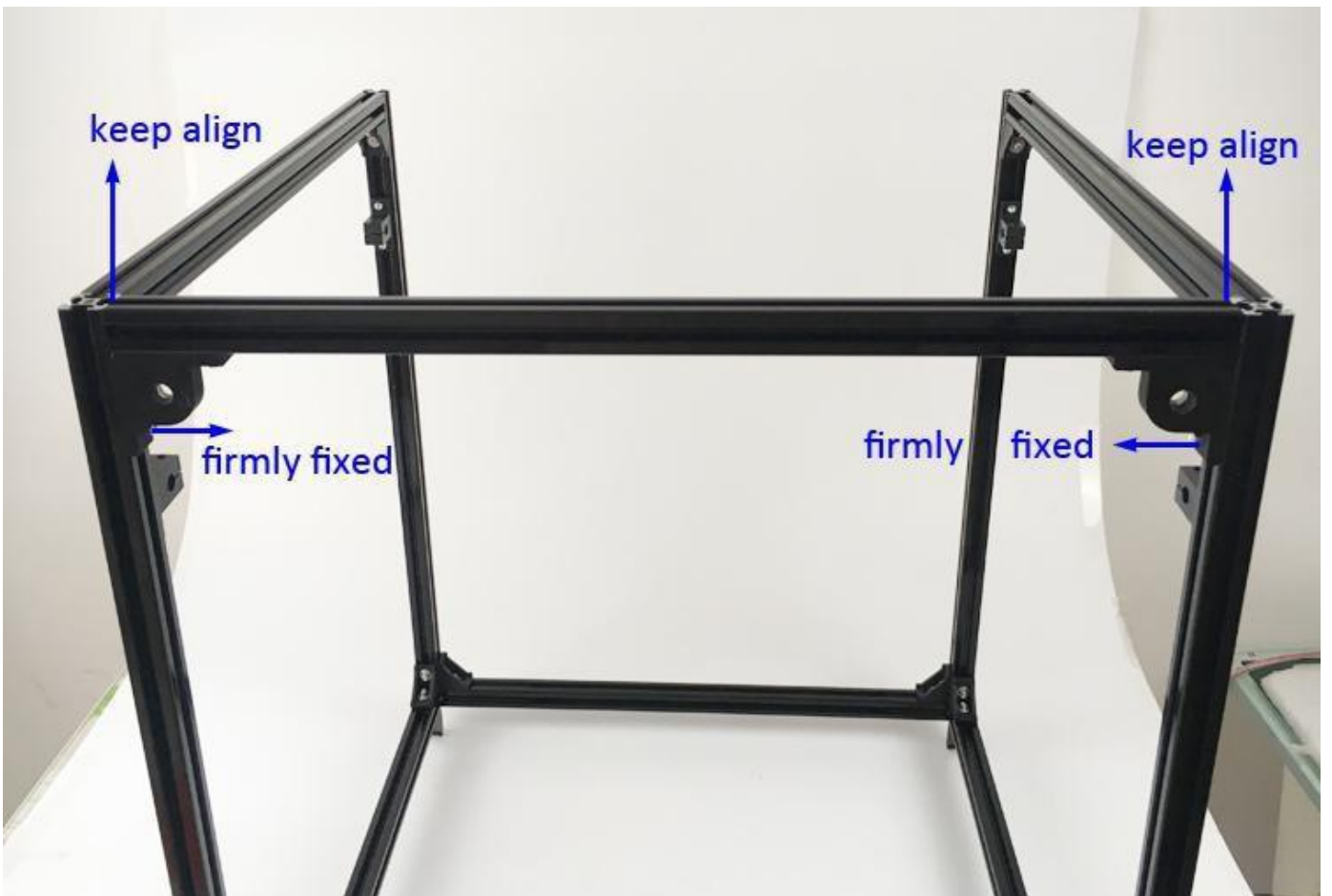



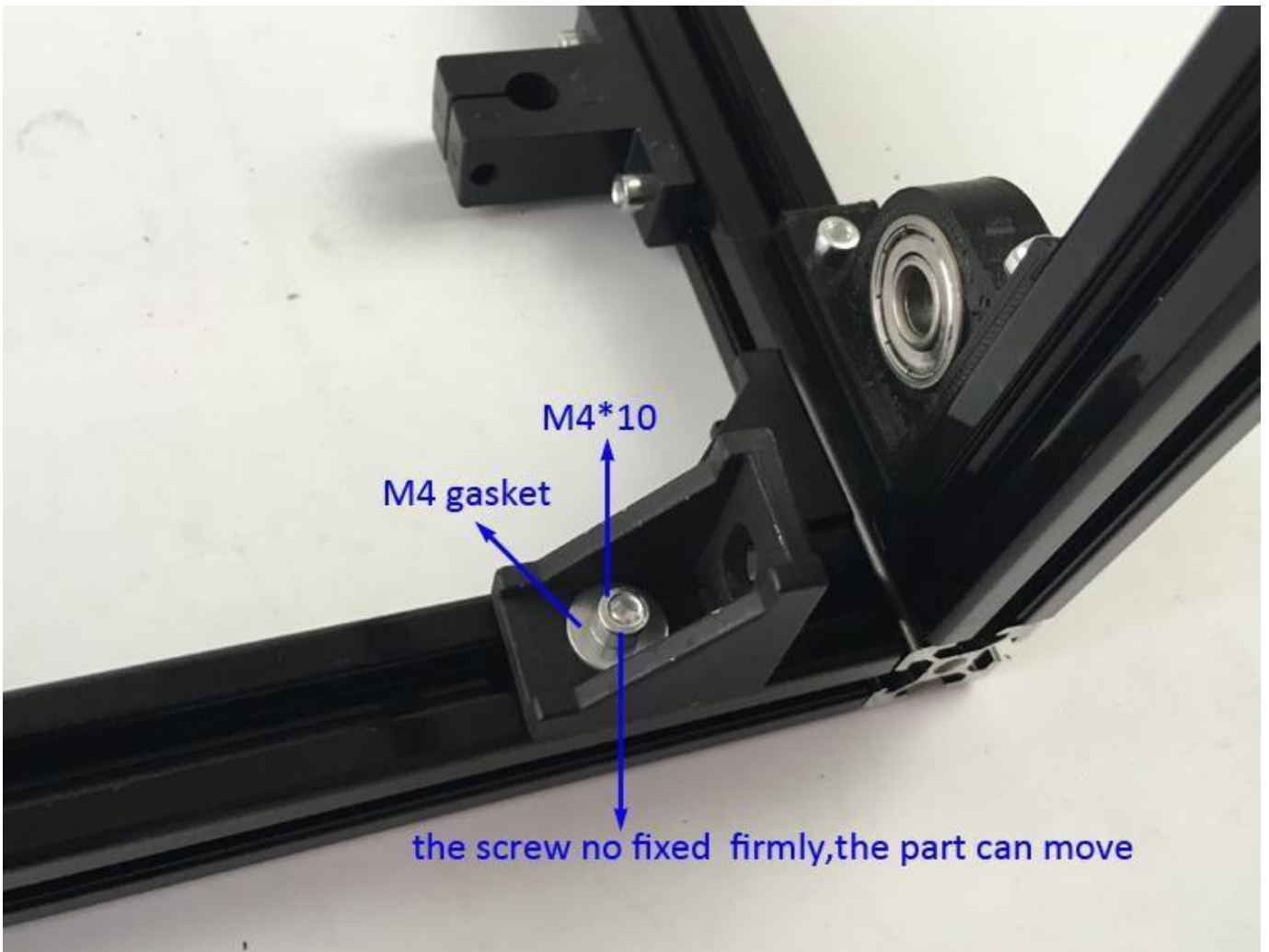
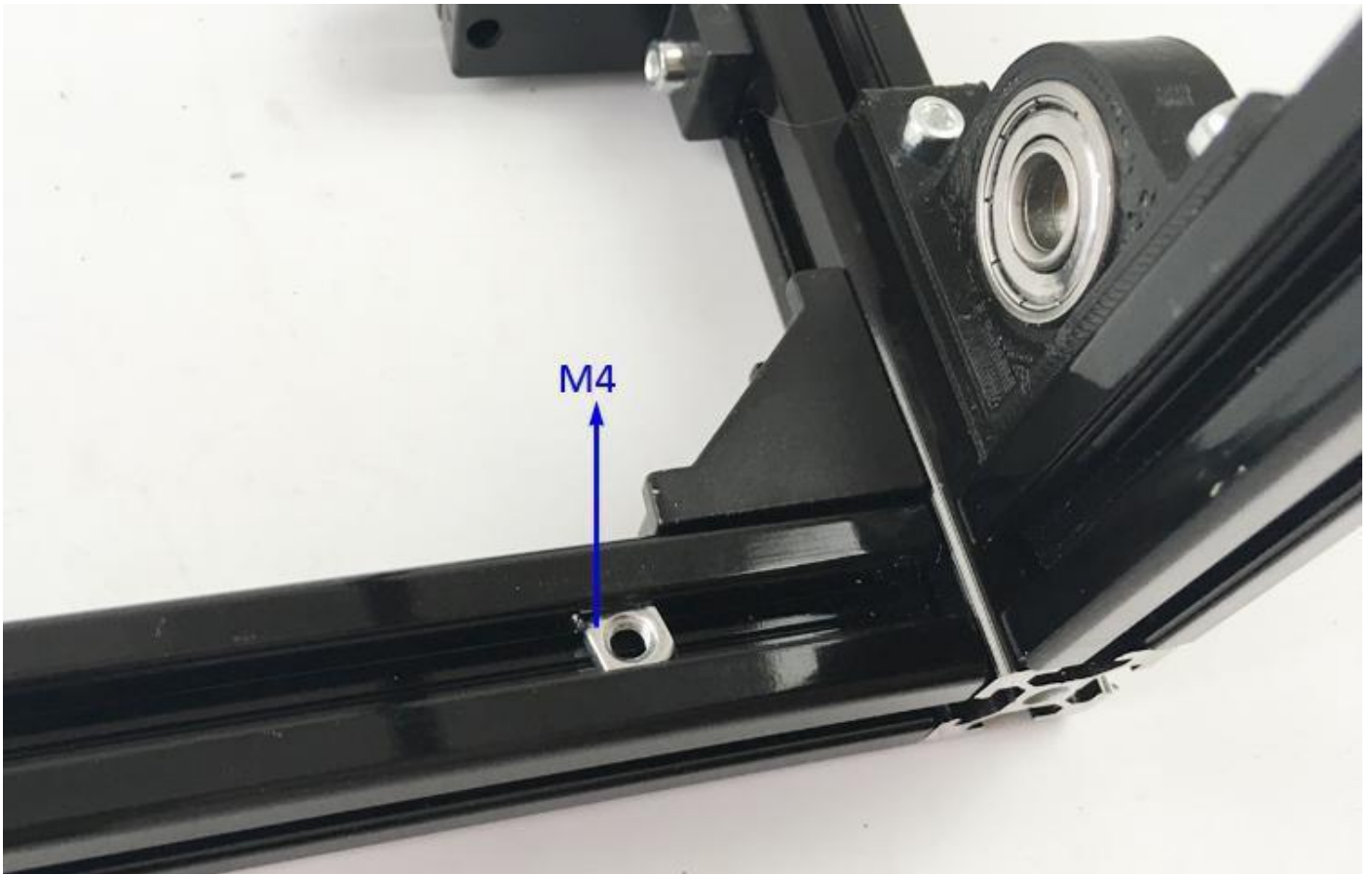

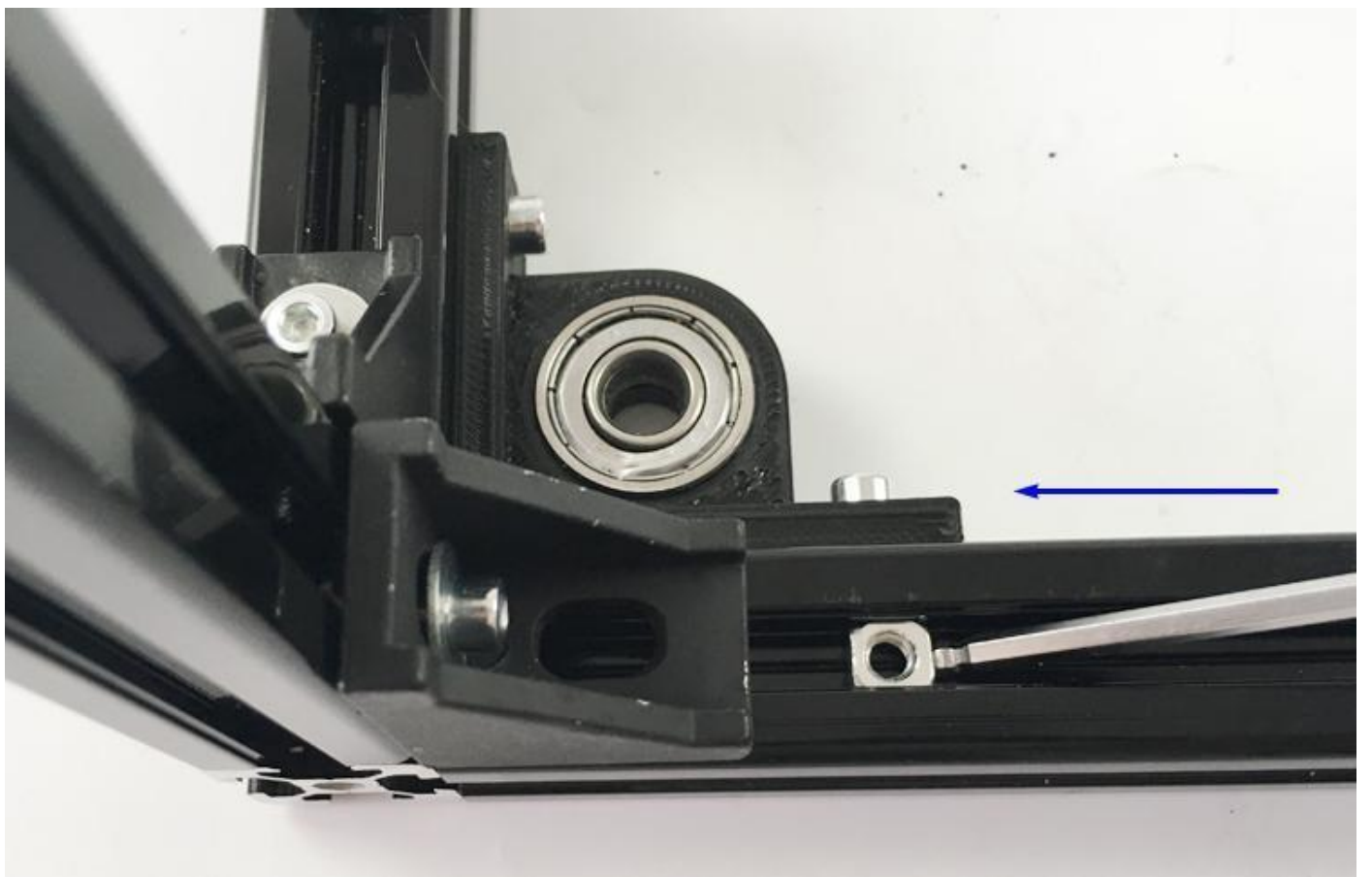
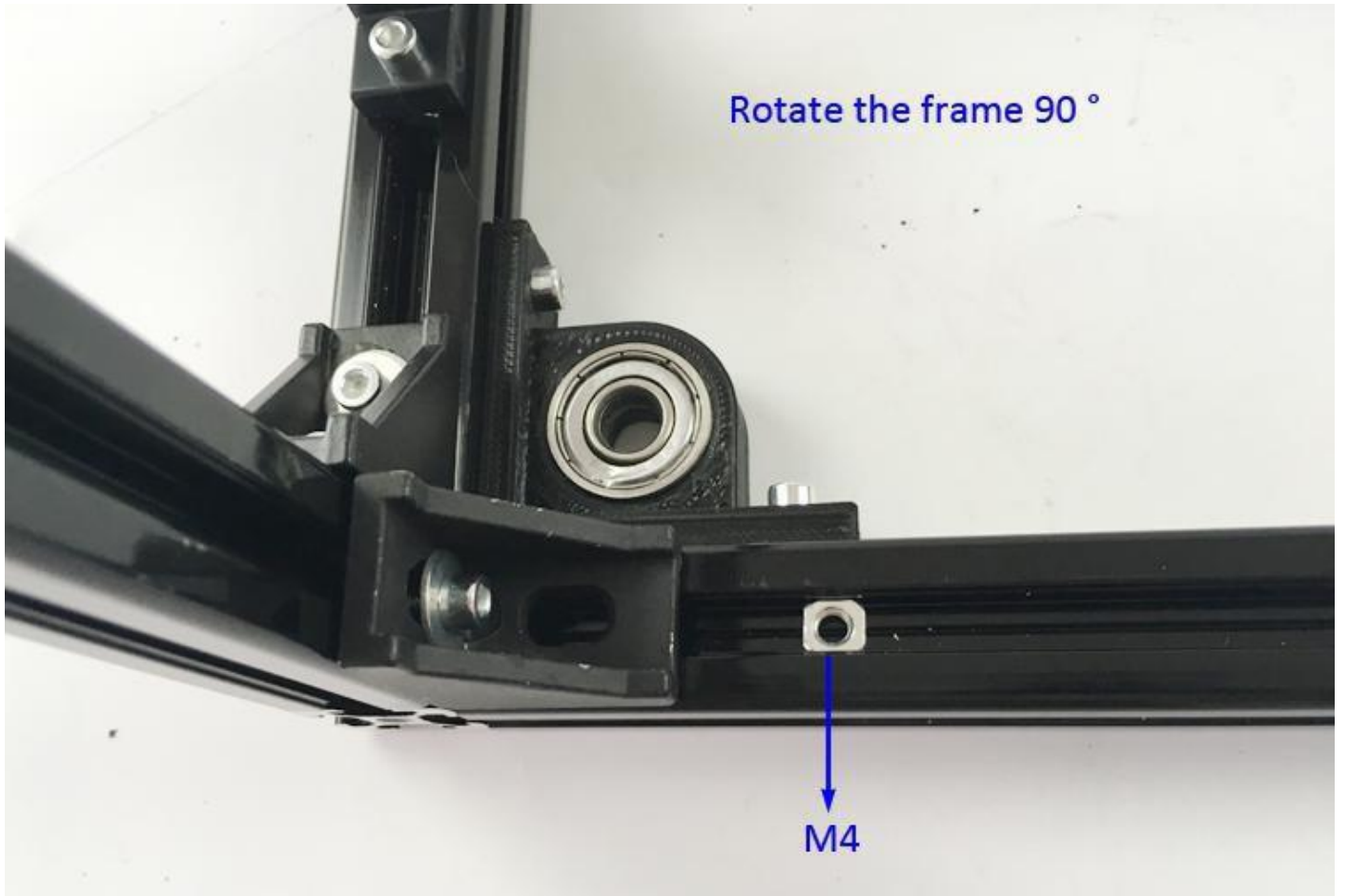

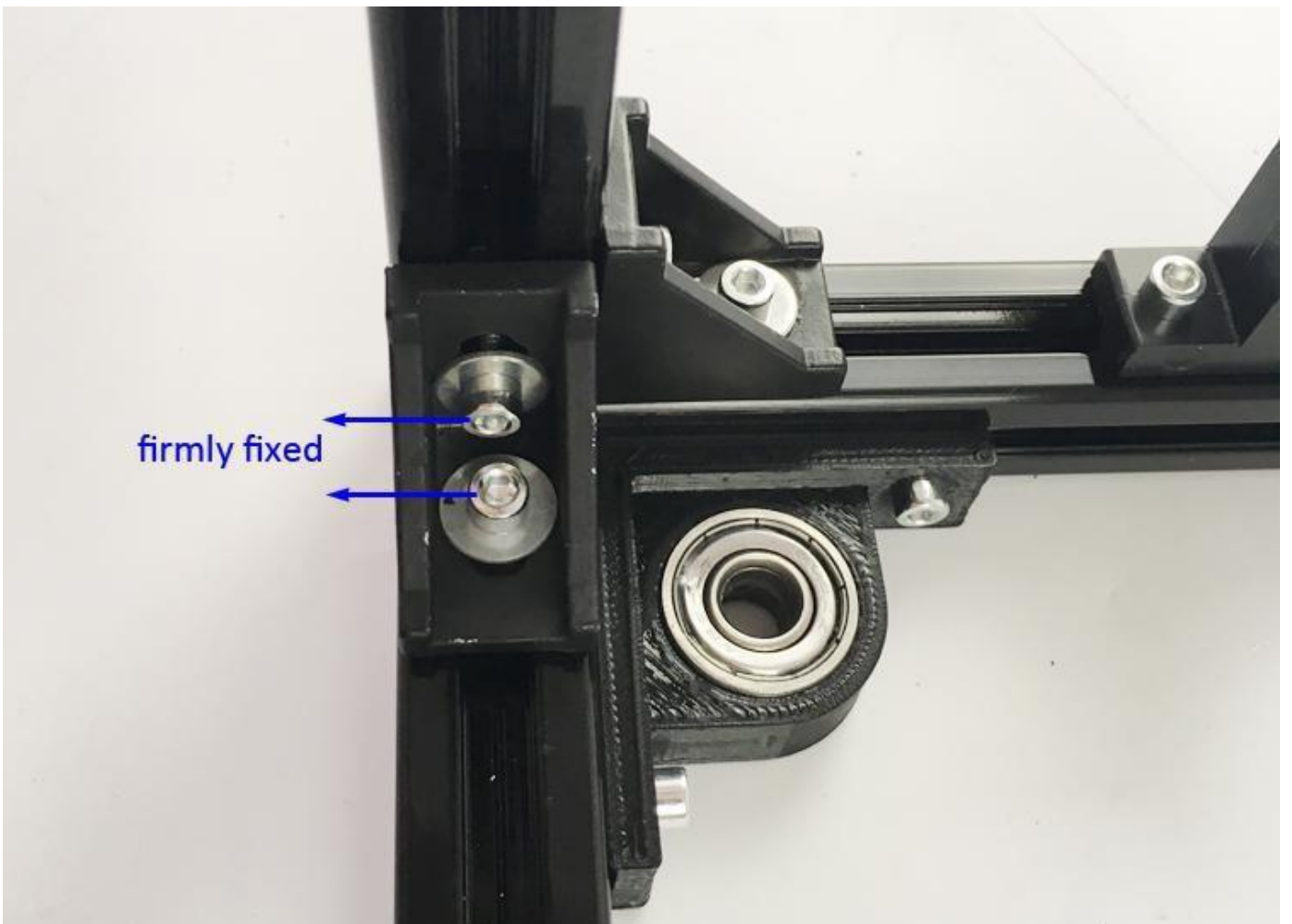
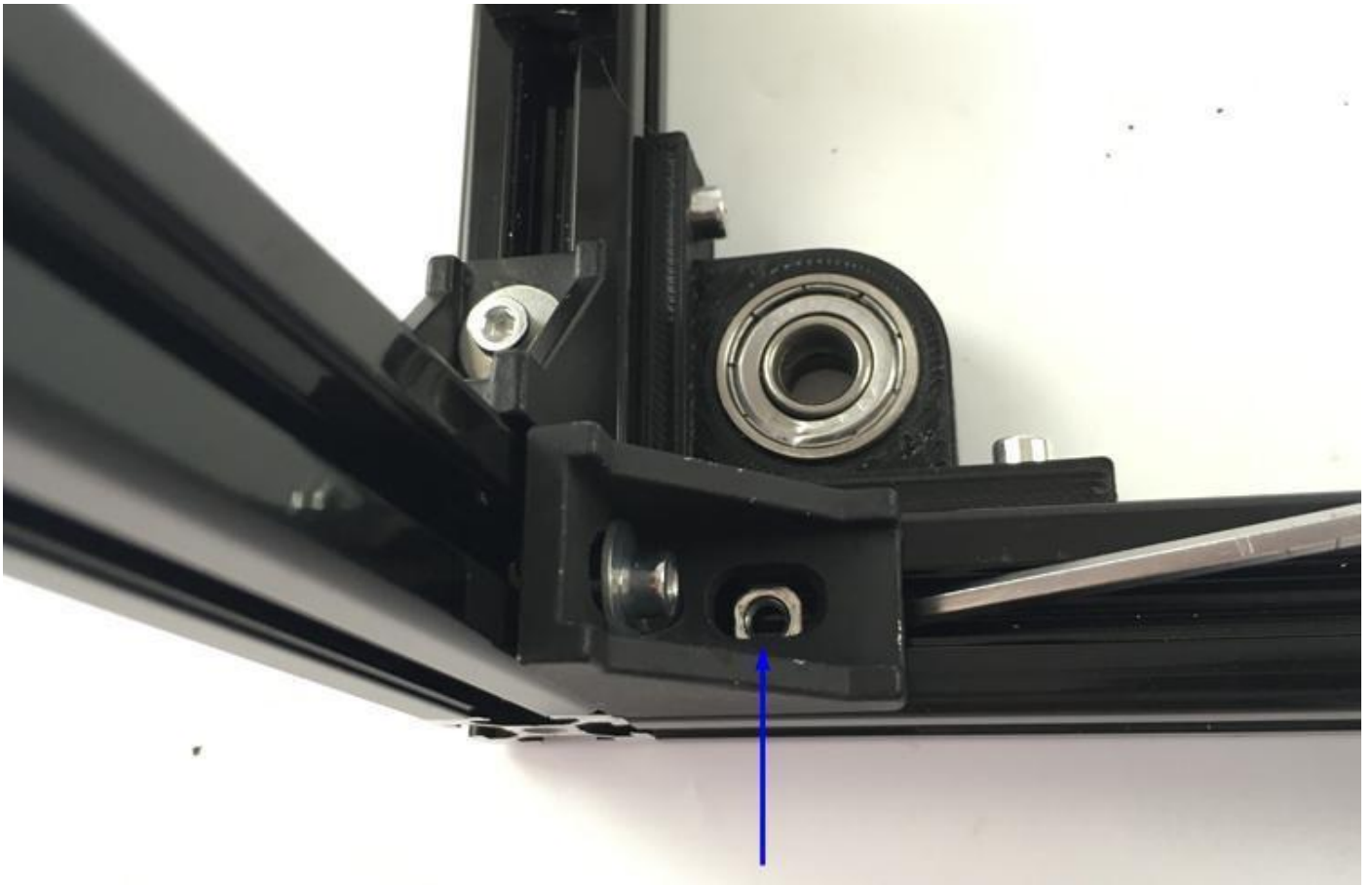

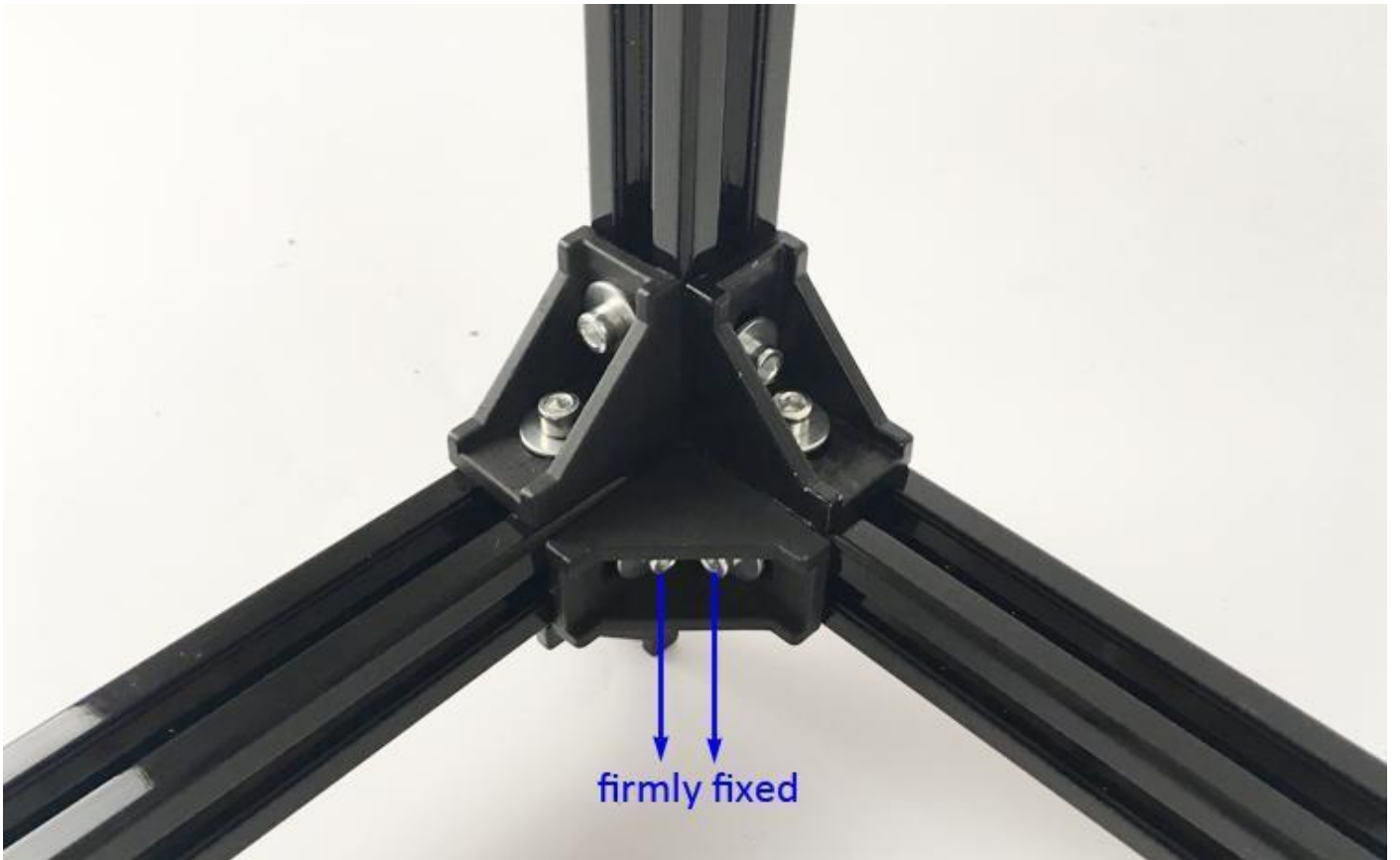



## 2 Assembly X axis and Y axis

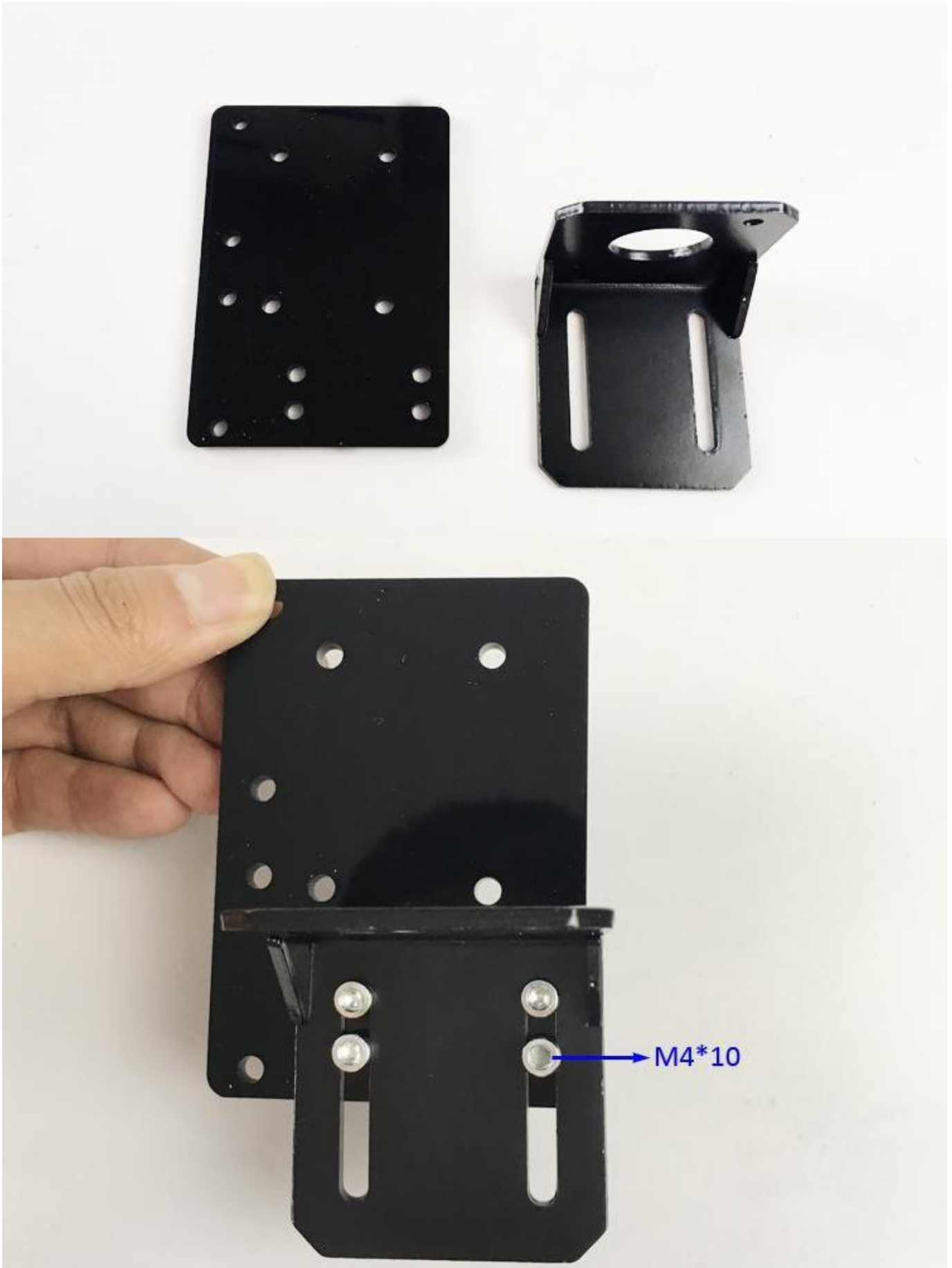



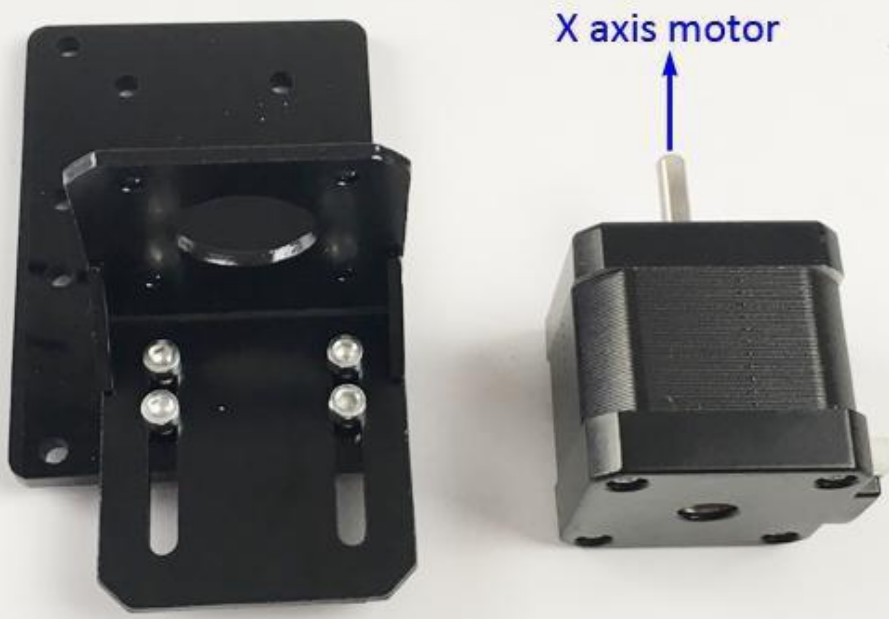
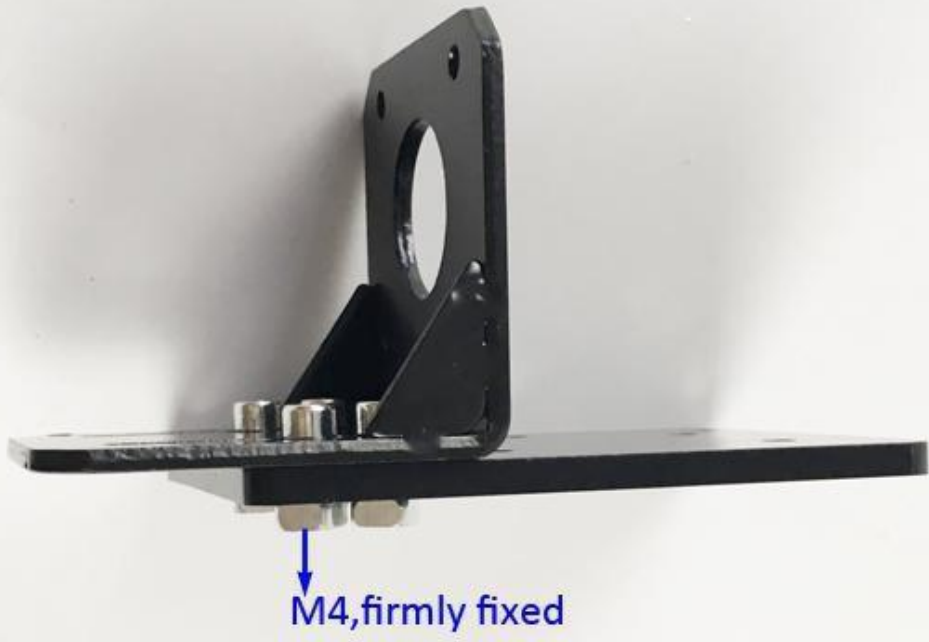

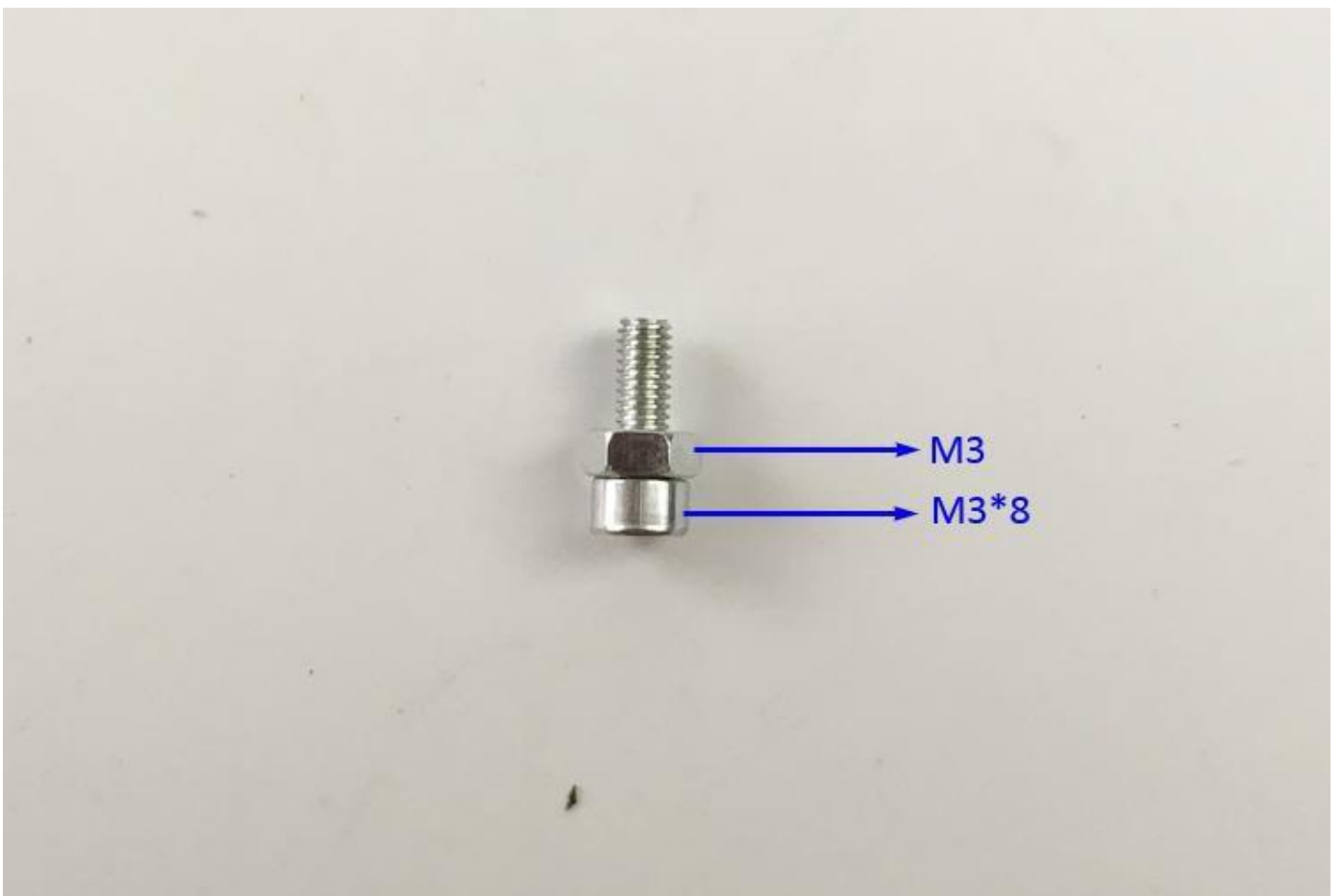
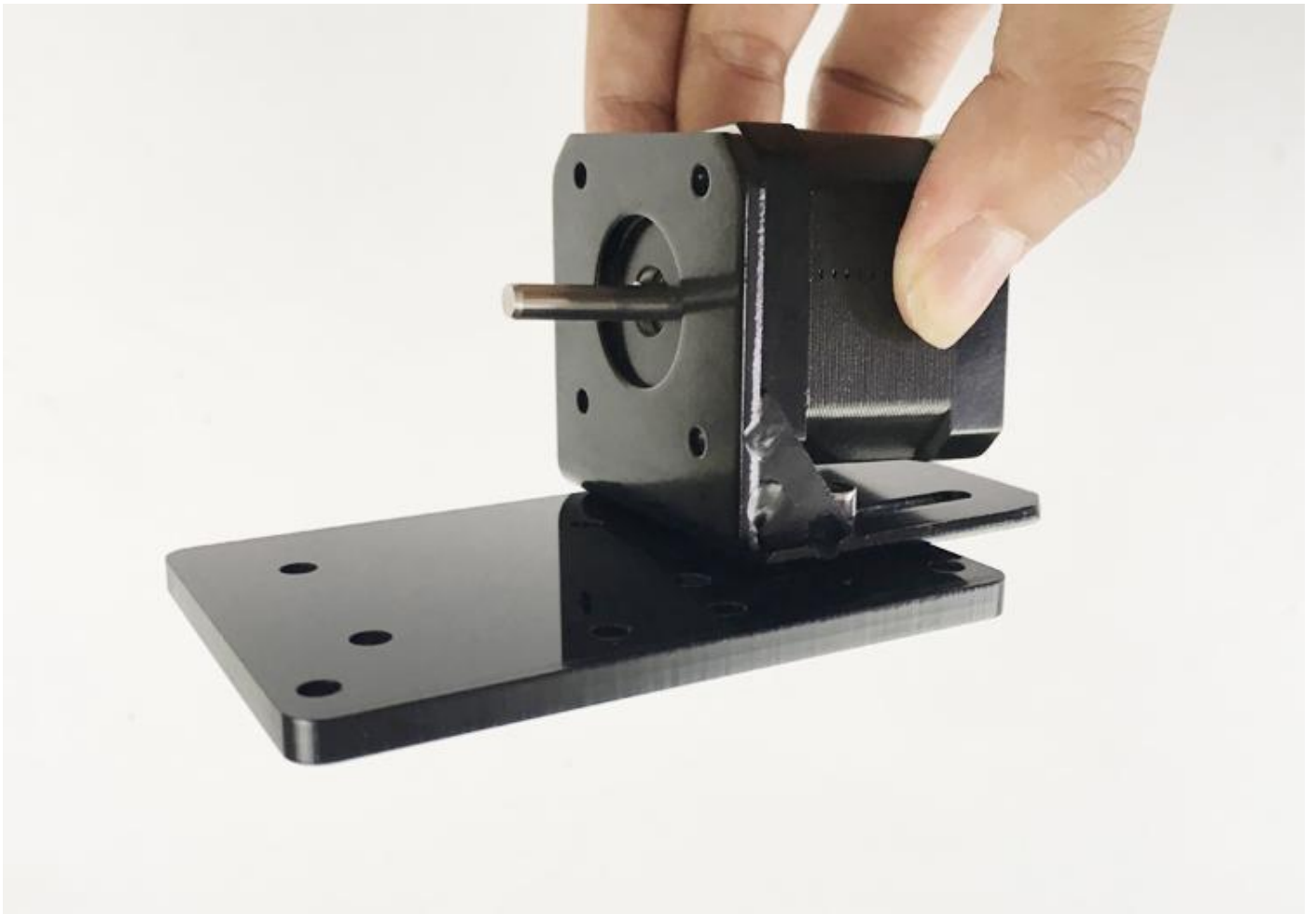

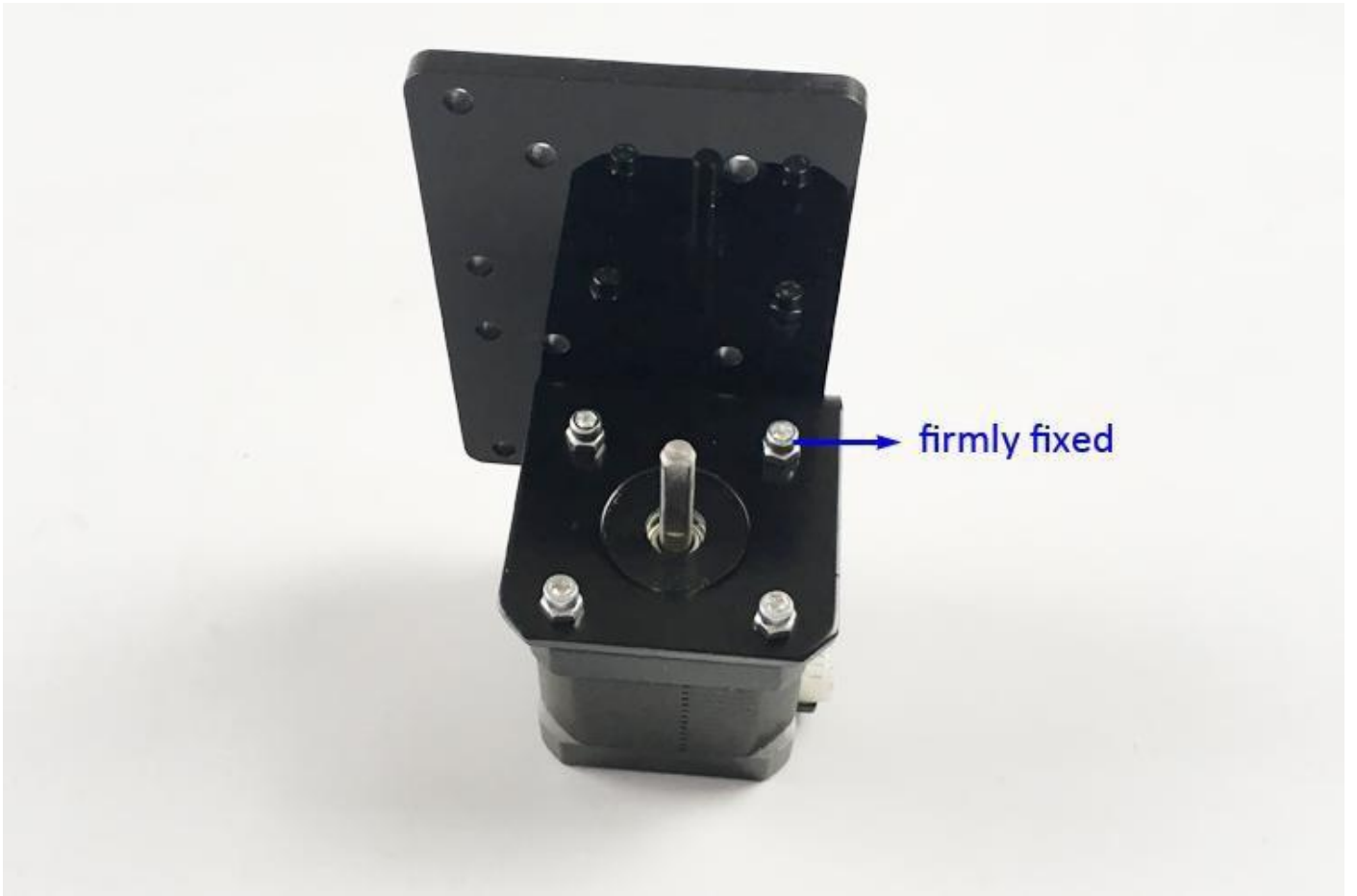



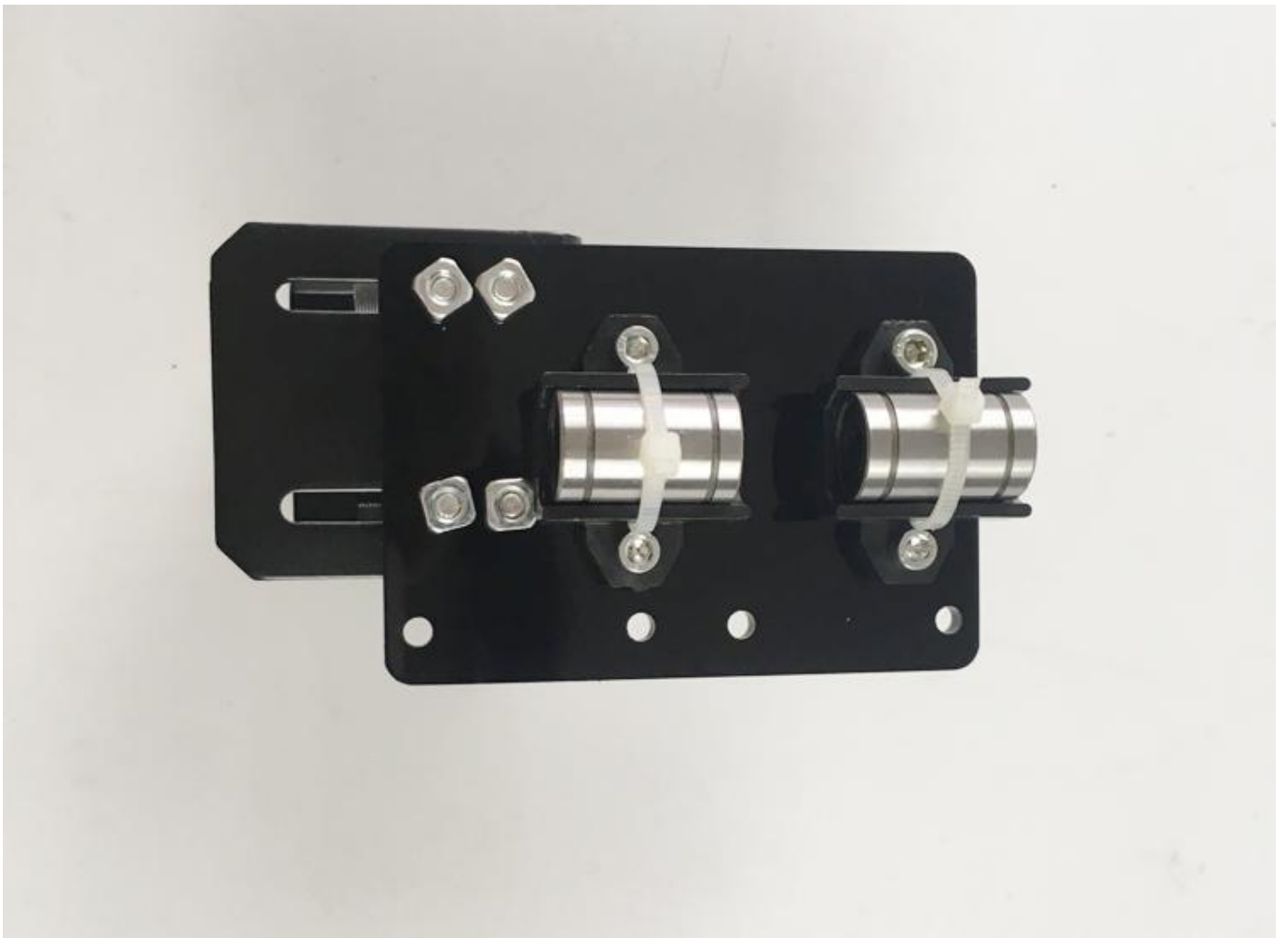
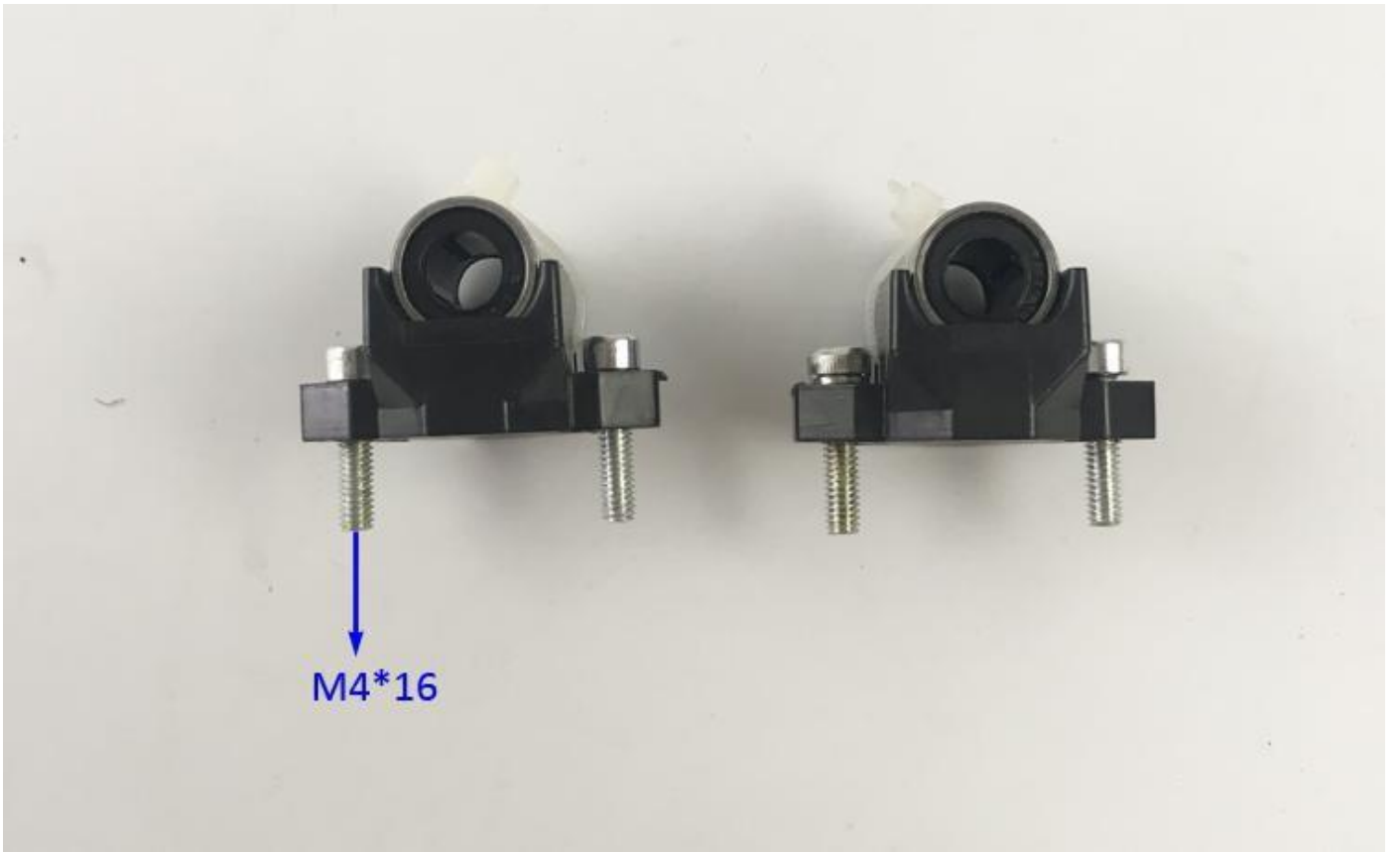

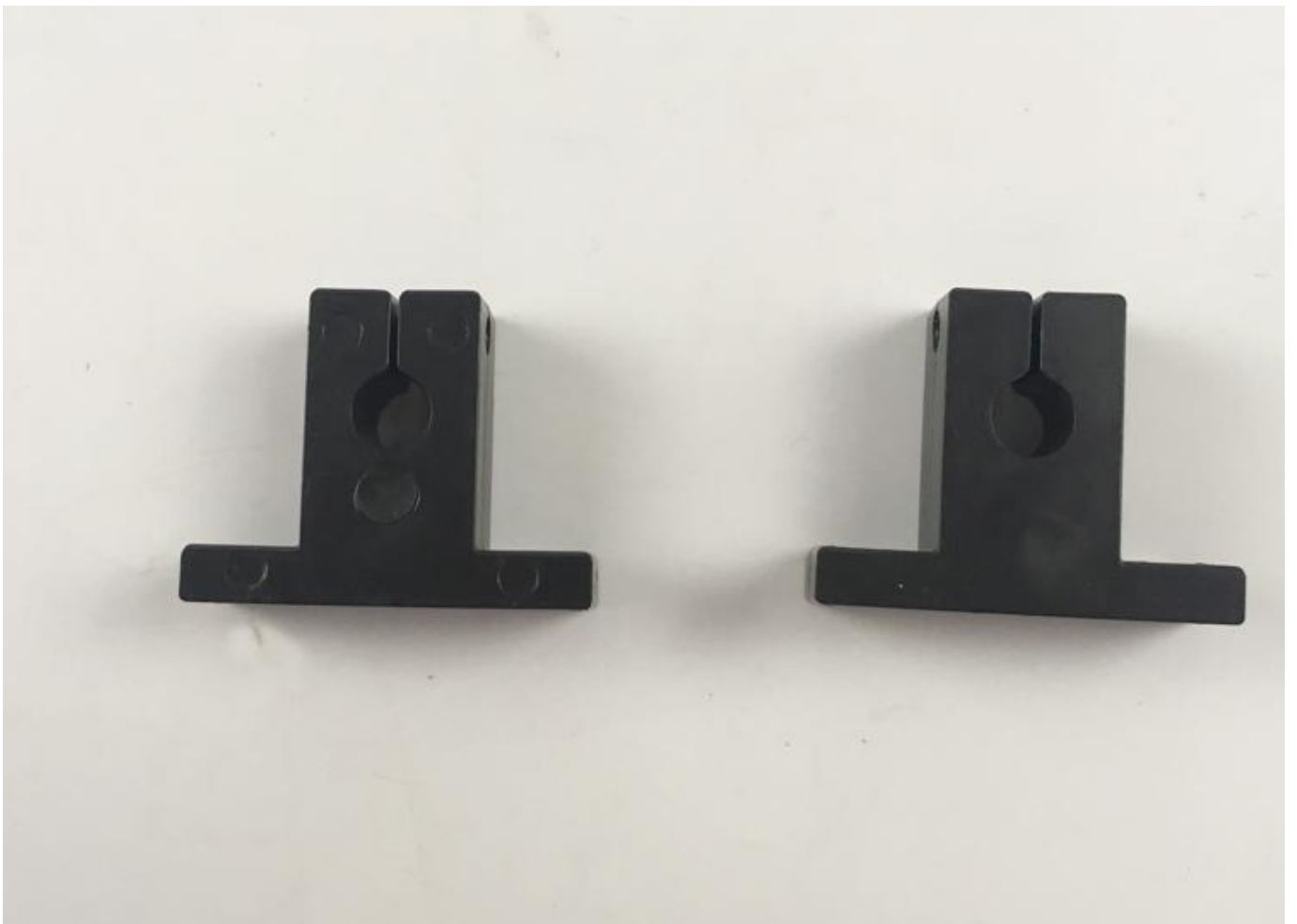
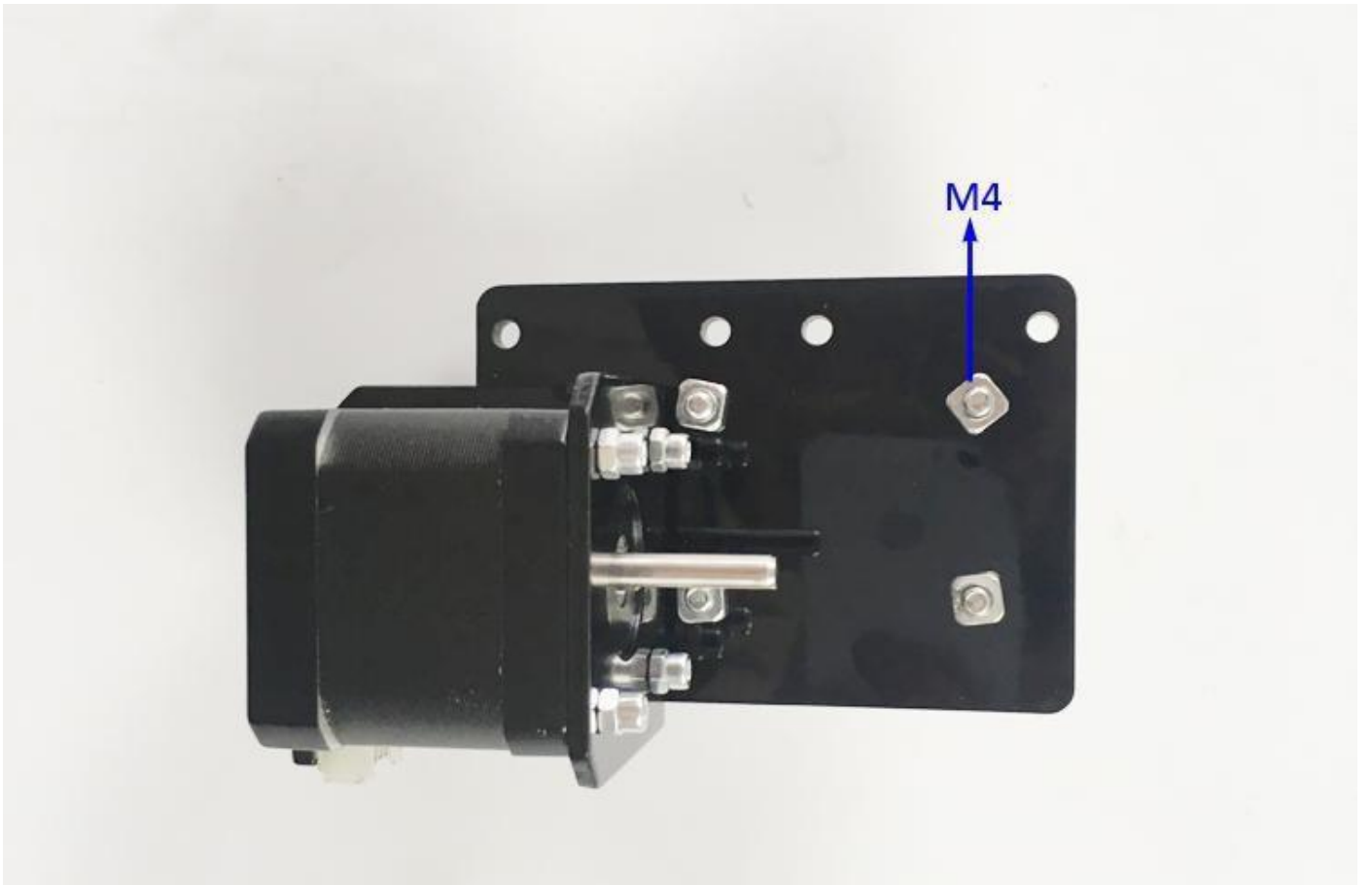

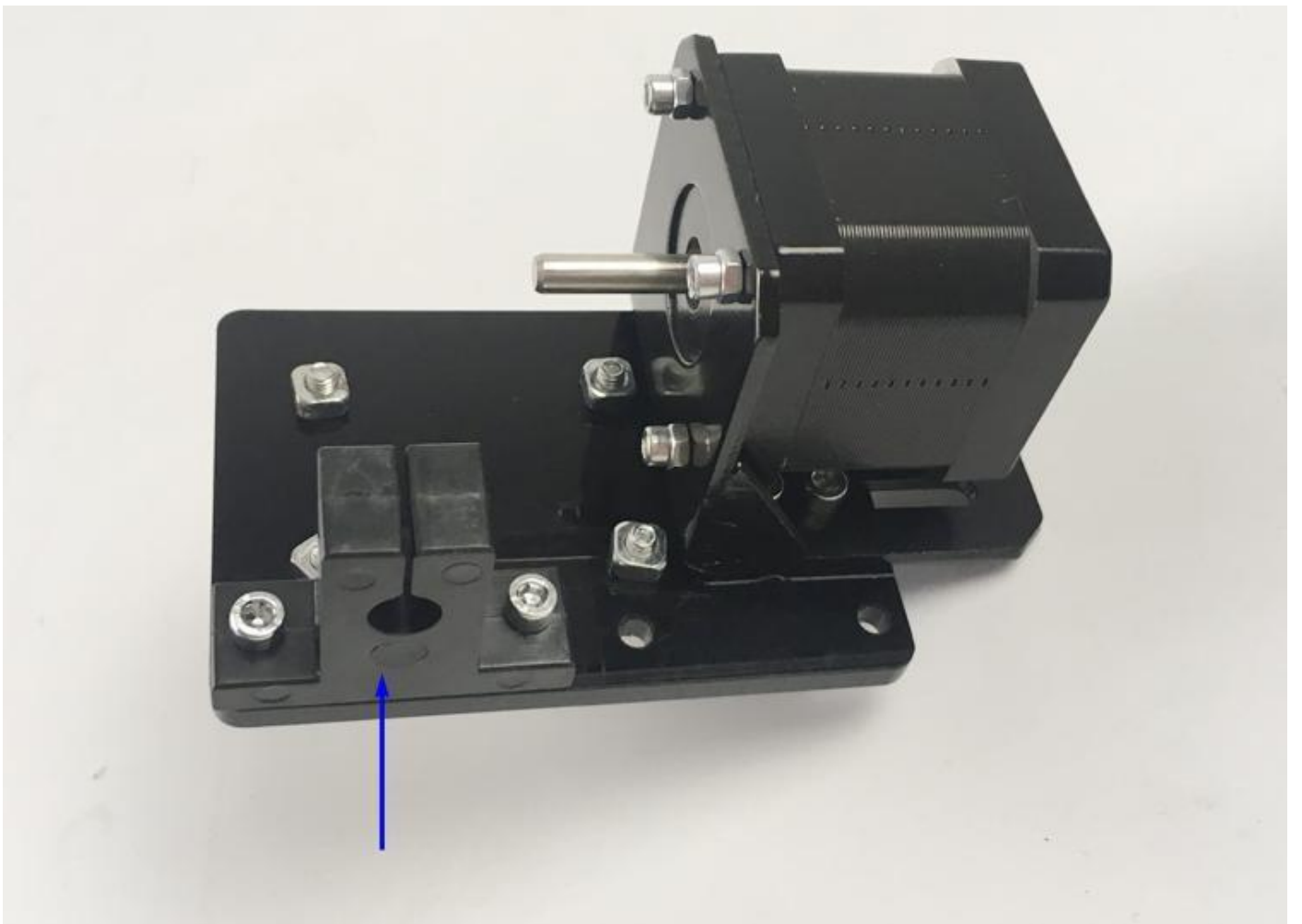
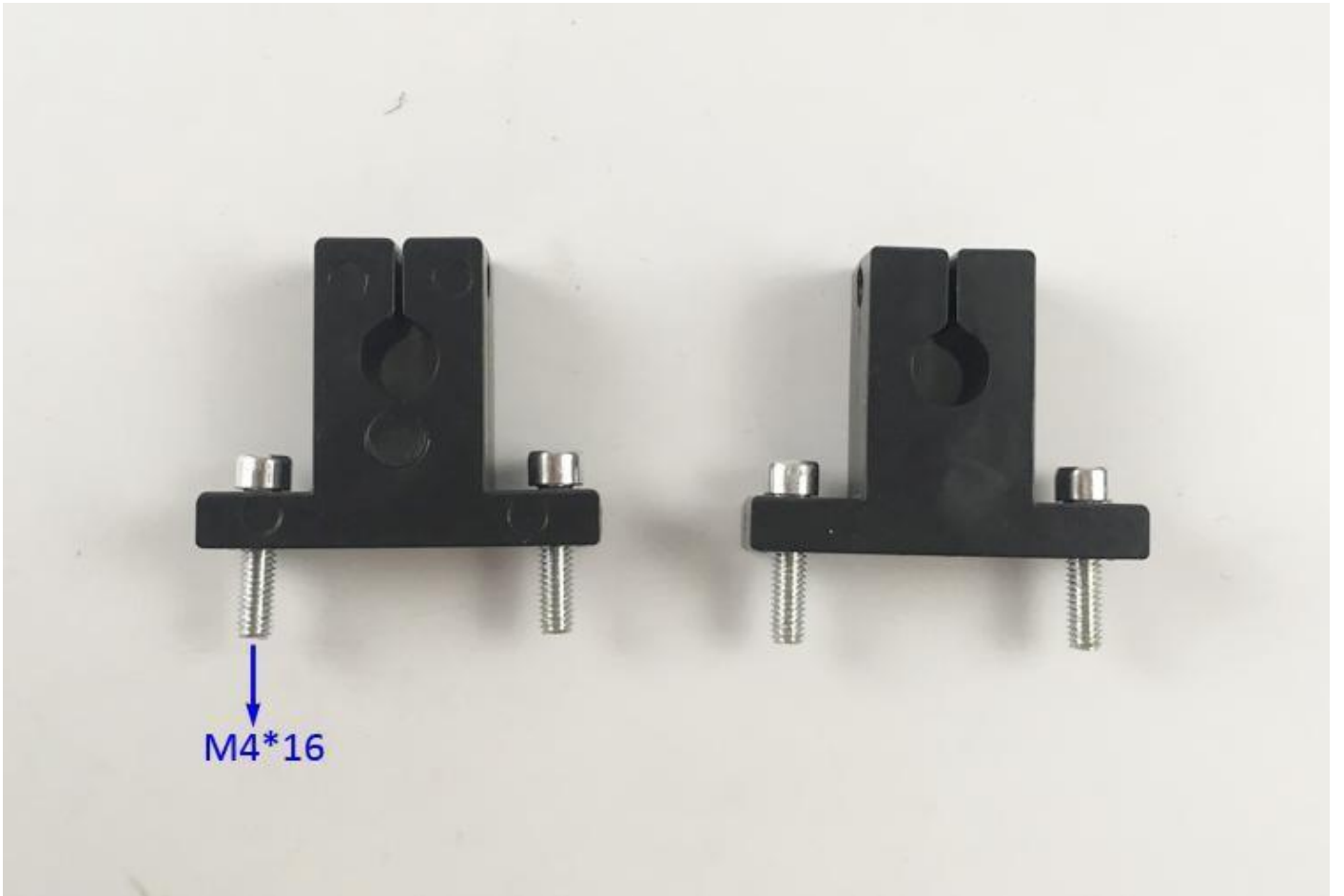

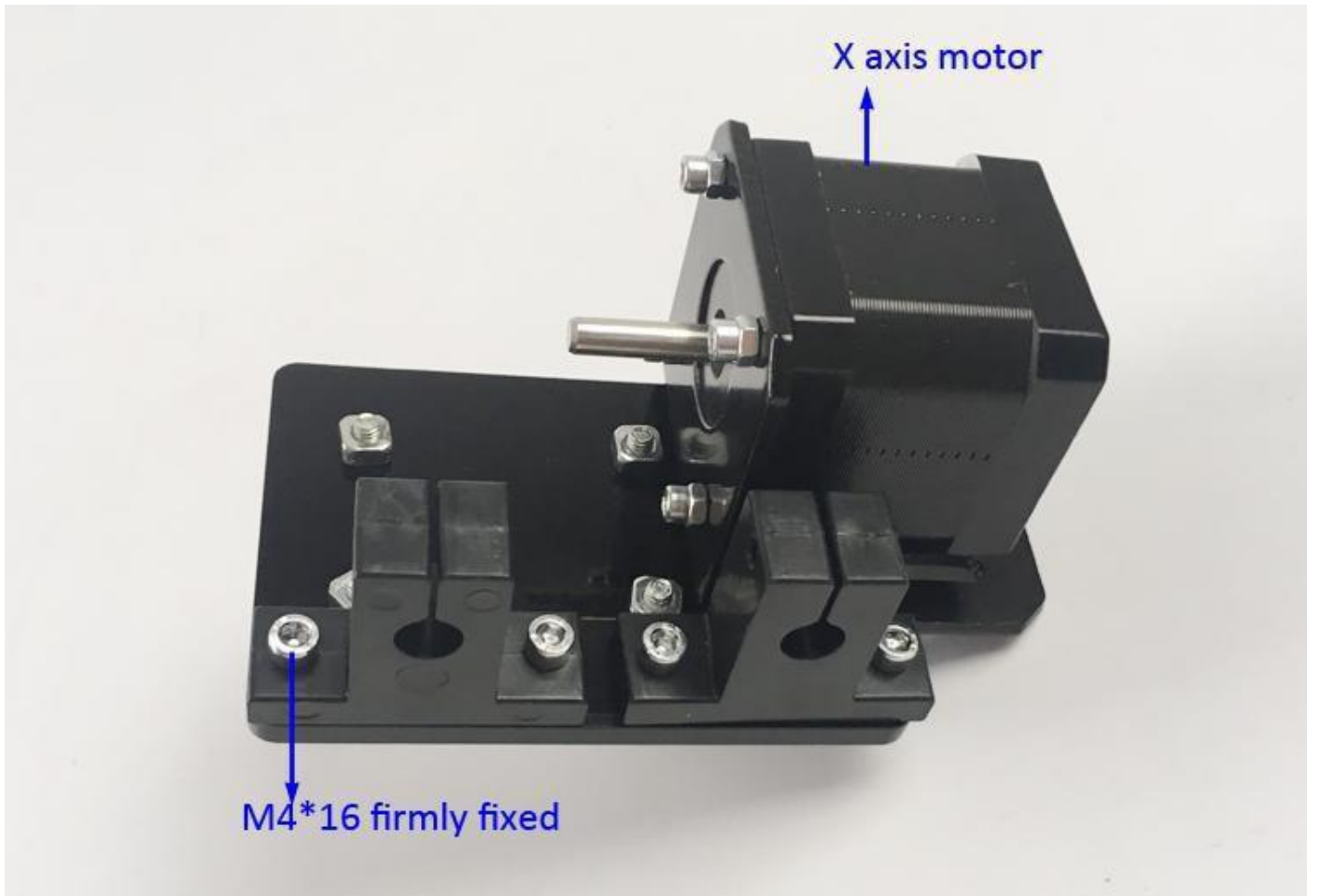







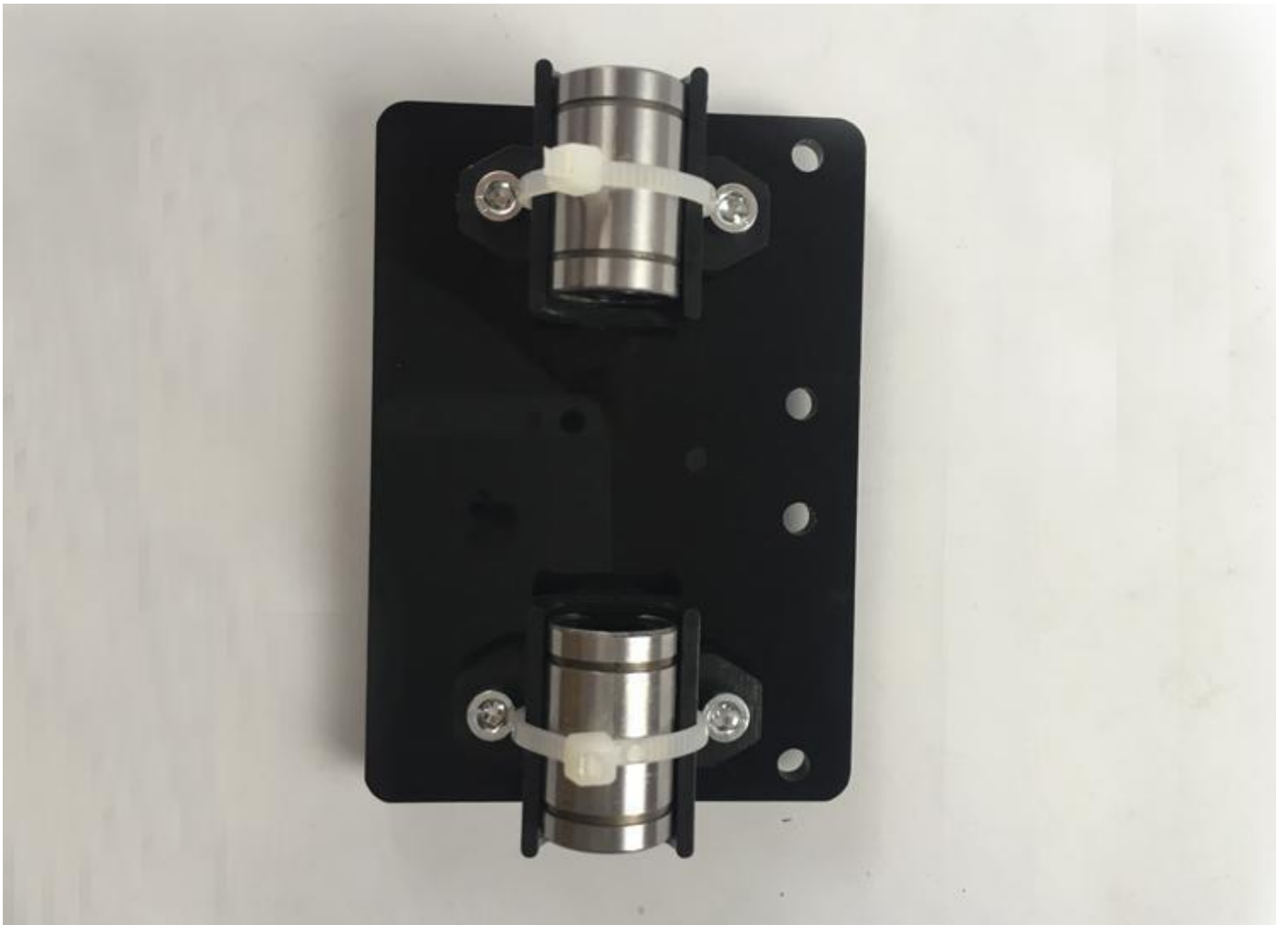

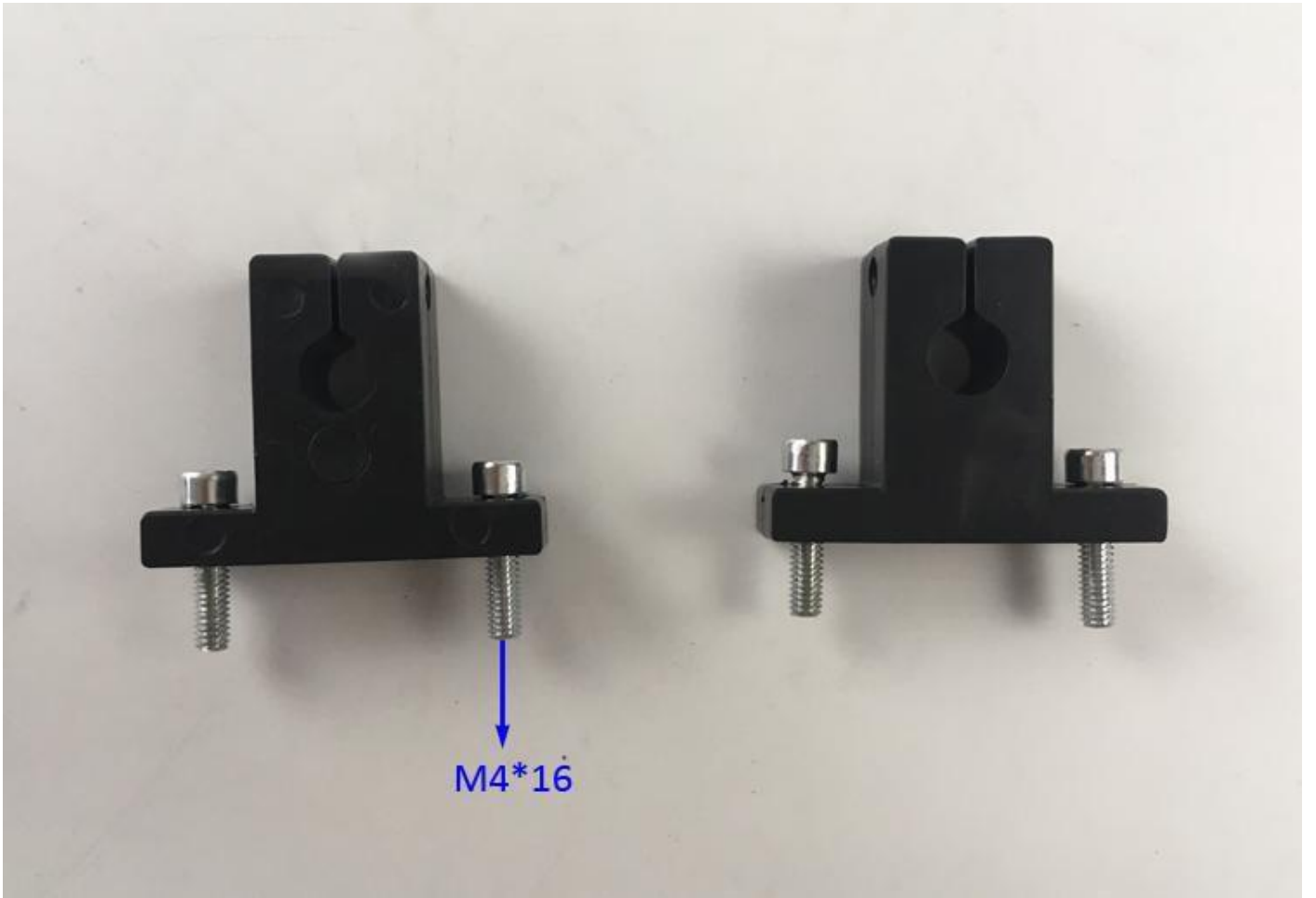



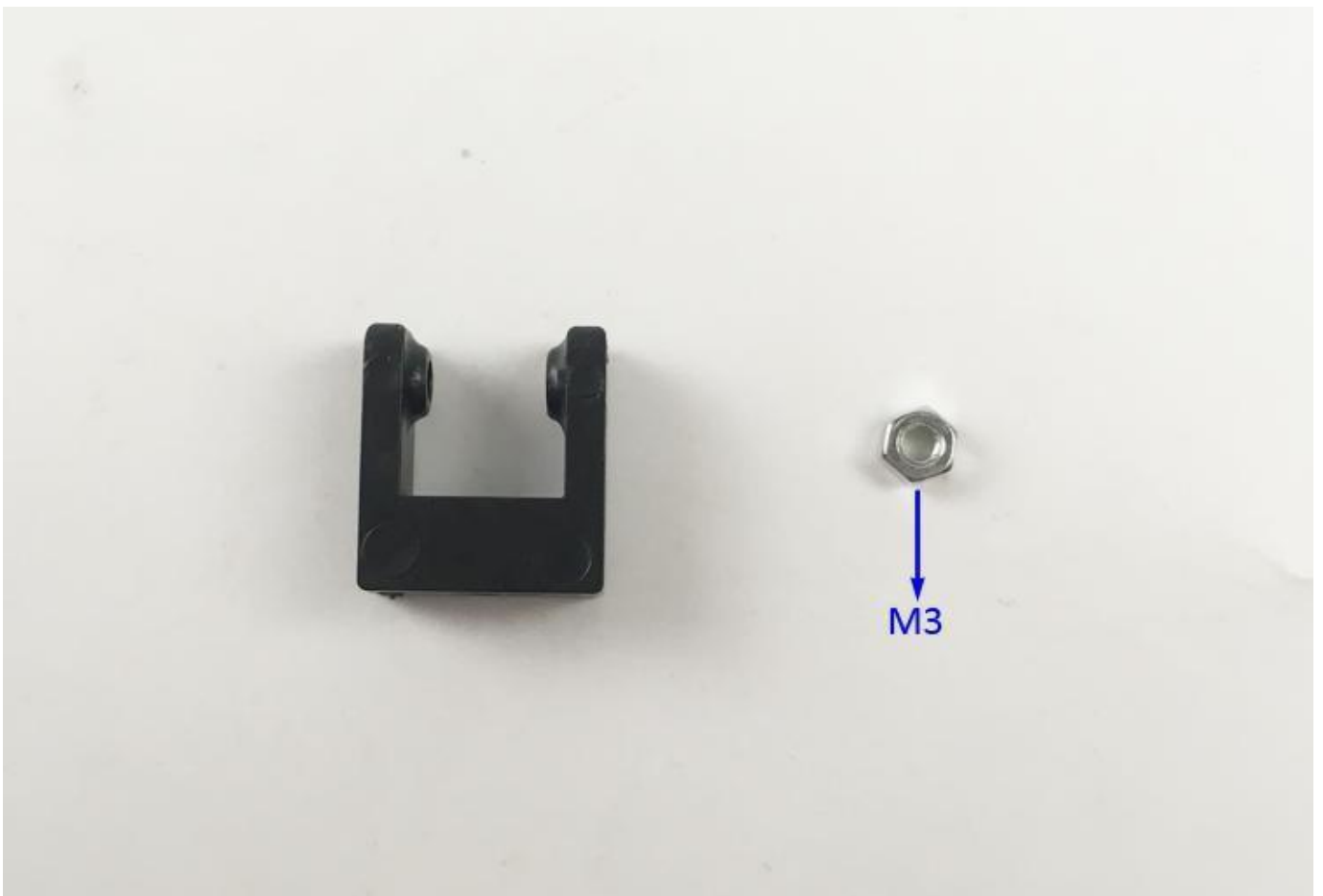
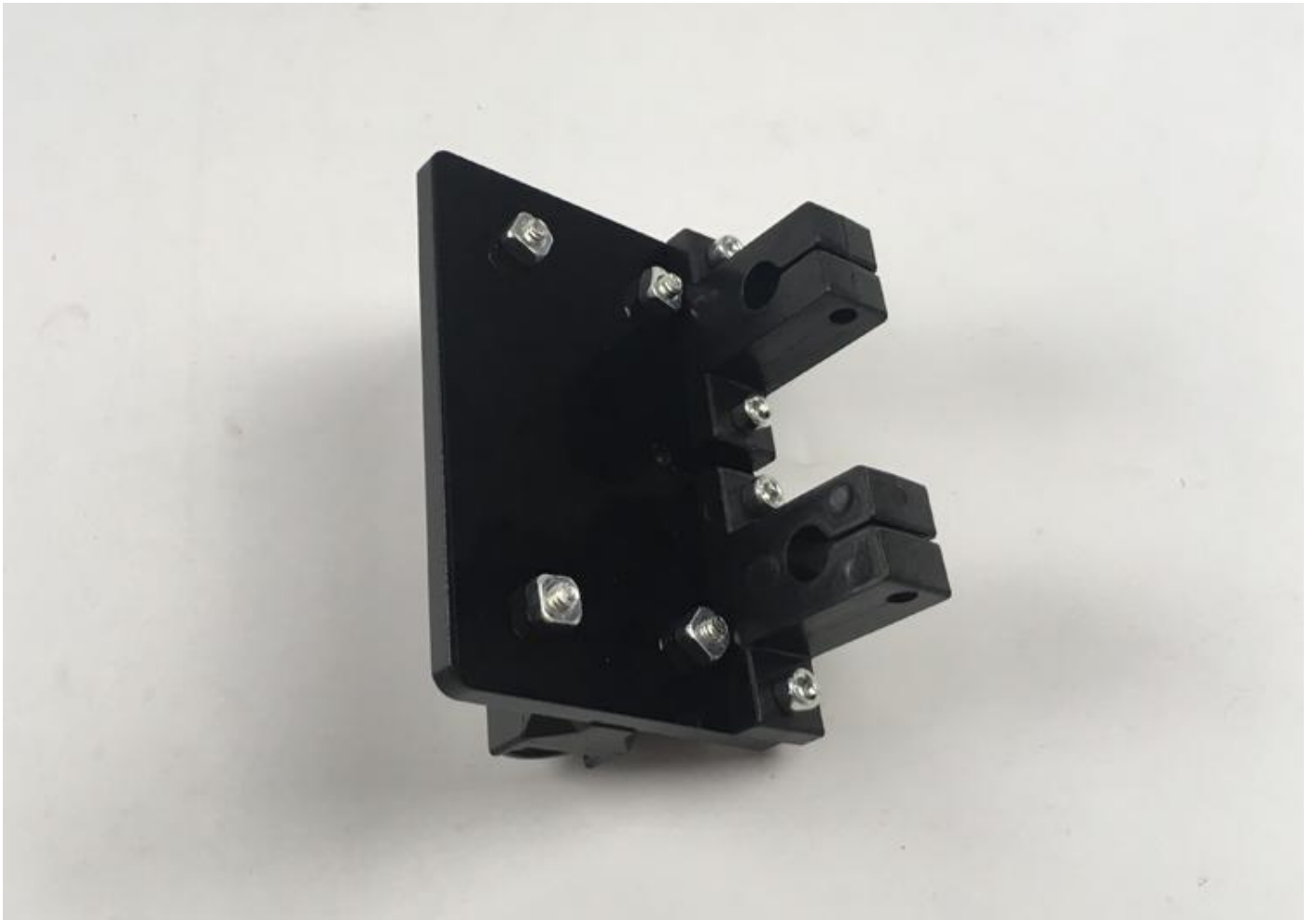

caught the M3 screw hole into in by plier



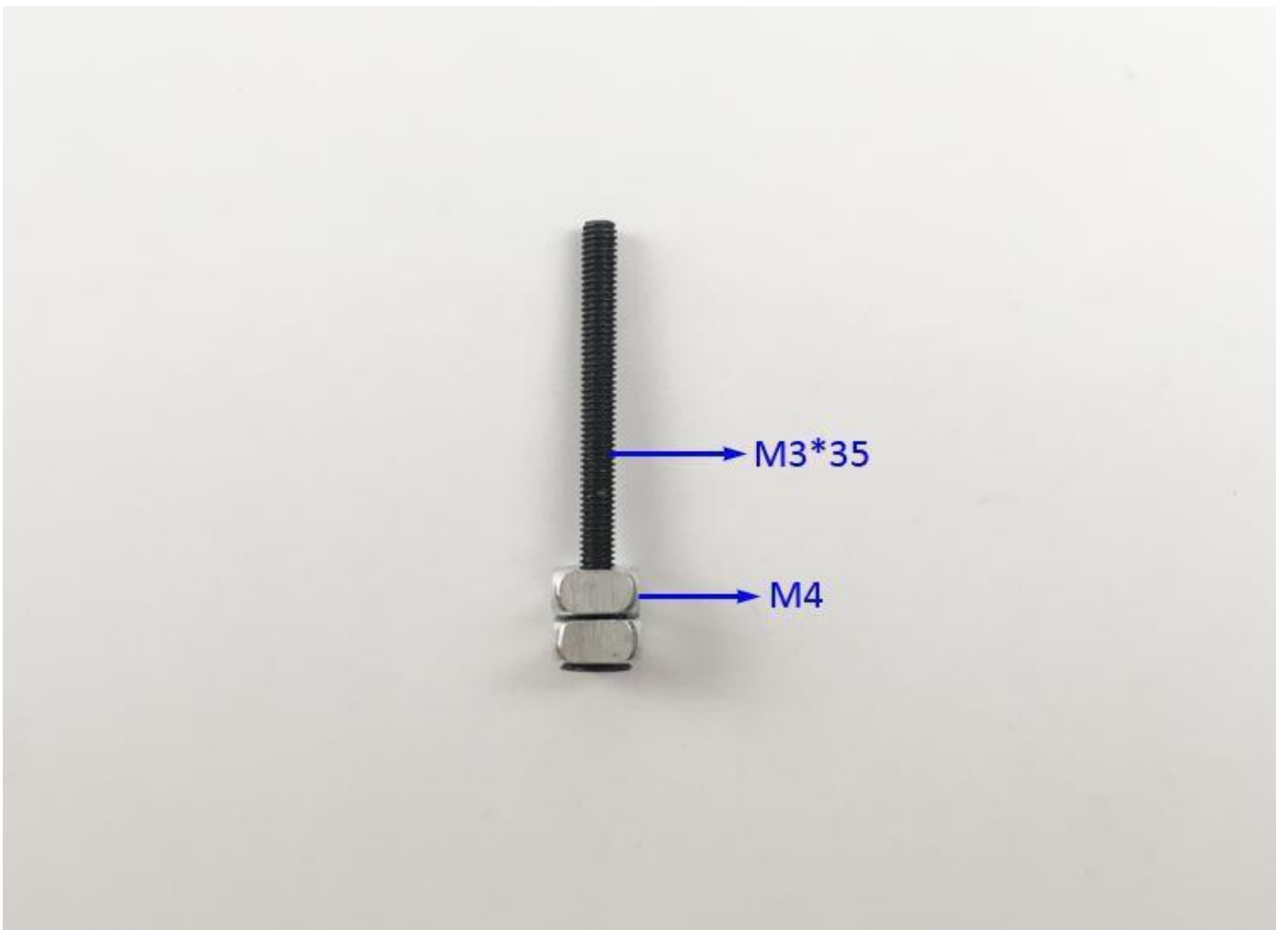



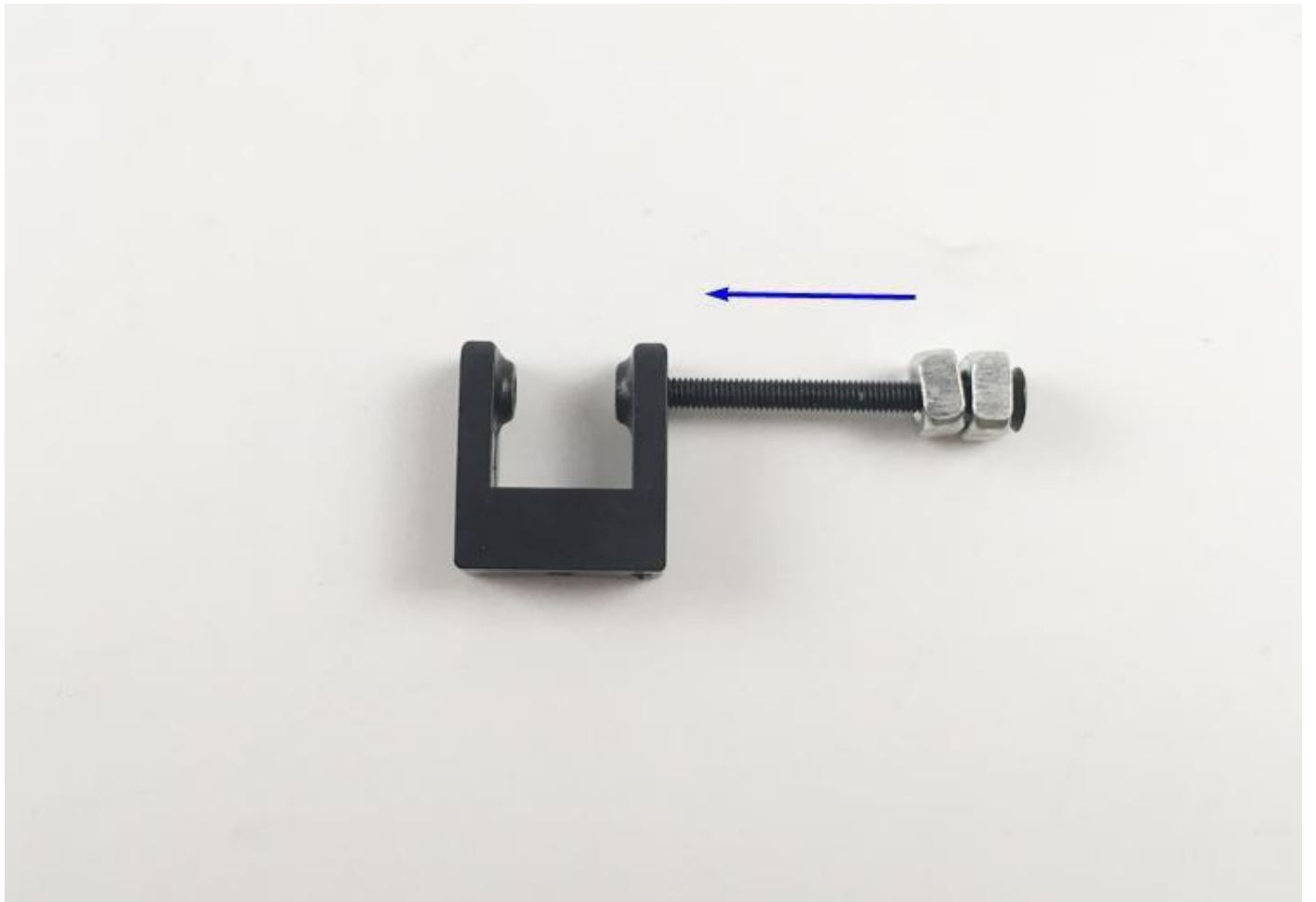



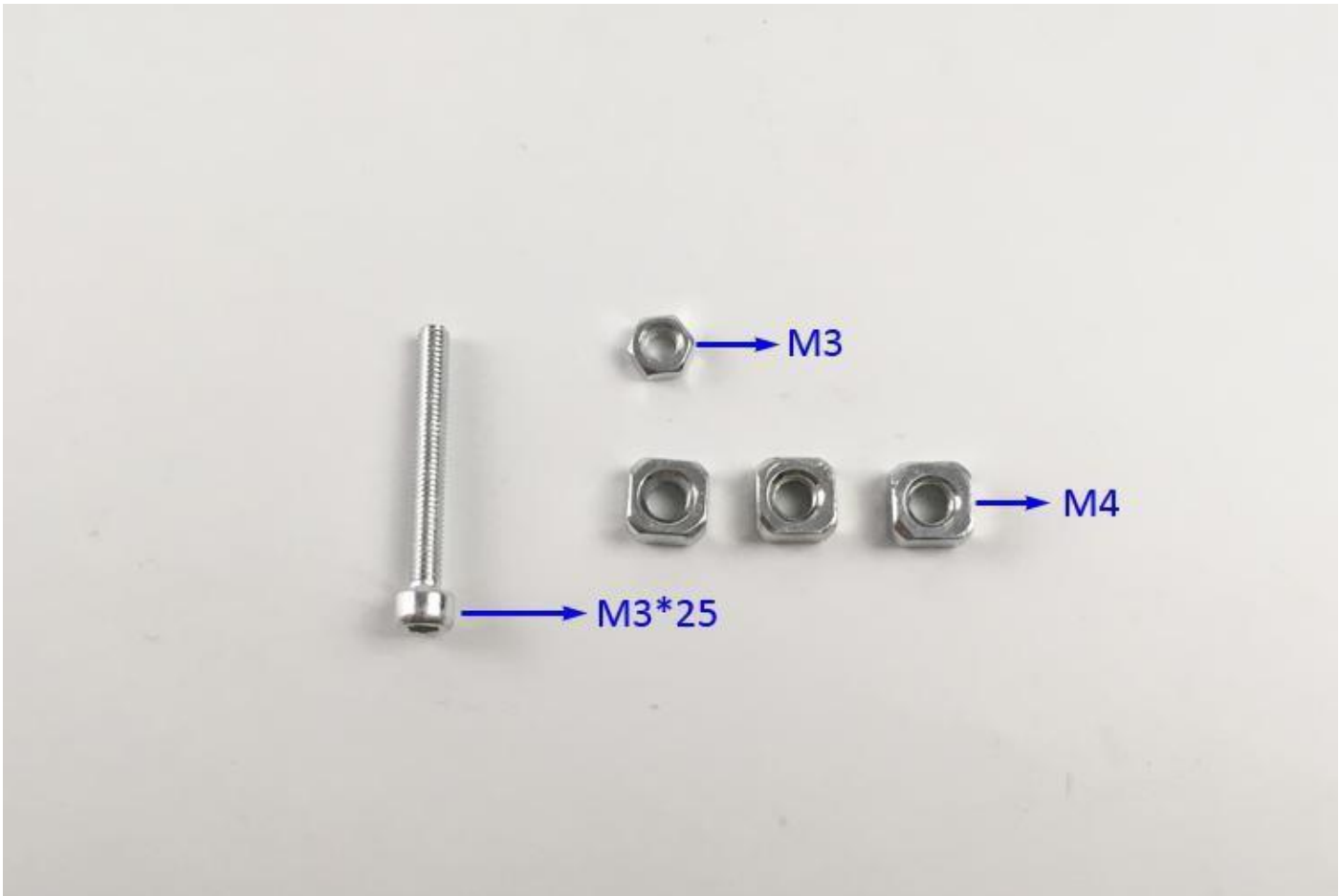

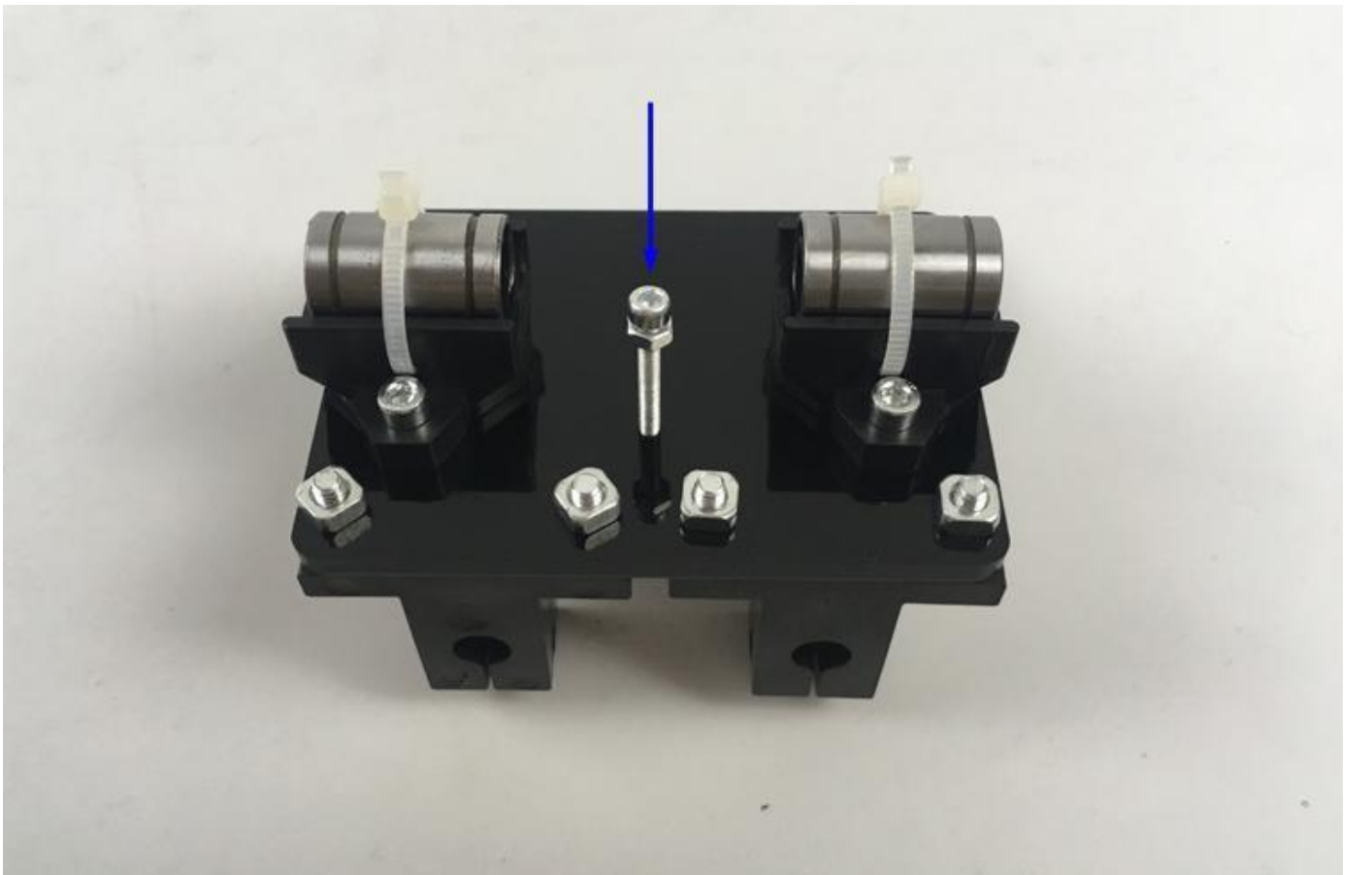
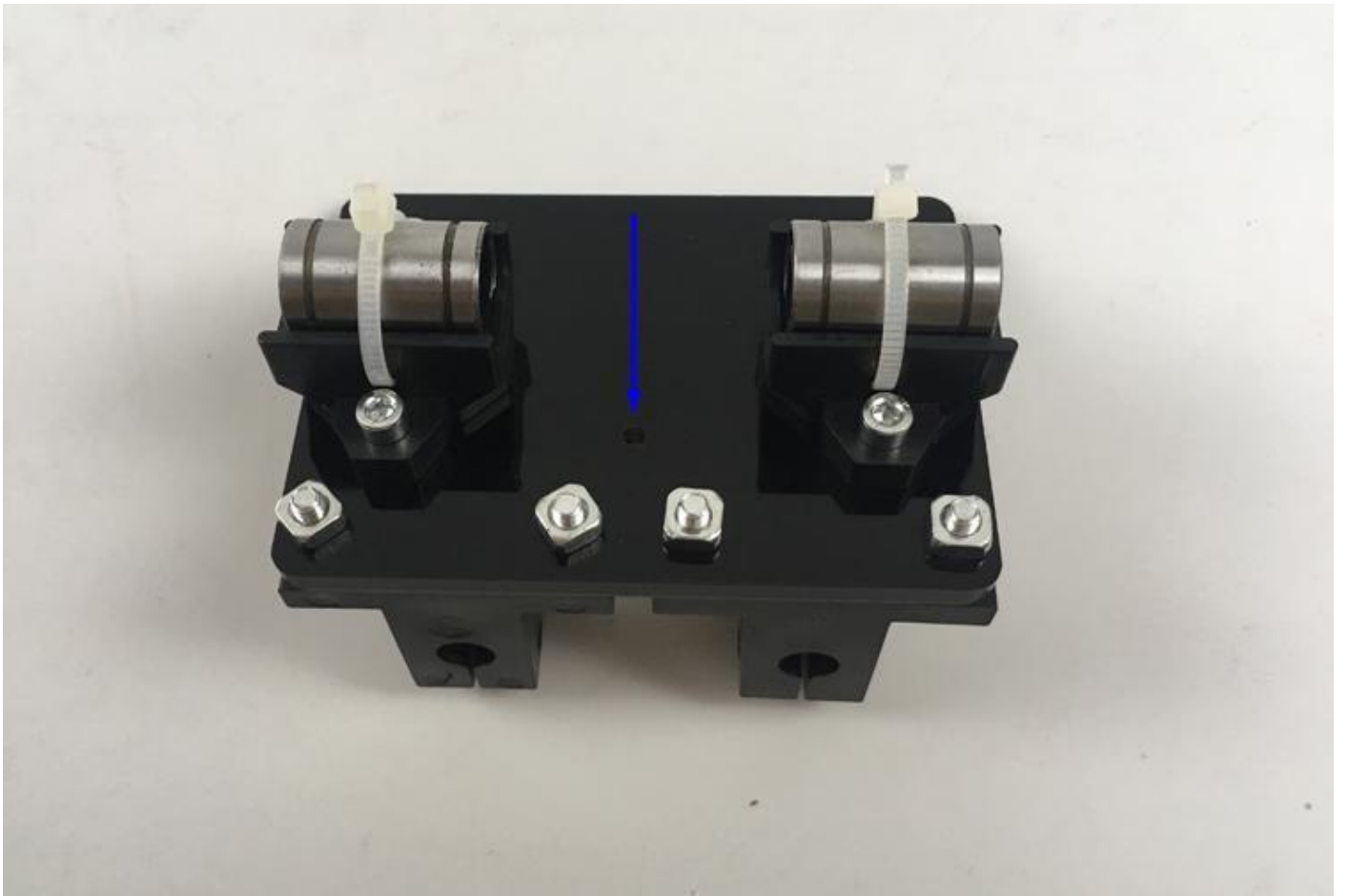

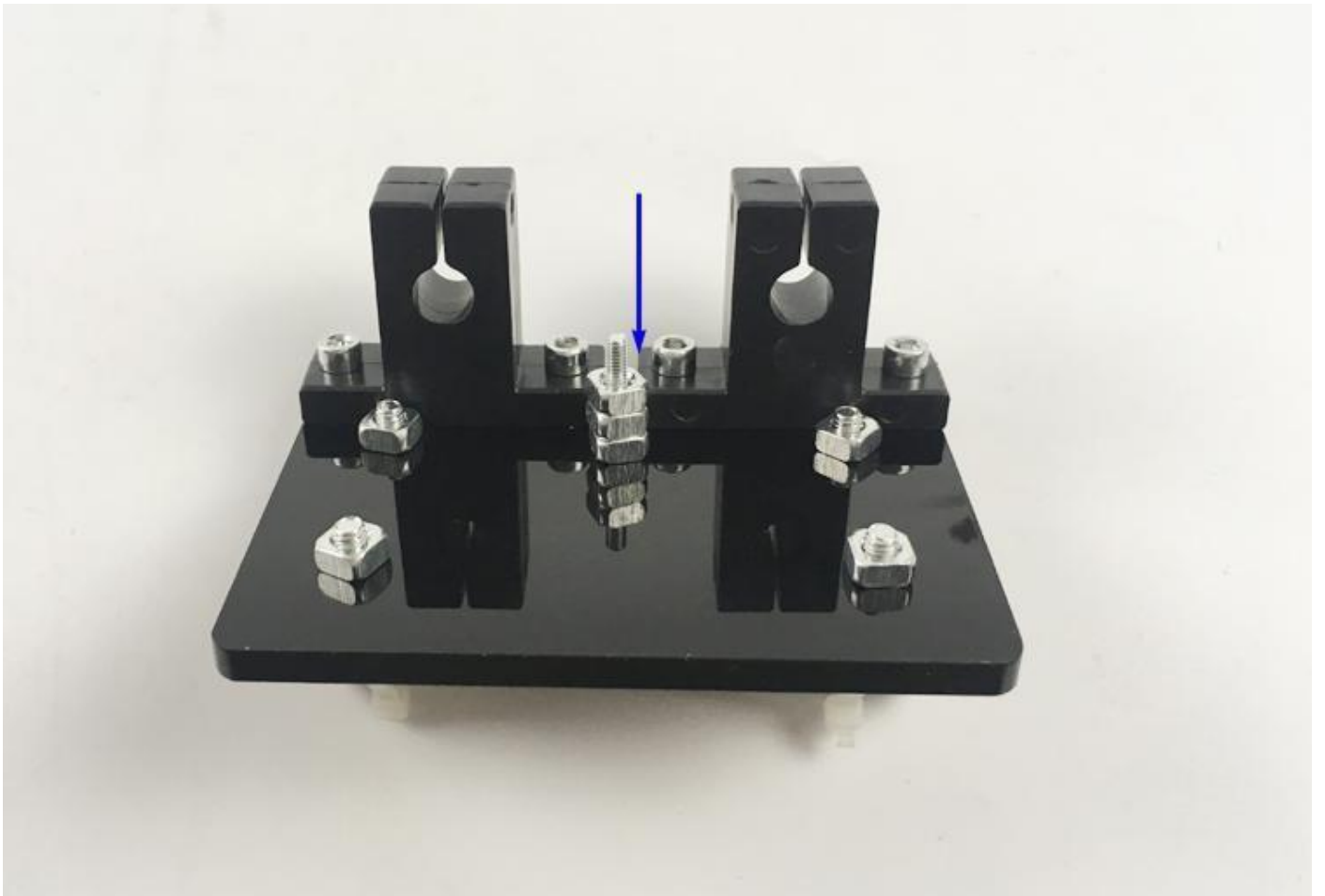
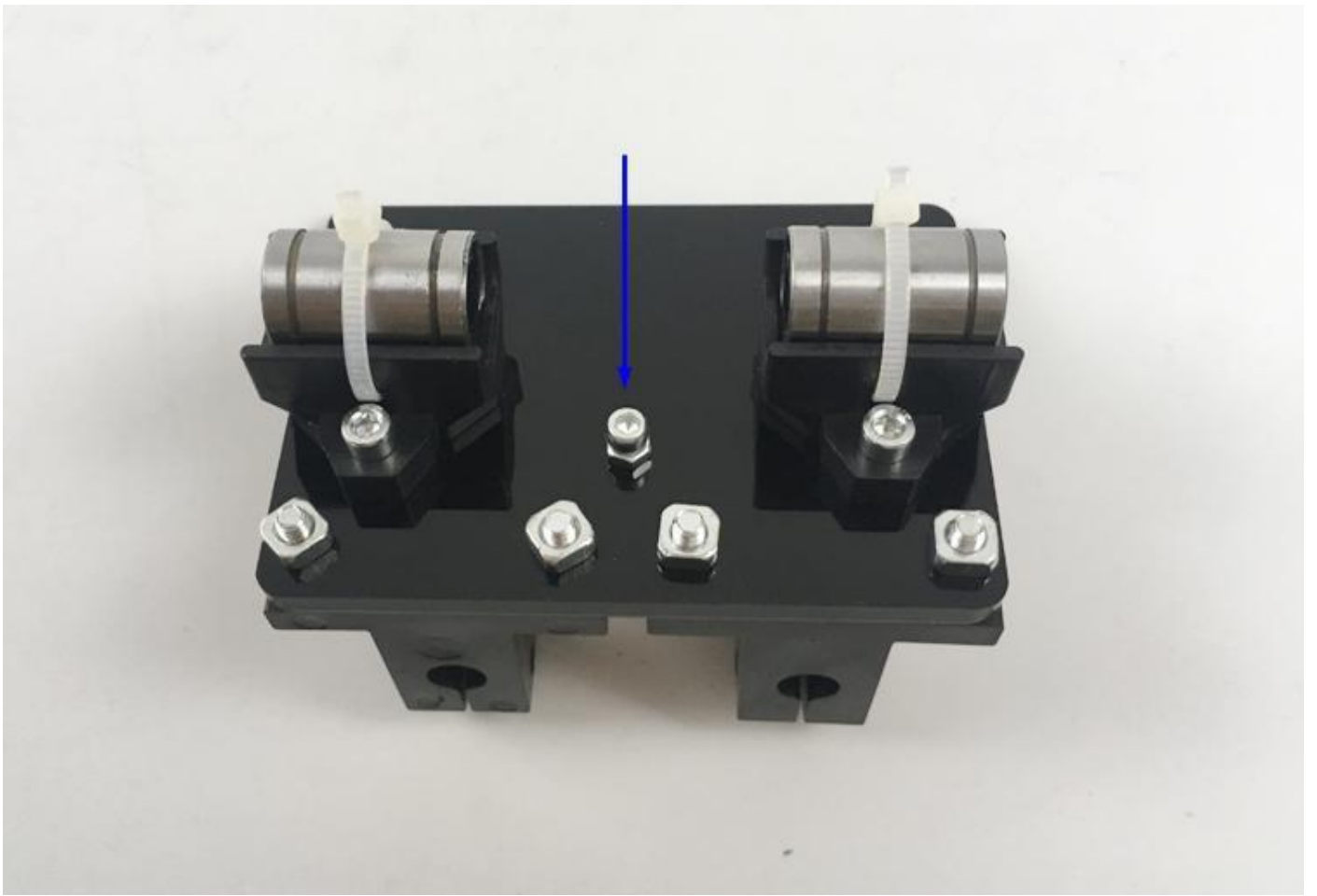

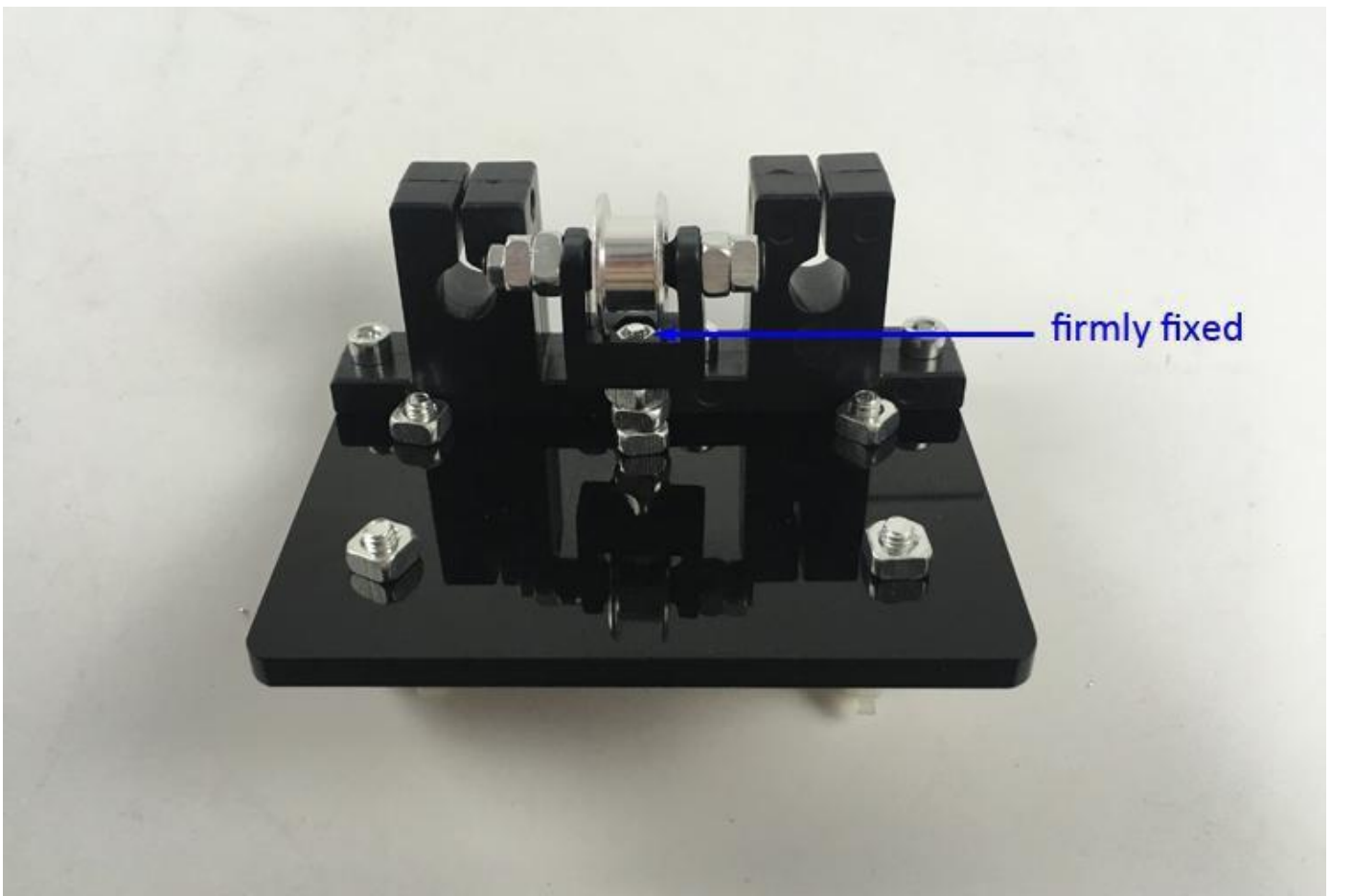
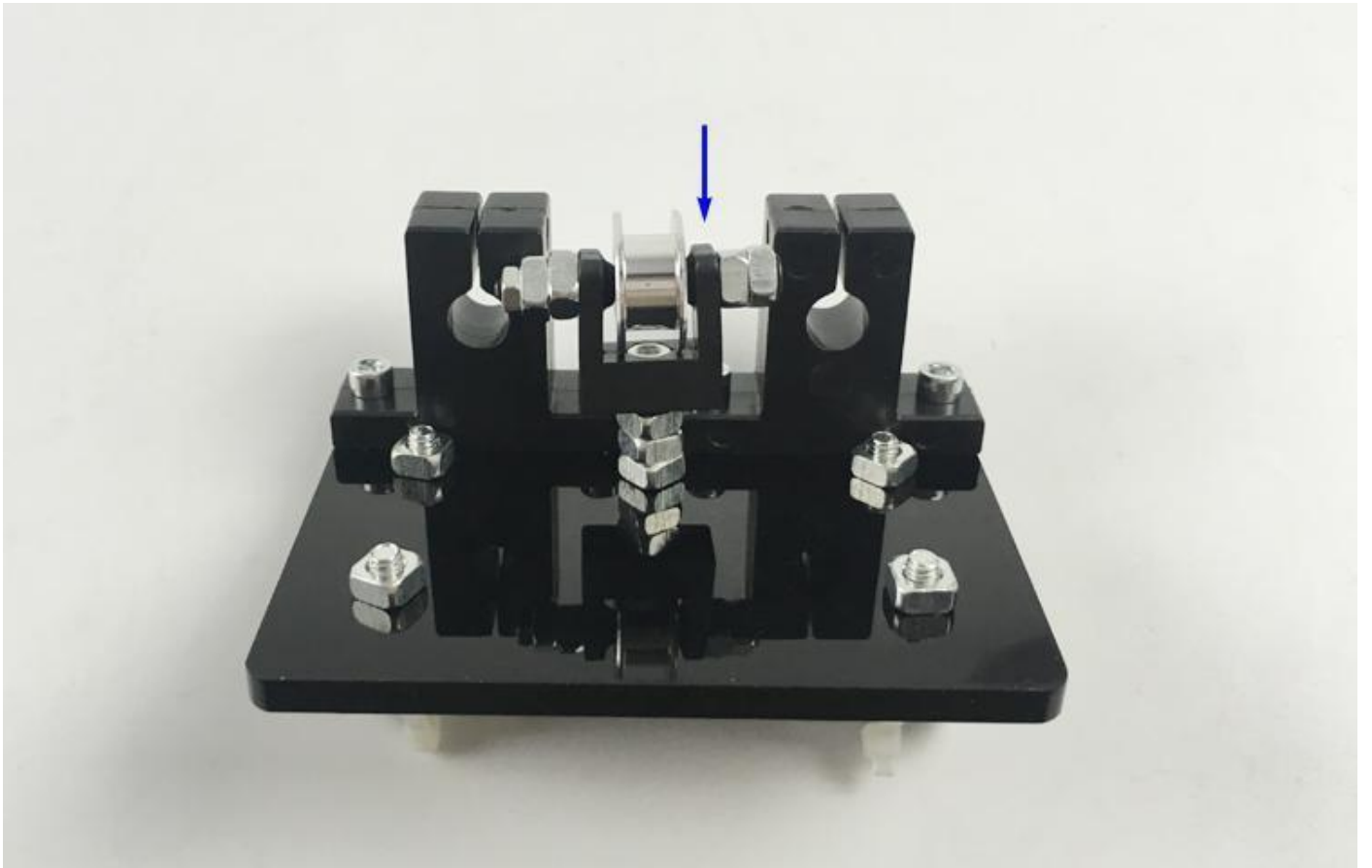

this help block the H wheel rotate too much

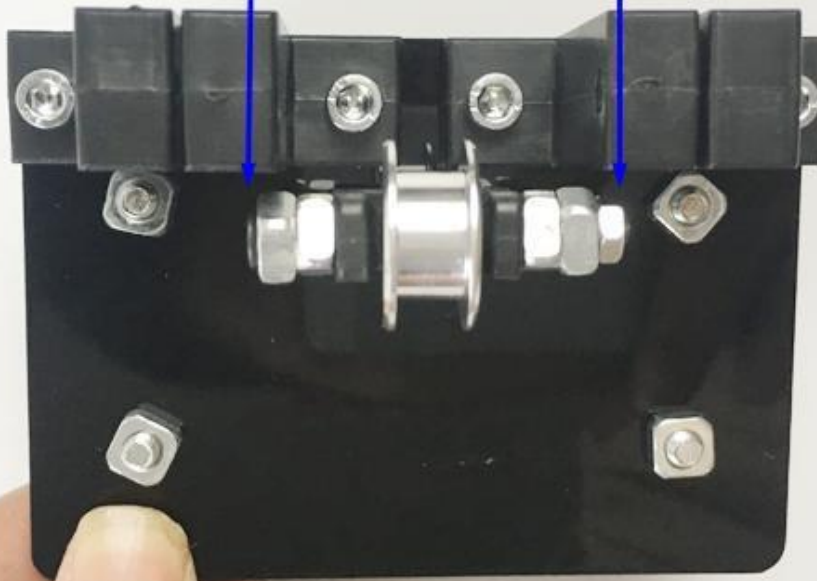

Overlooking, this angle !!!

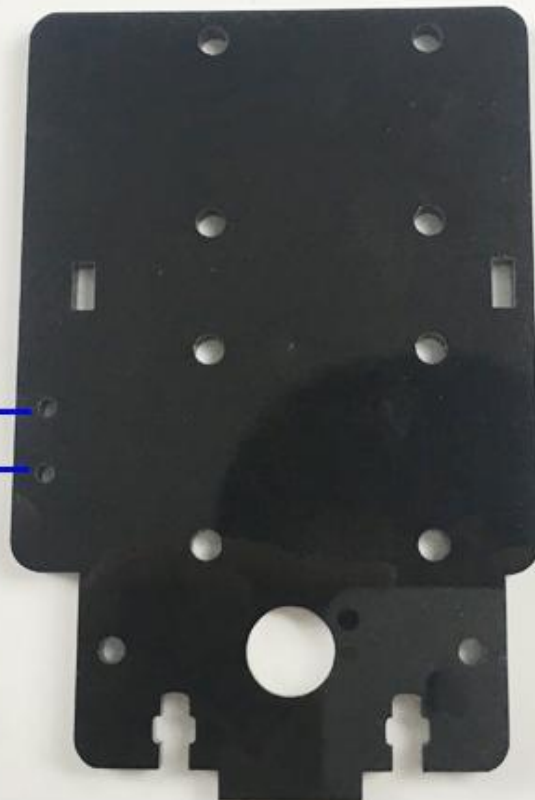

these two holes  
are X limit switch.  
must in the left!!!

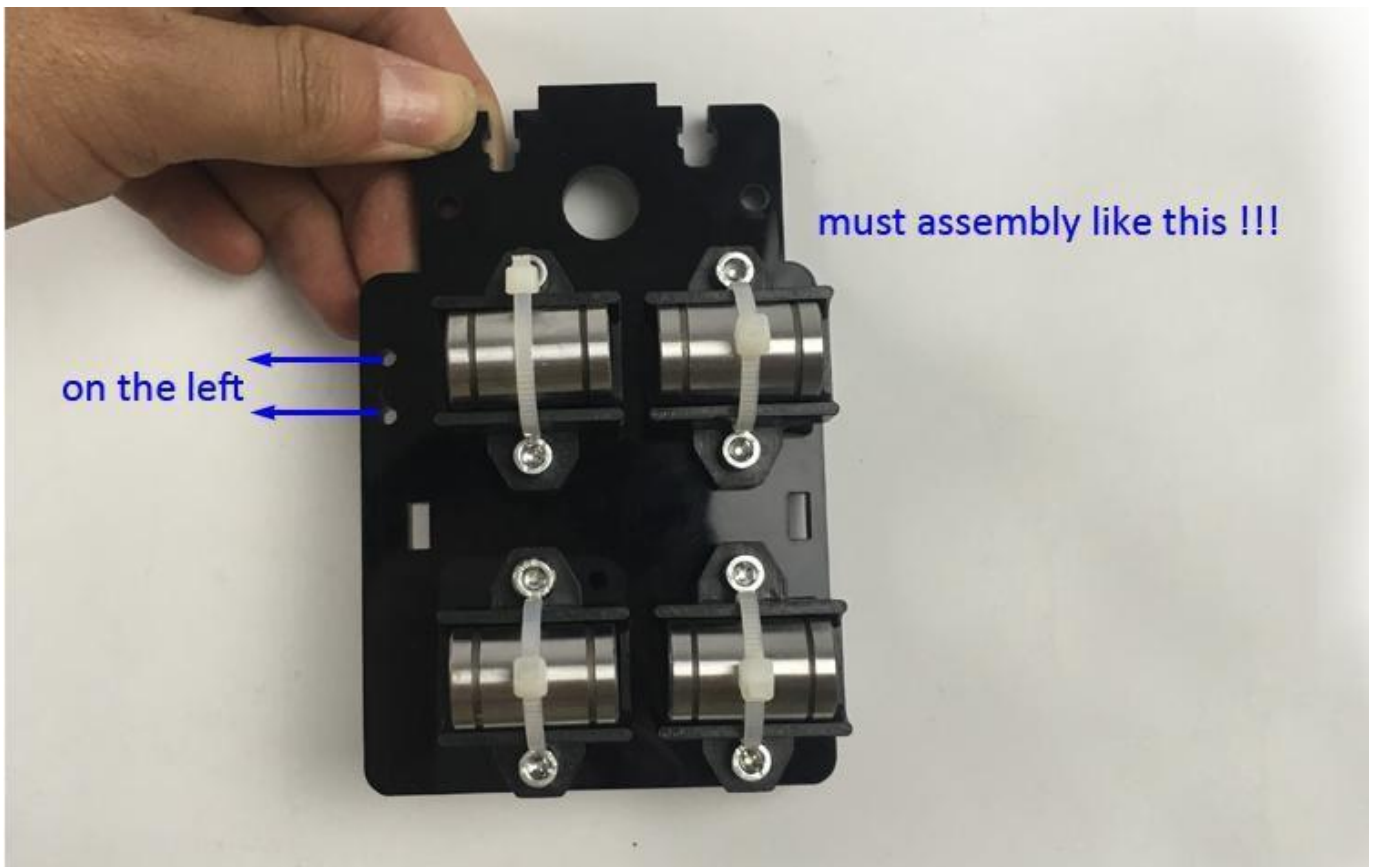



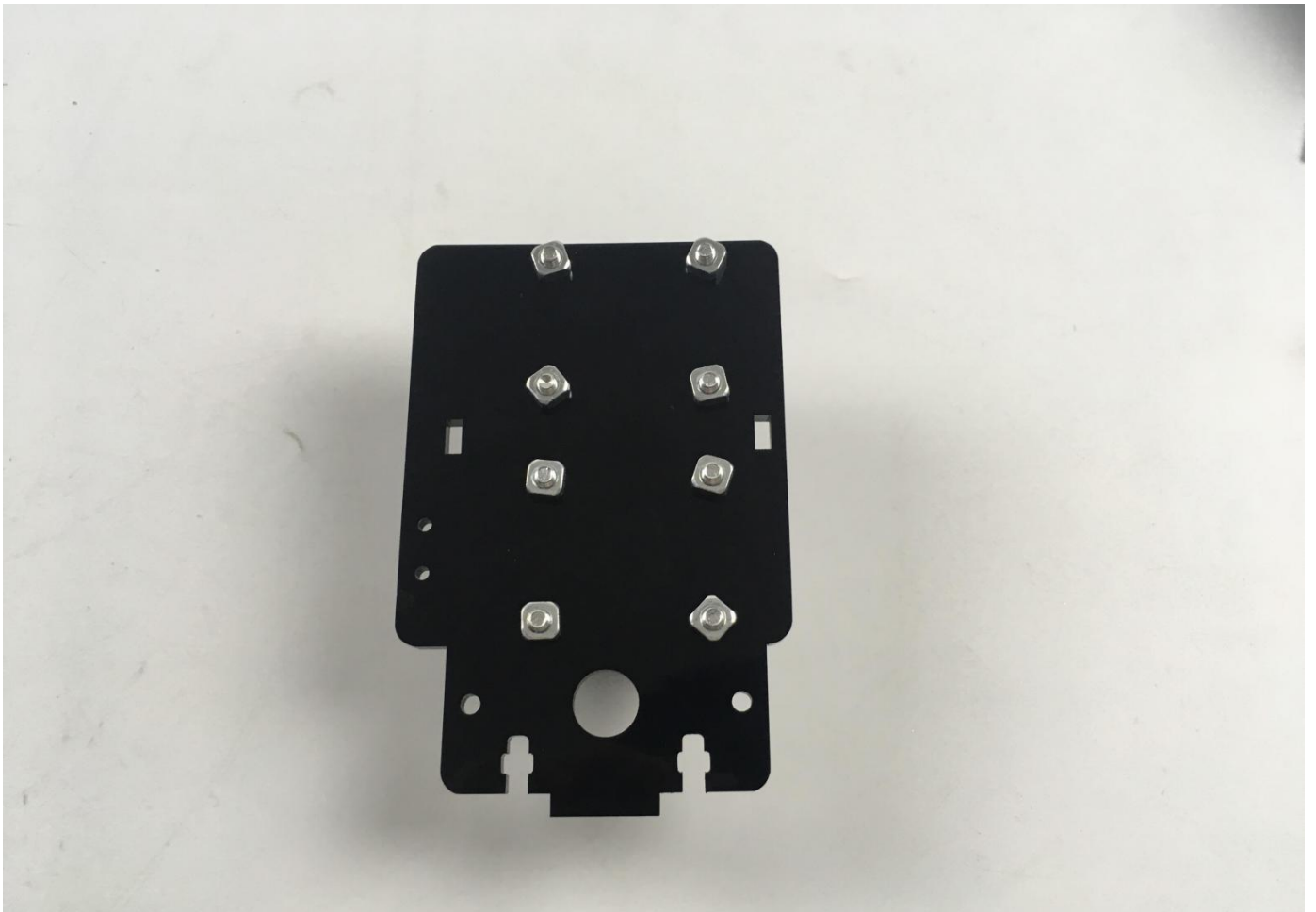



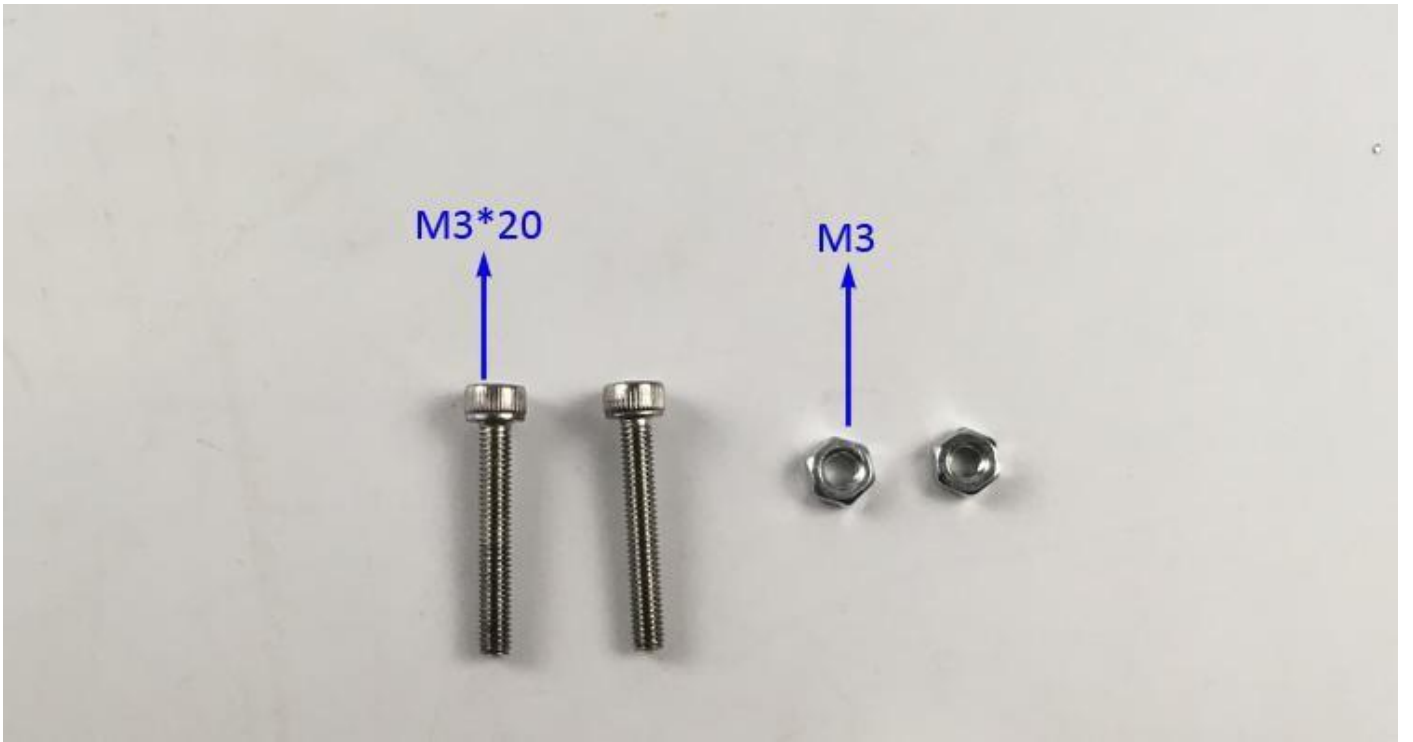

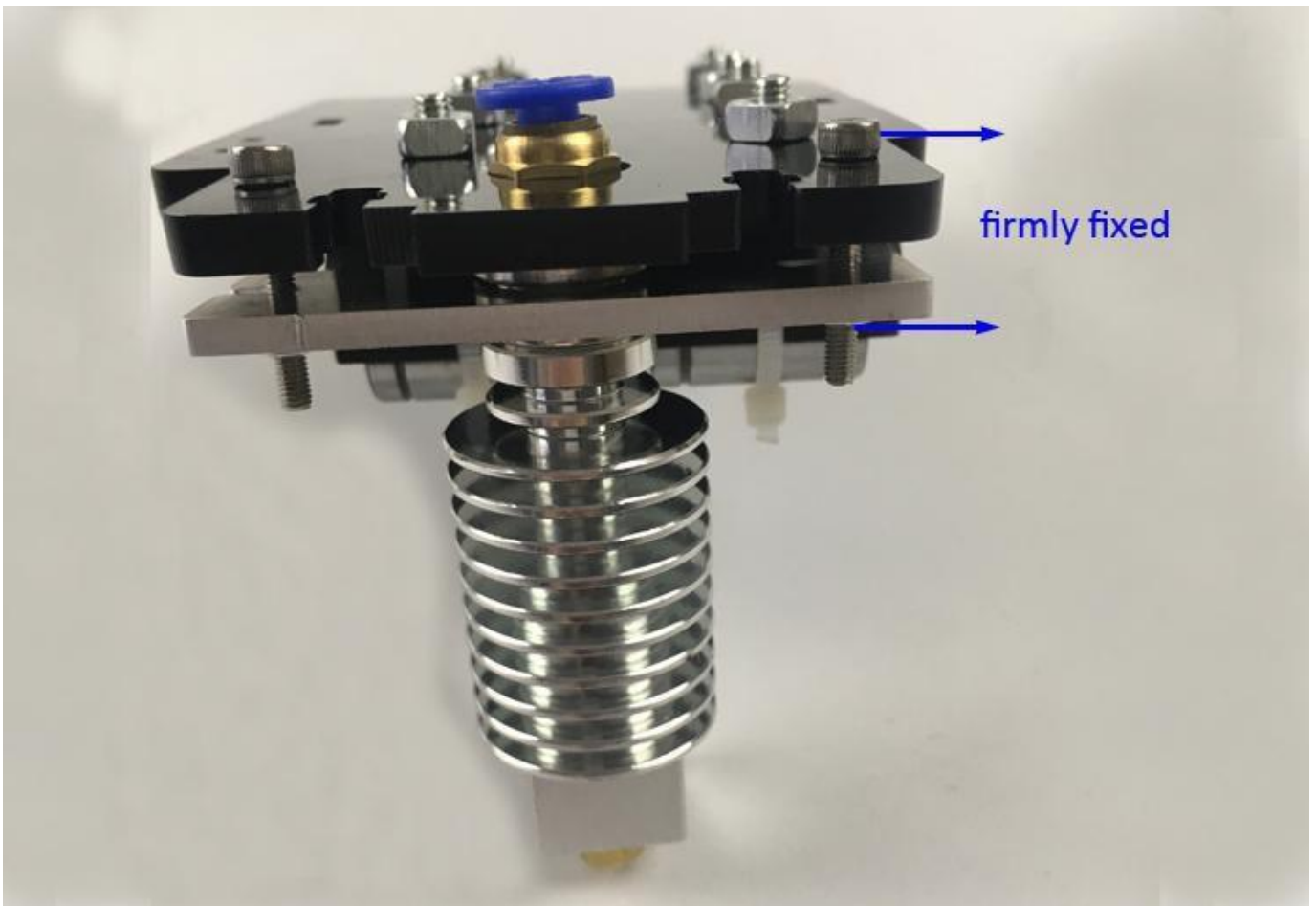
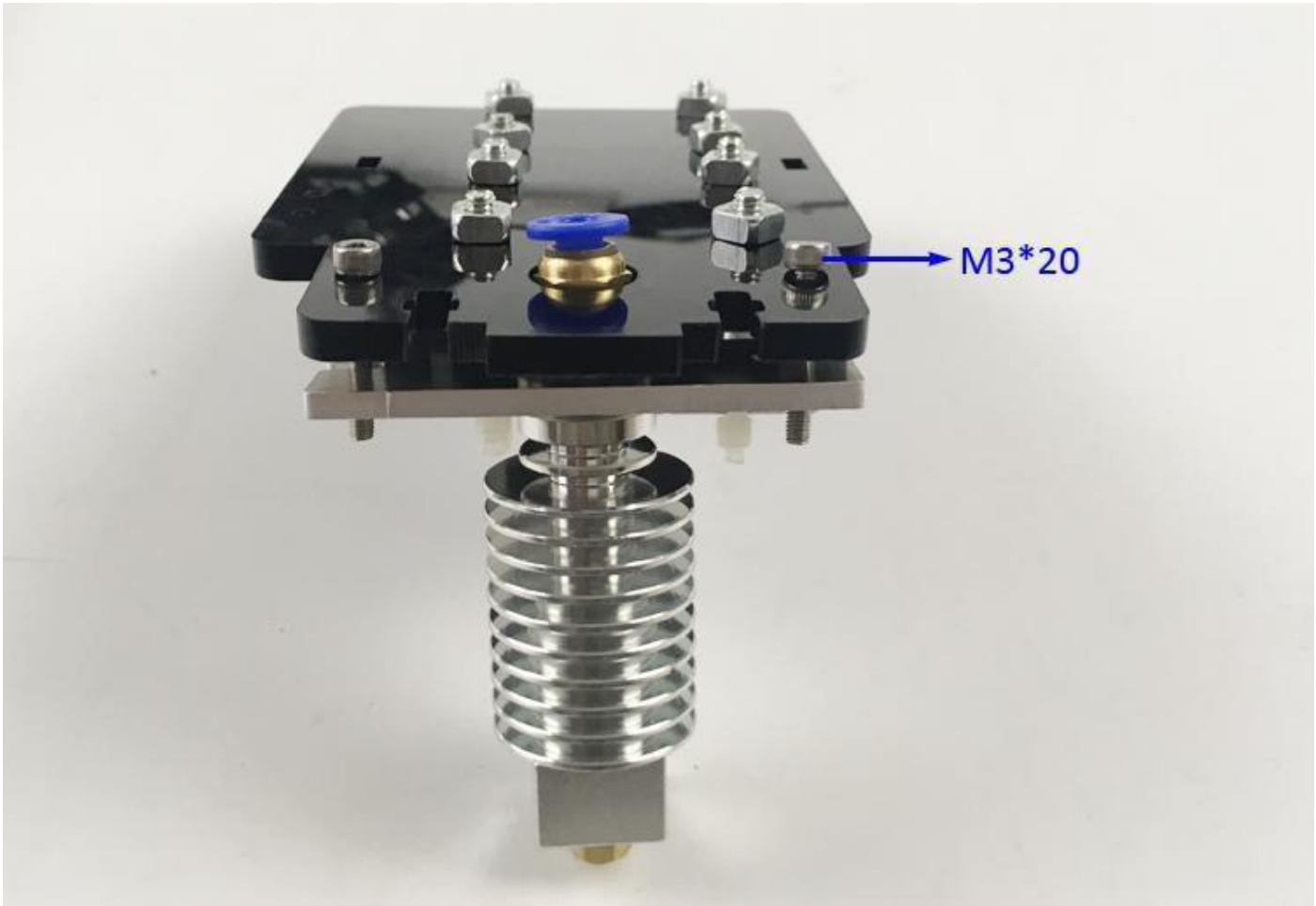

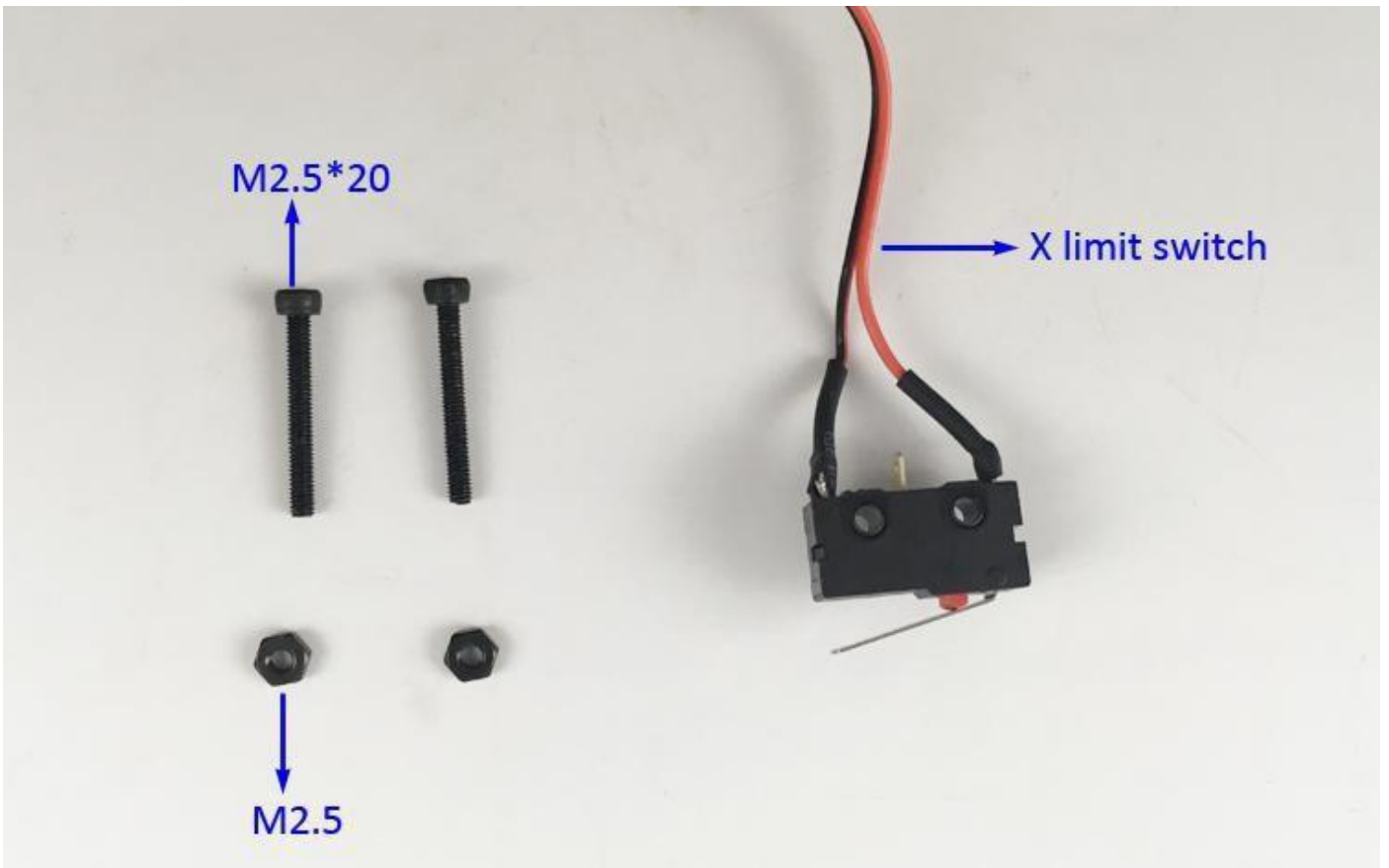

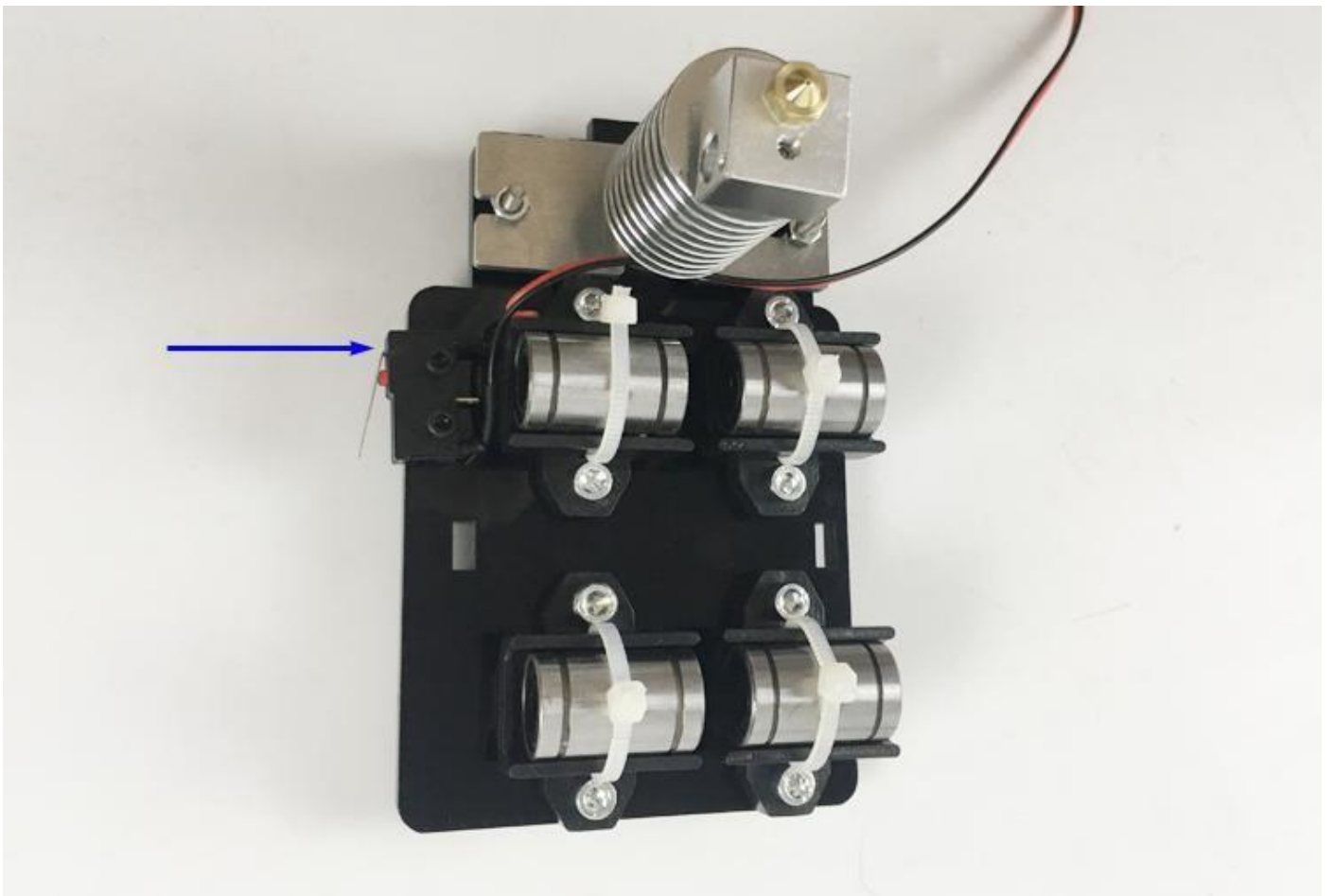
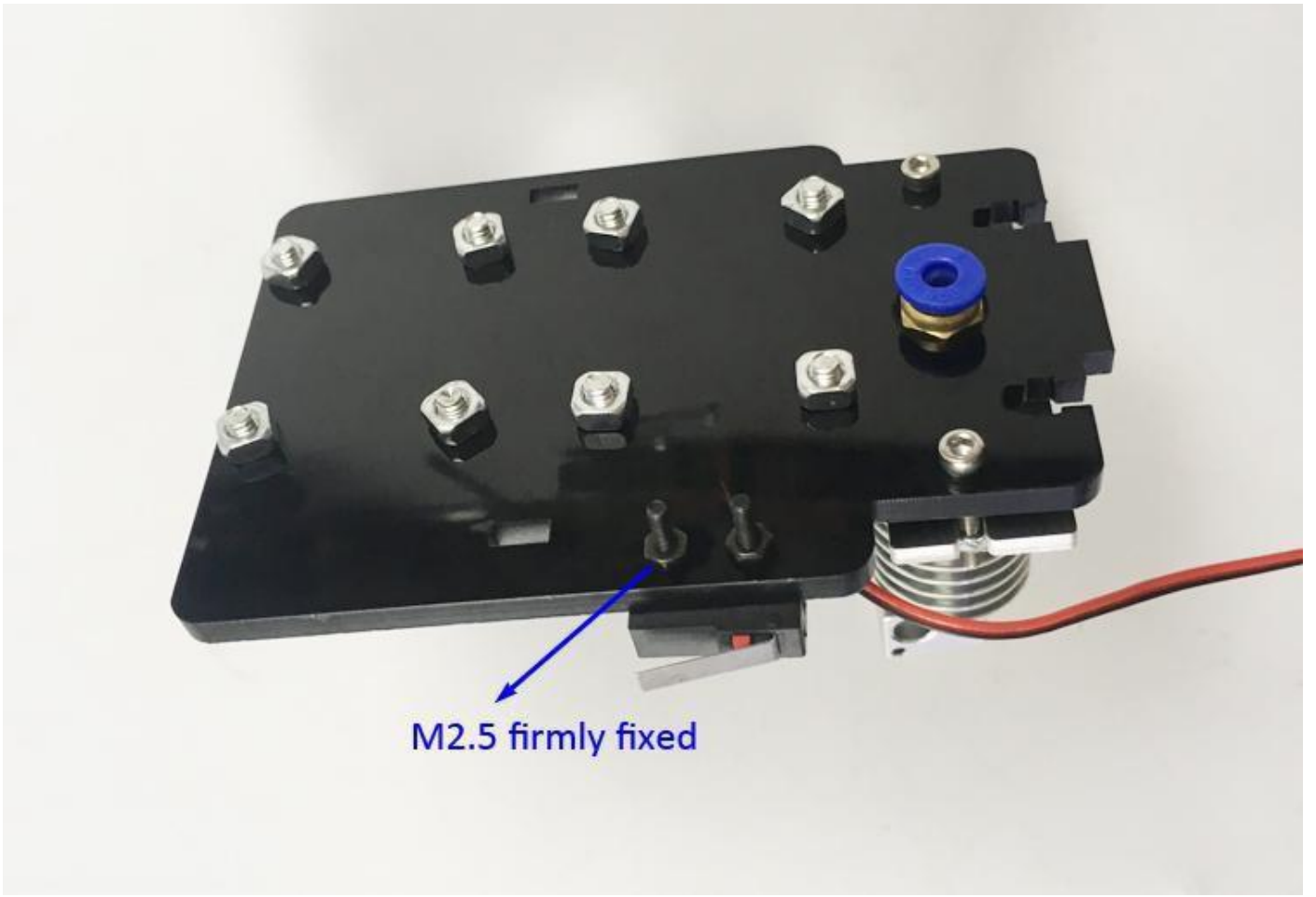

# Install the auto leveling sensor

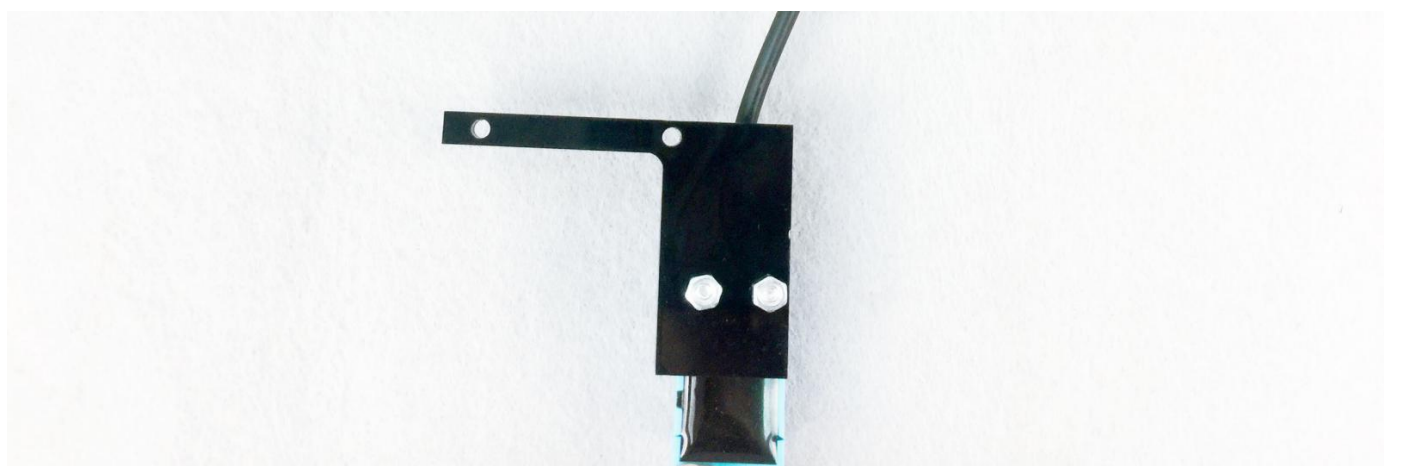
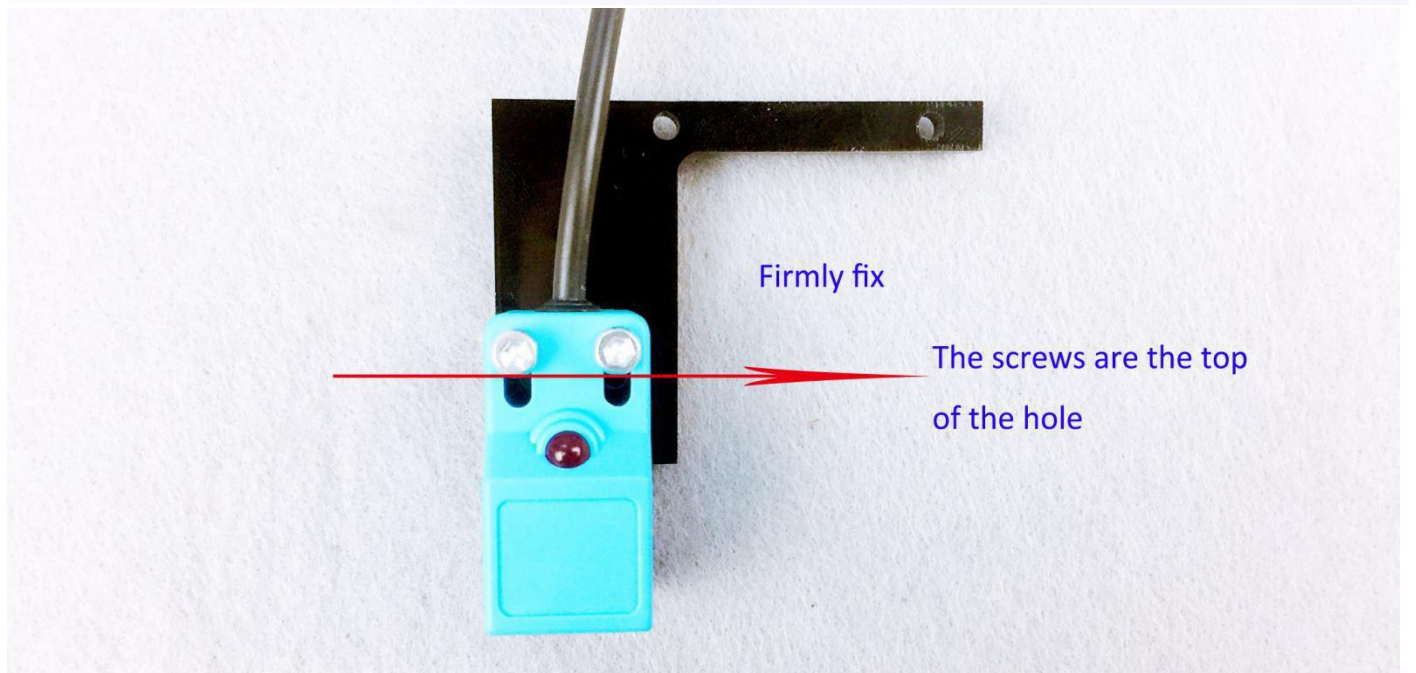
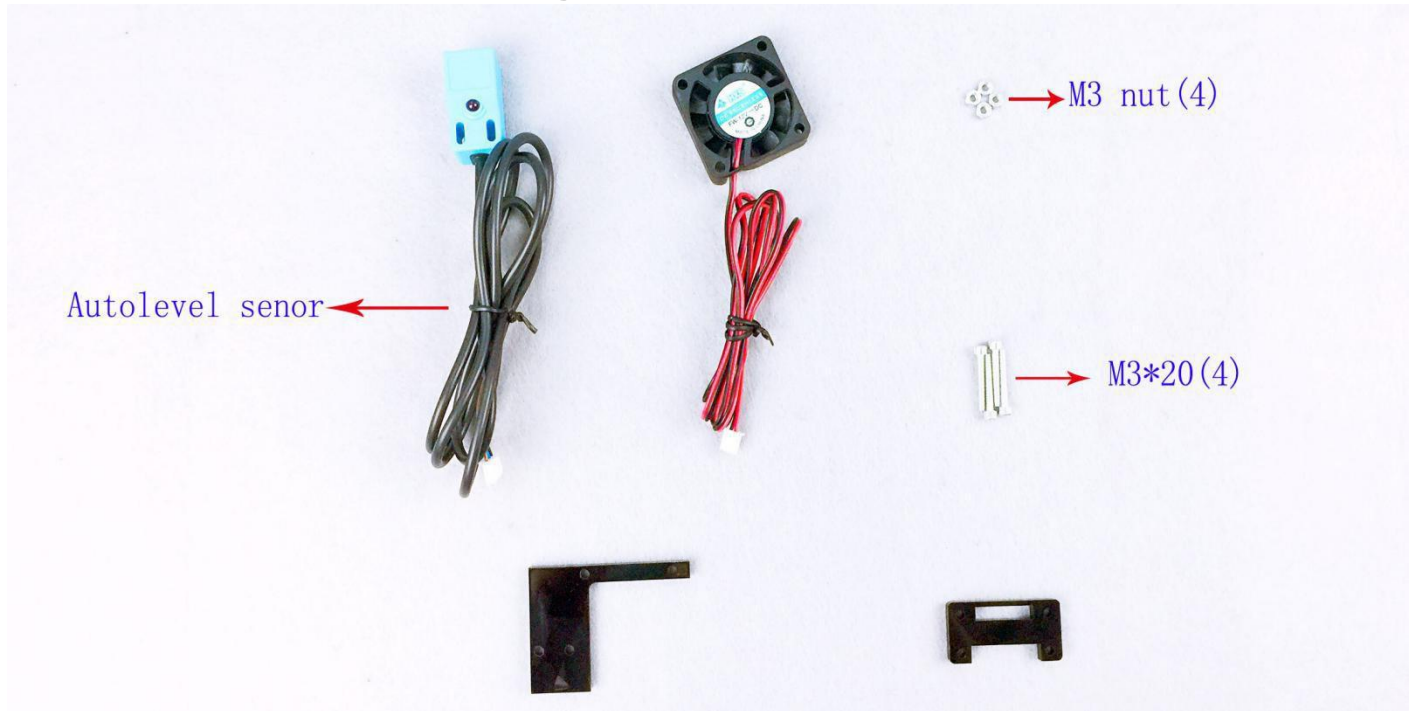

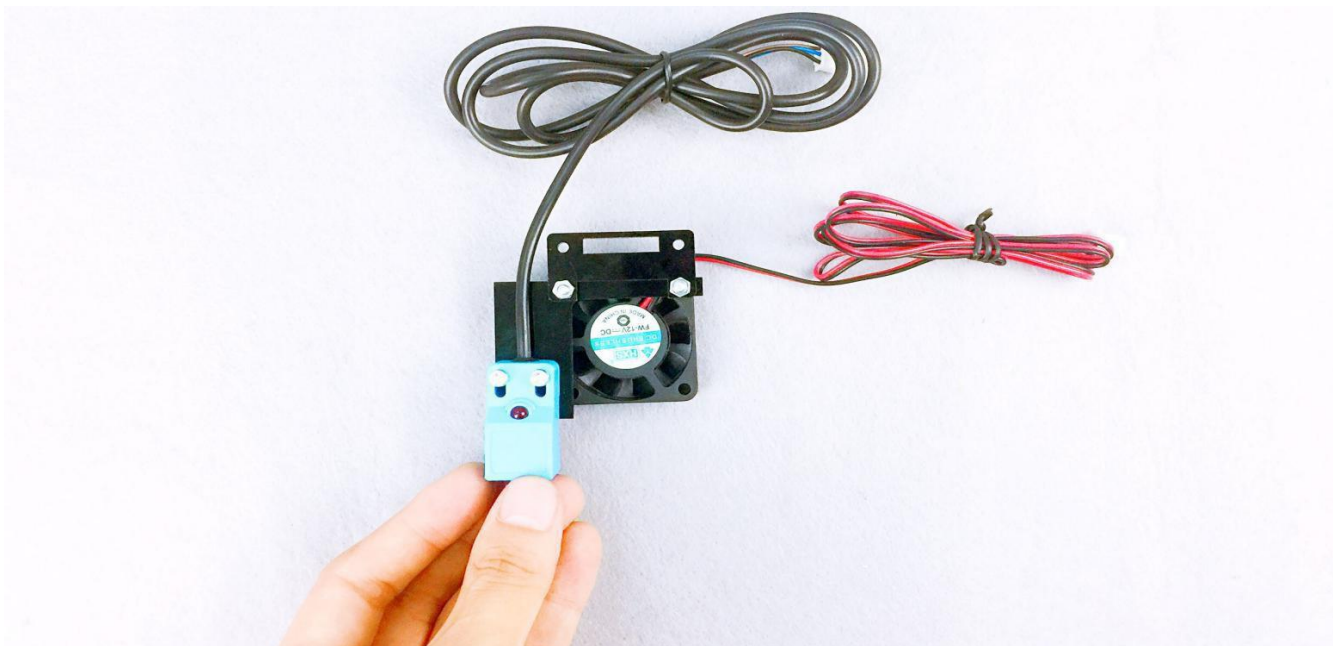
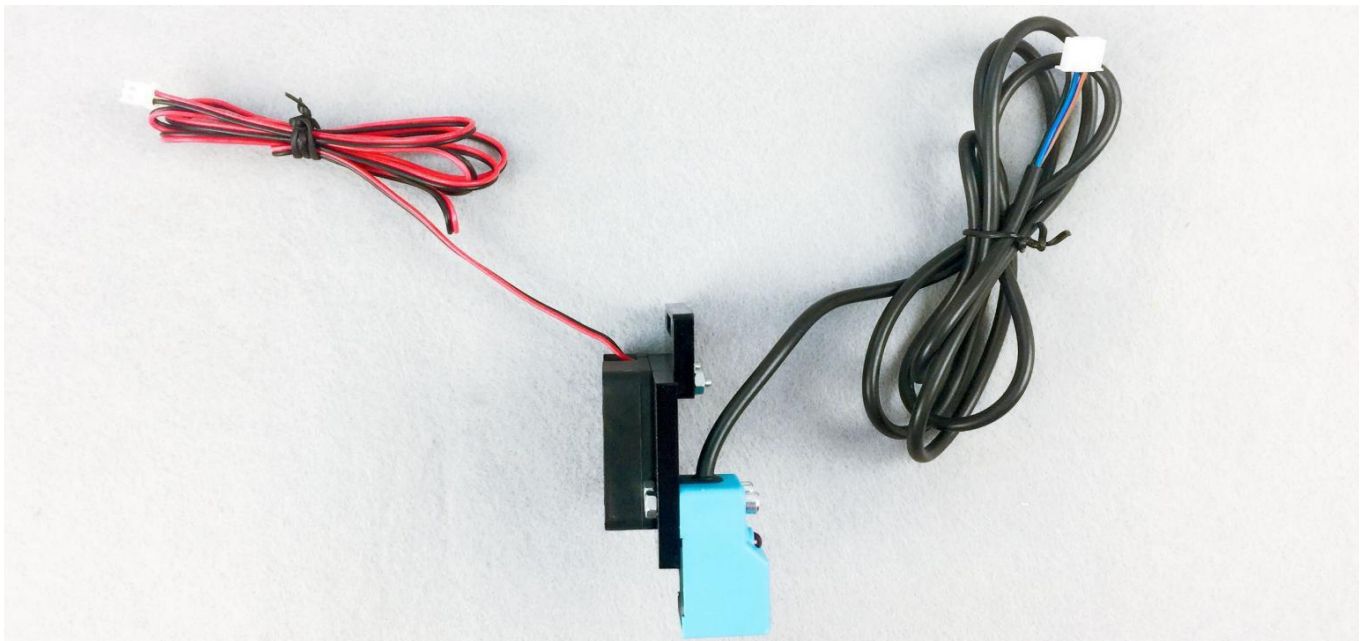
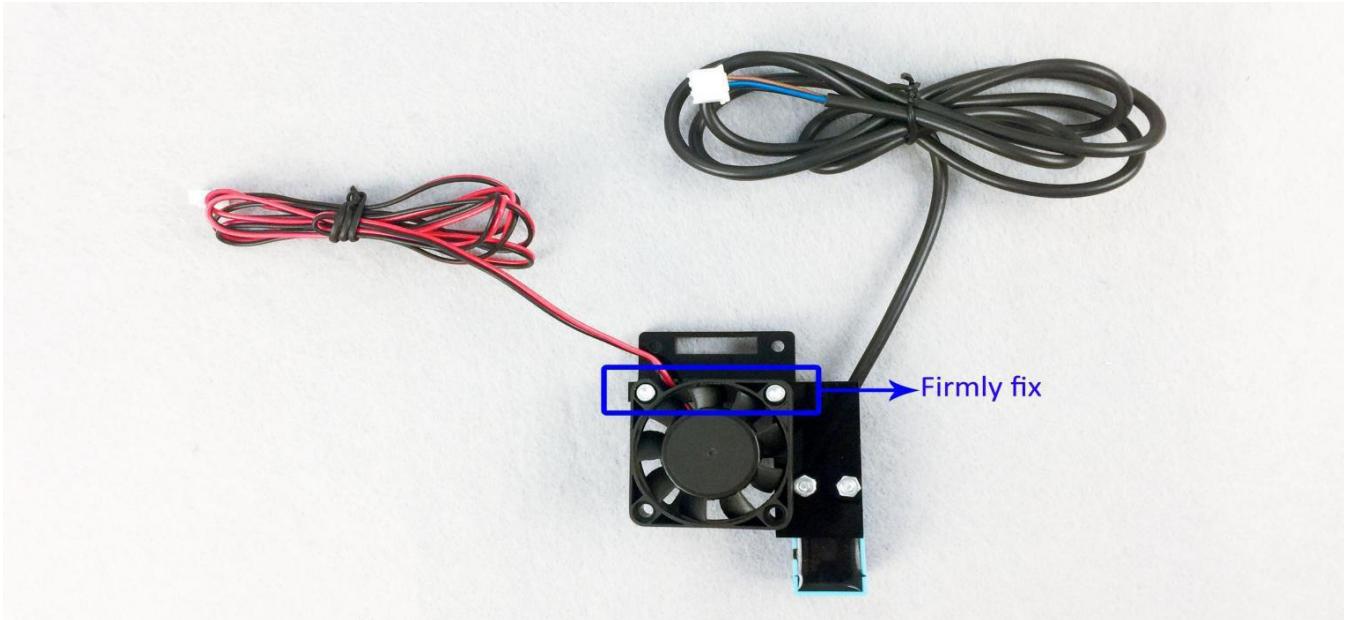



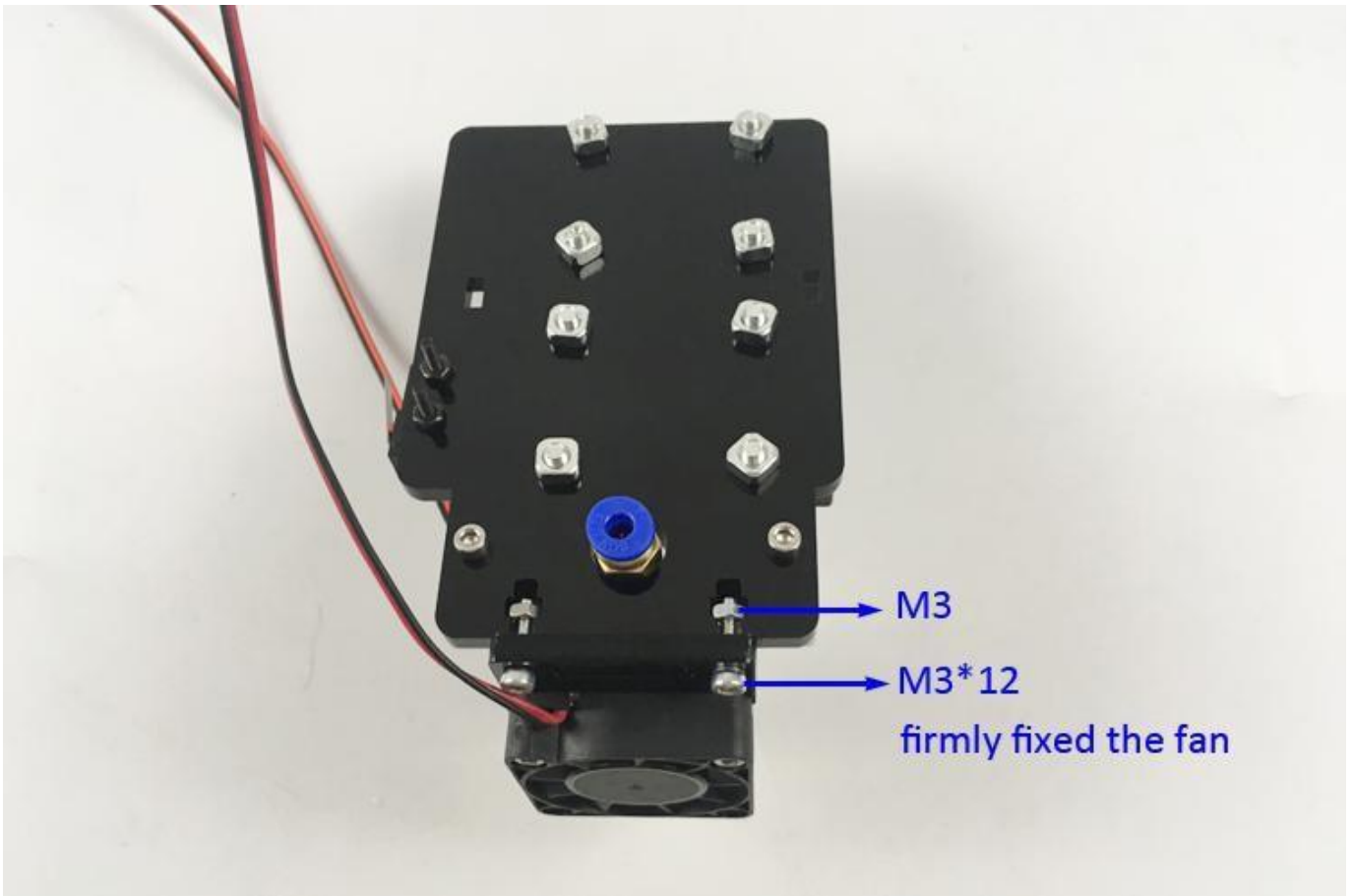

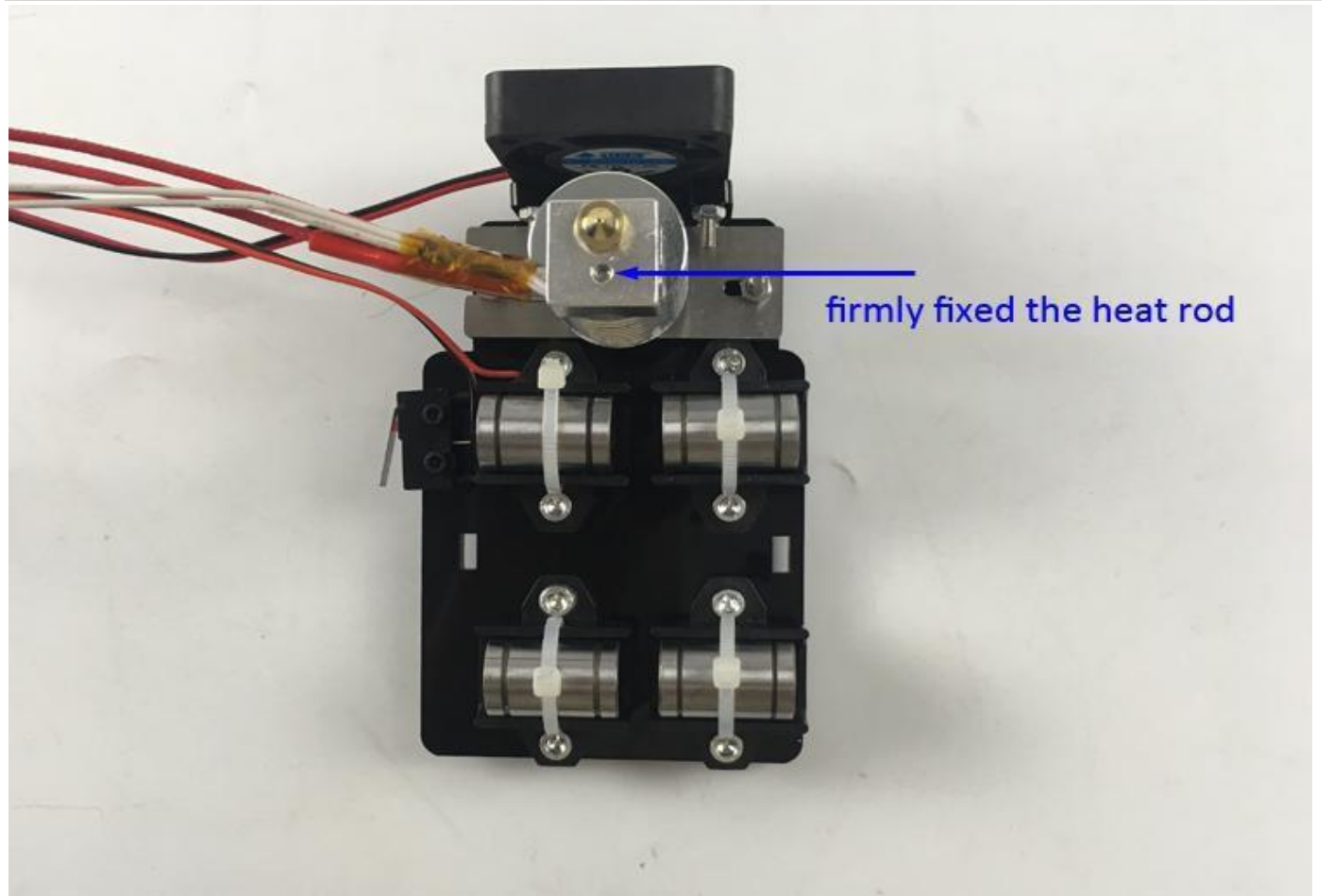
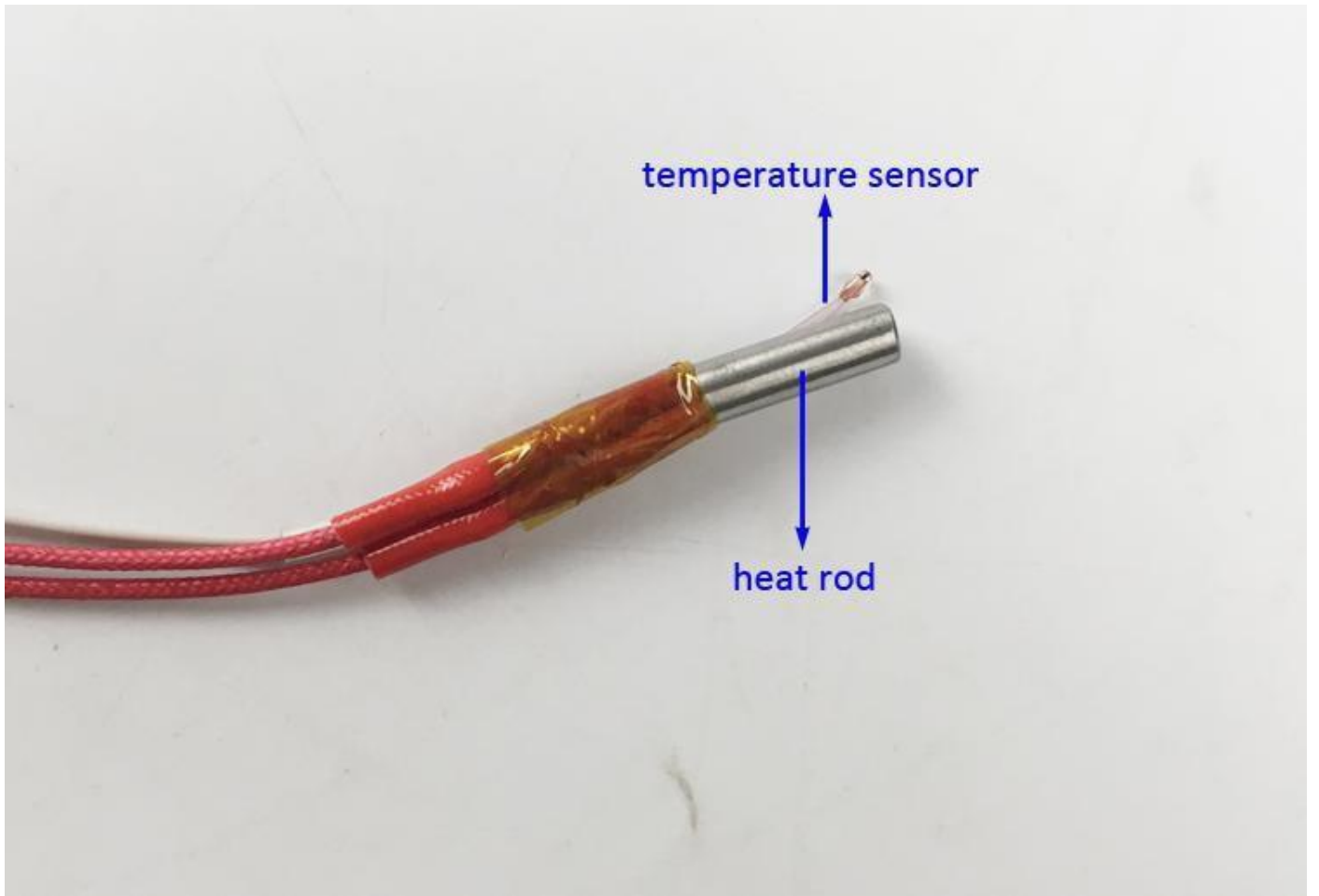

The temperature sensor is inserted into the specified hole,  
the screw is pressed against one of the threads, then firmly fix the screw,  
taking care not to damage the temperature sensor

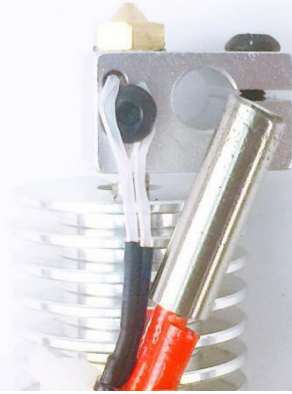

Insert the heating bar into the specified hole

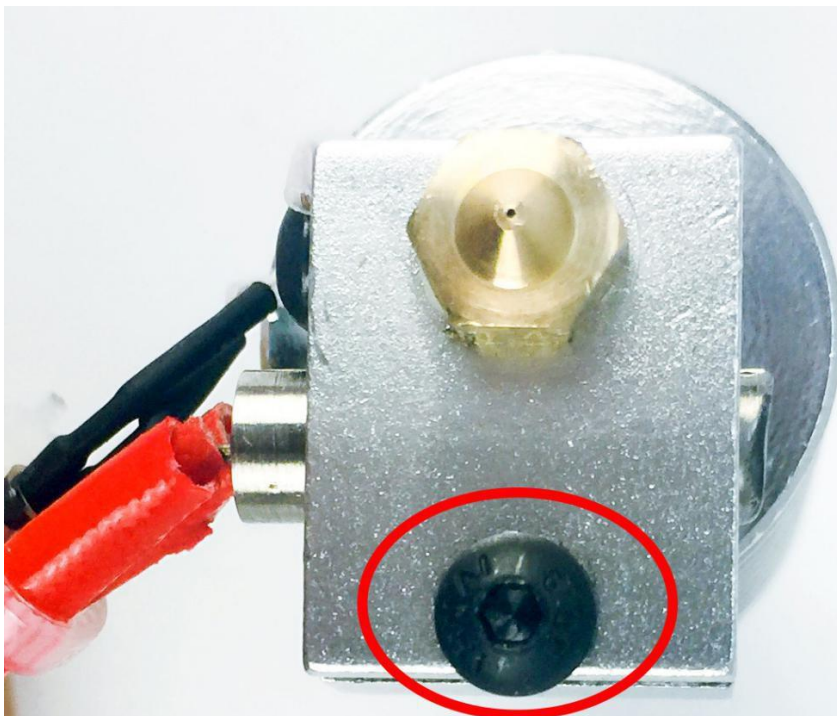
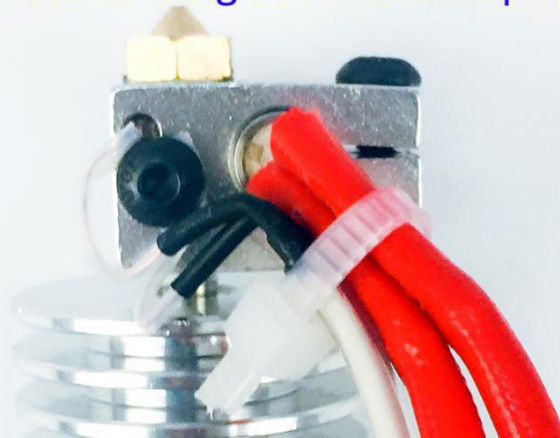

Then firmly fix the screw

500 mm rod

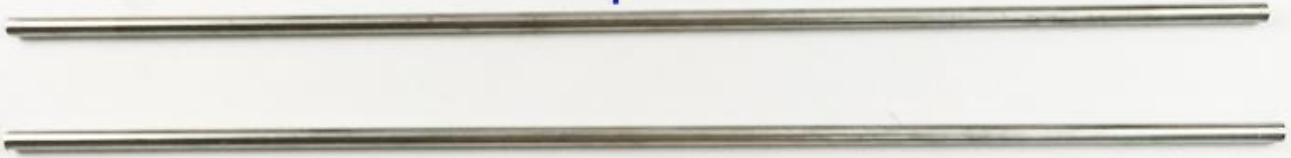

these rod maybe not absolute 500mm,maybe  $500\text{mm} \pm 3\text{mm}$ ,  
it's no problem and no matter,the rod only support moving.

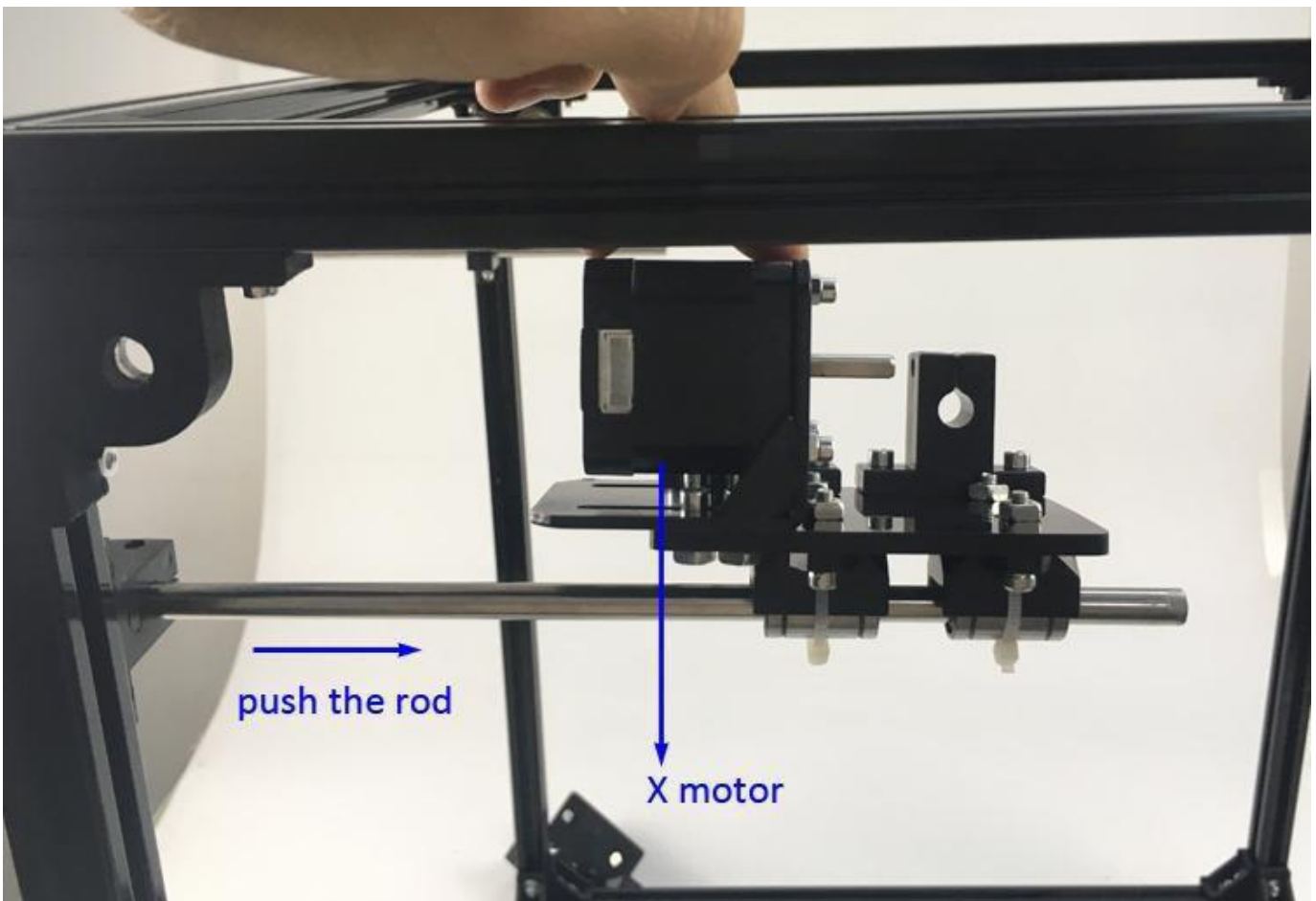

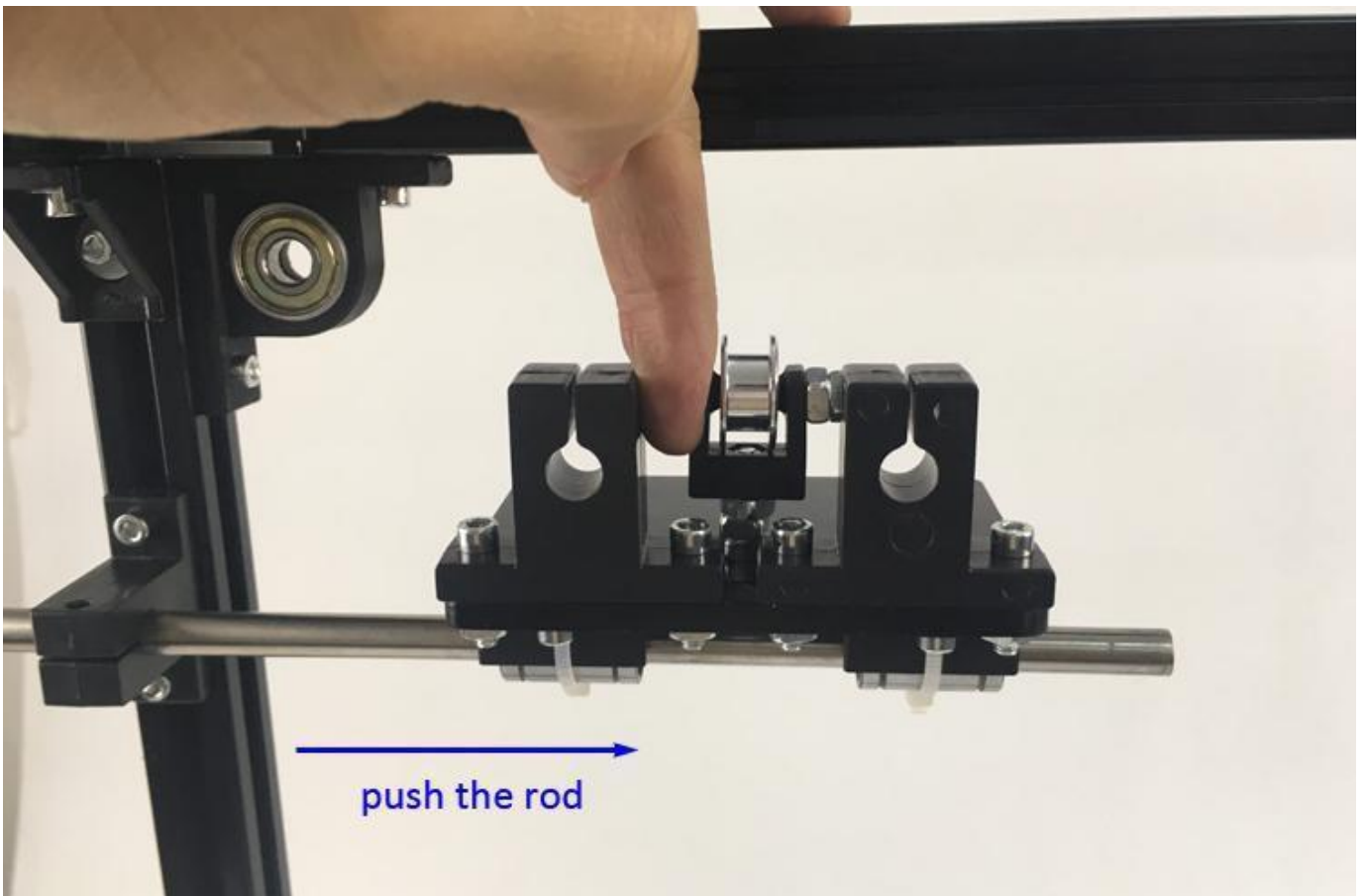
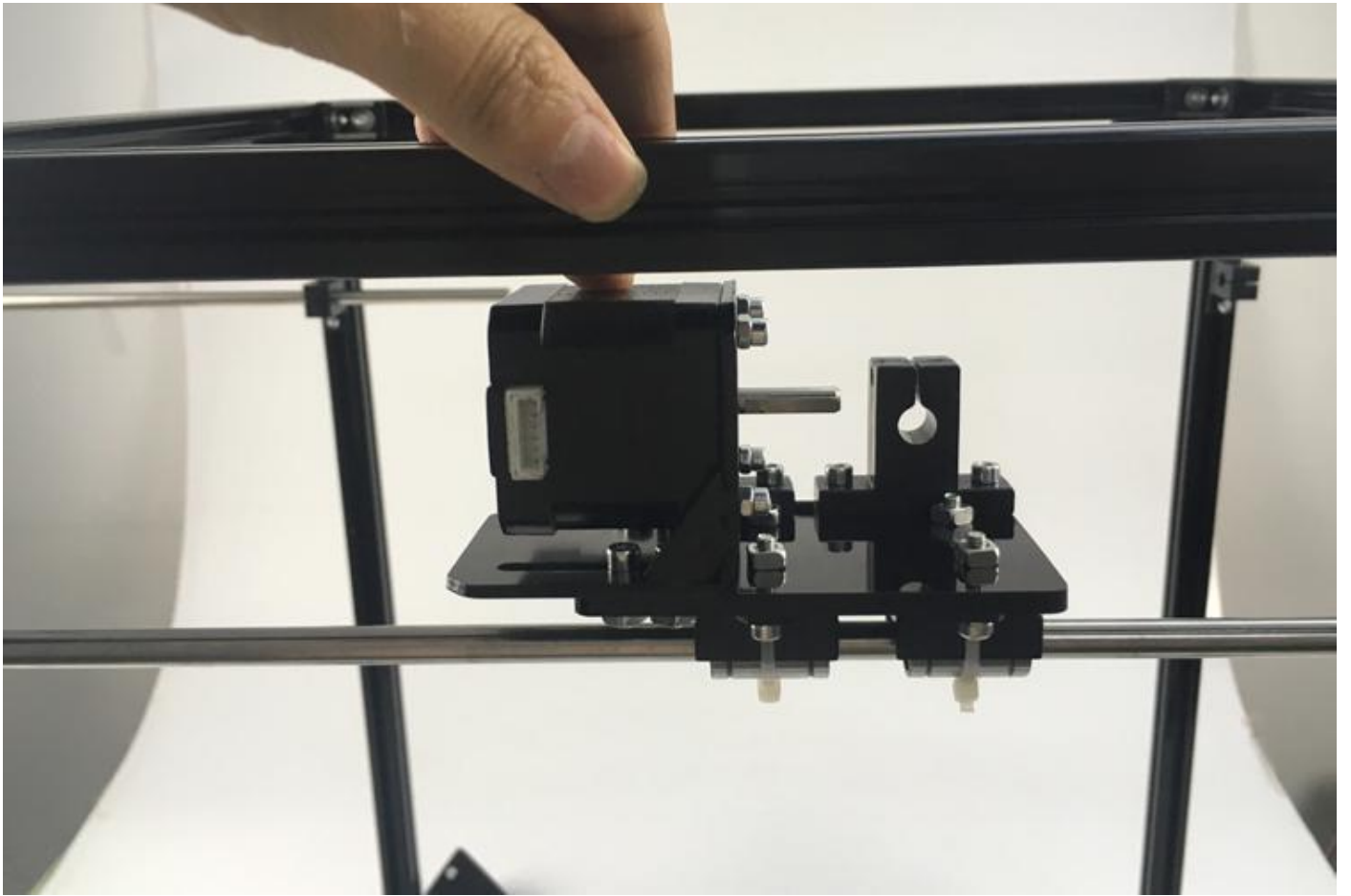

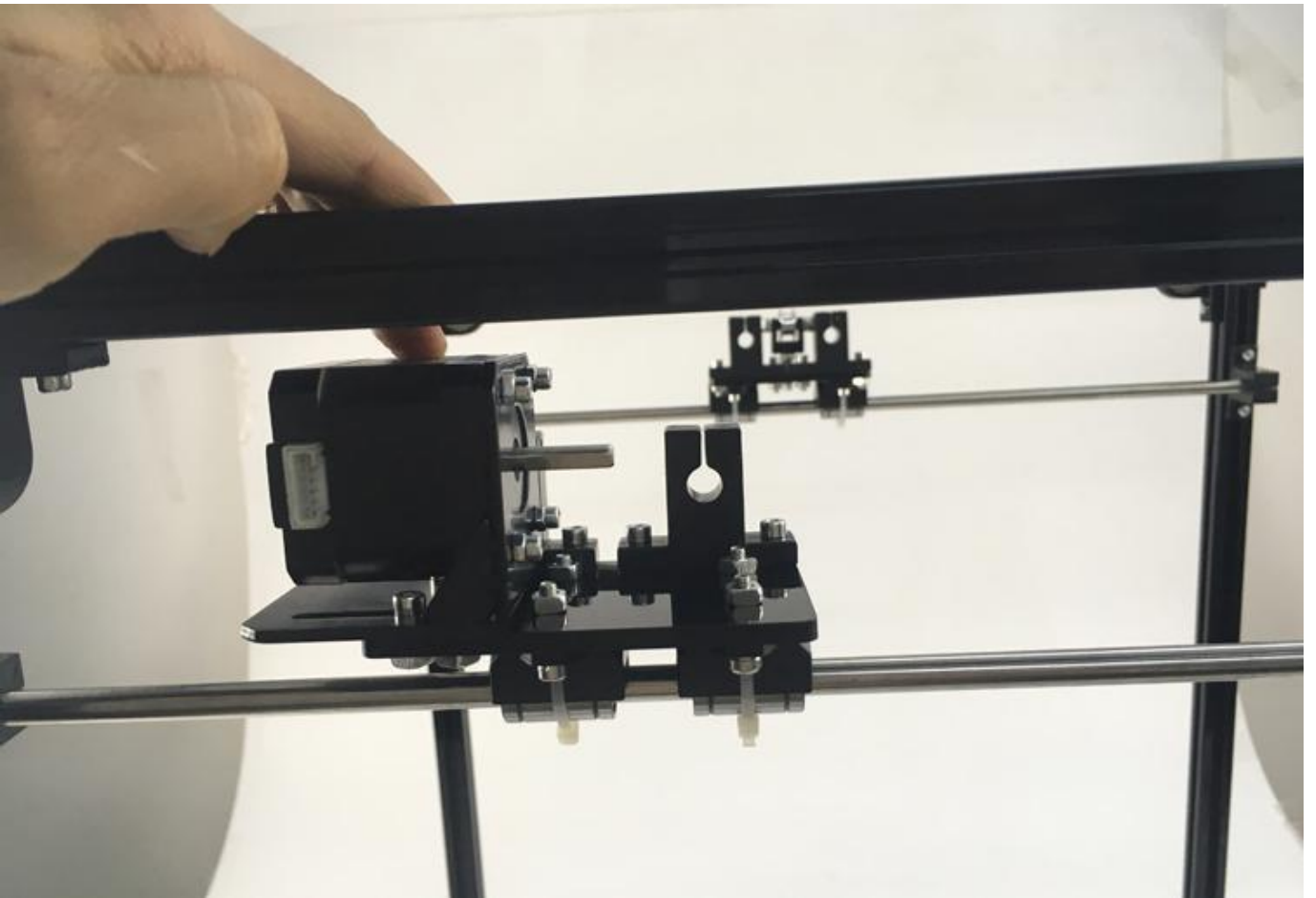
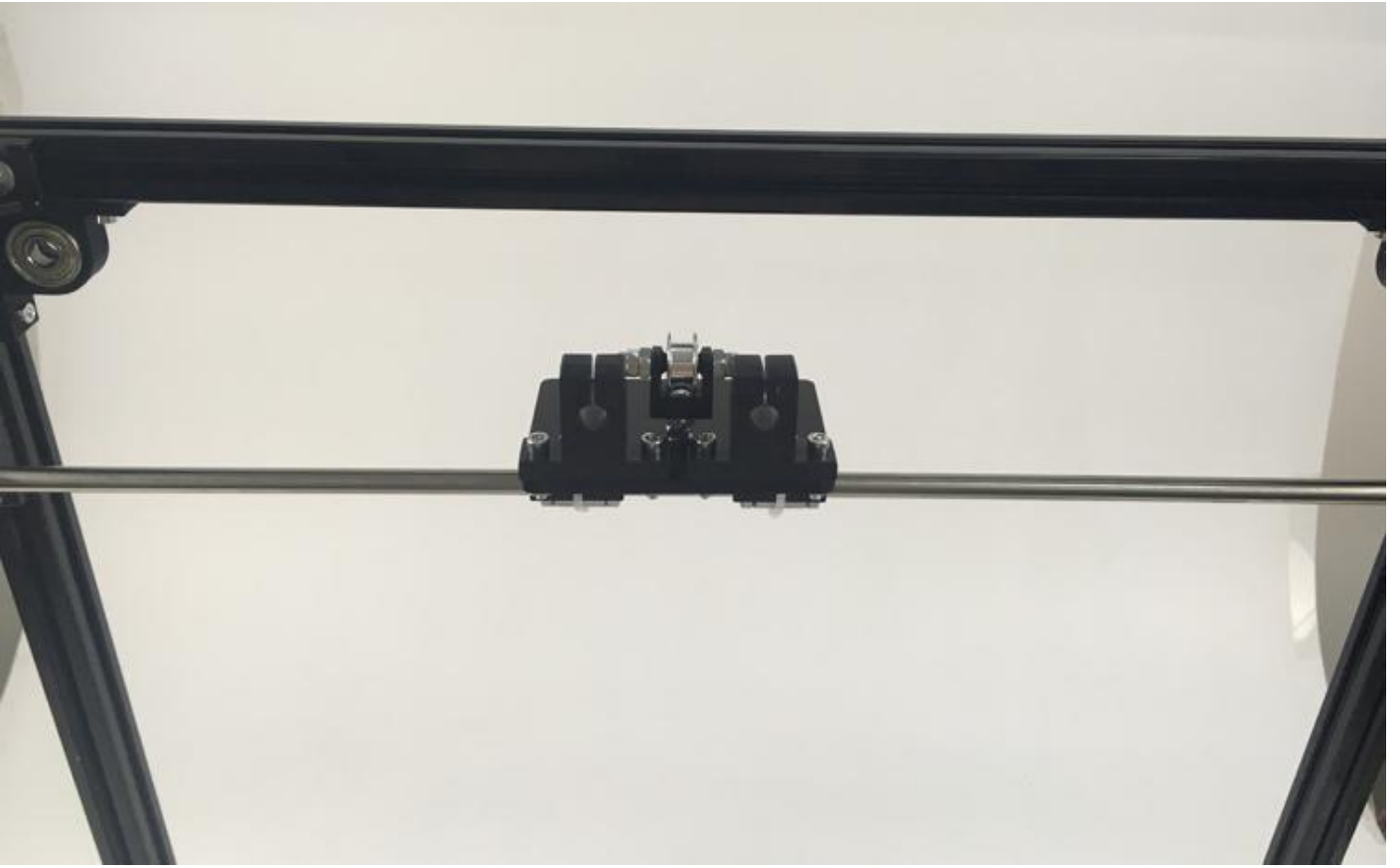



these rod maybe not absolute 400mm, maybe  $400\text{mm} \pm 5\text{mm}$ ,  
it's no problem and no matter.

for these two rods,400mm is enough long.

400 mm rod



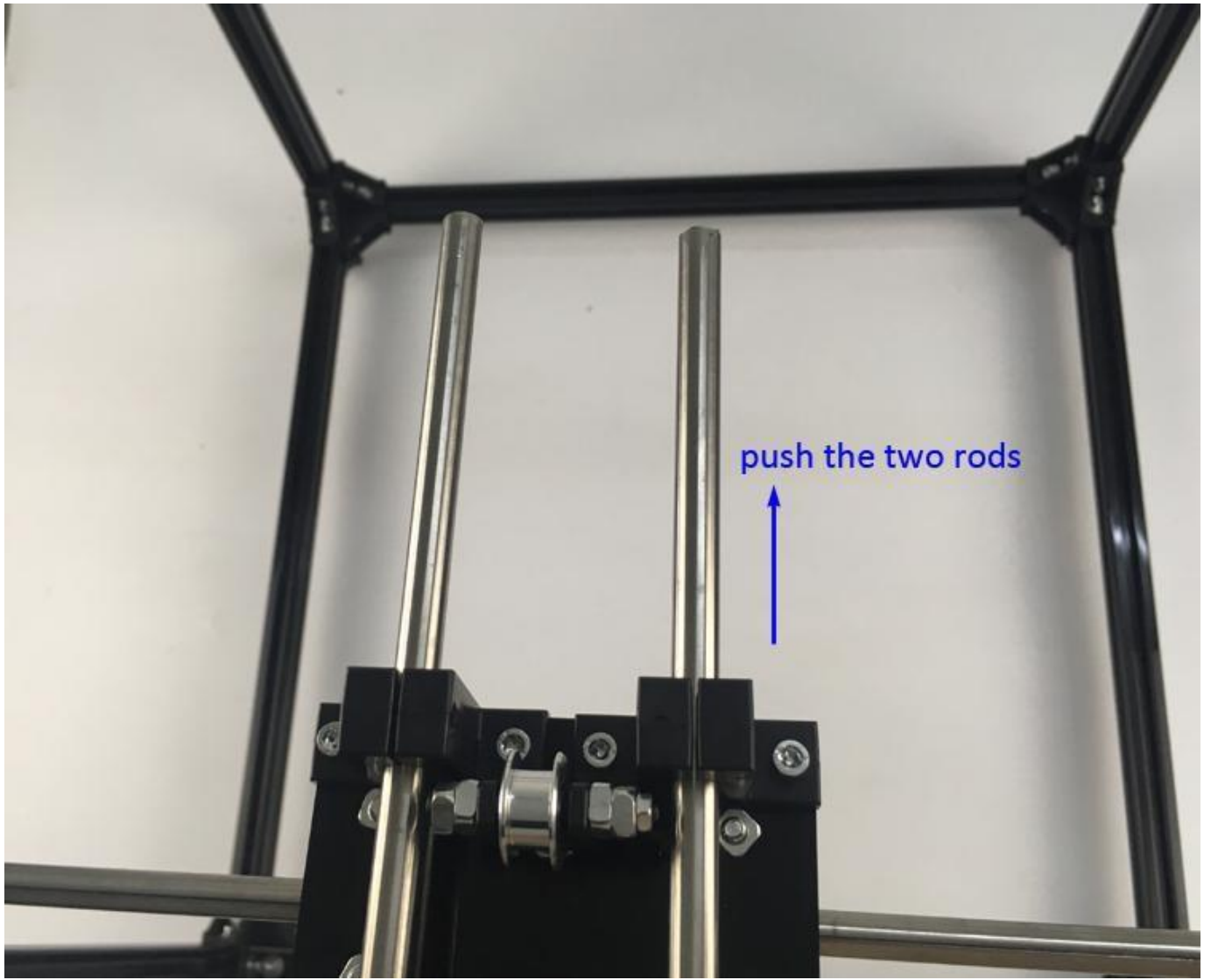



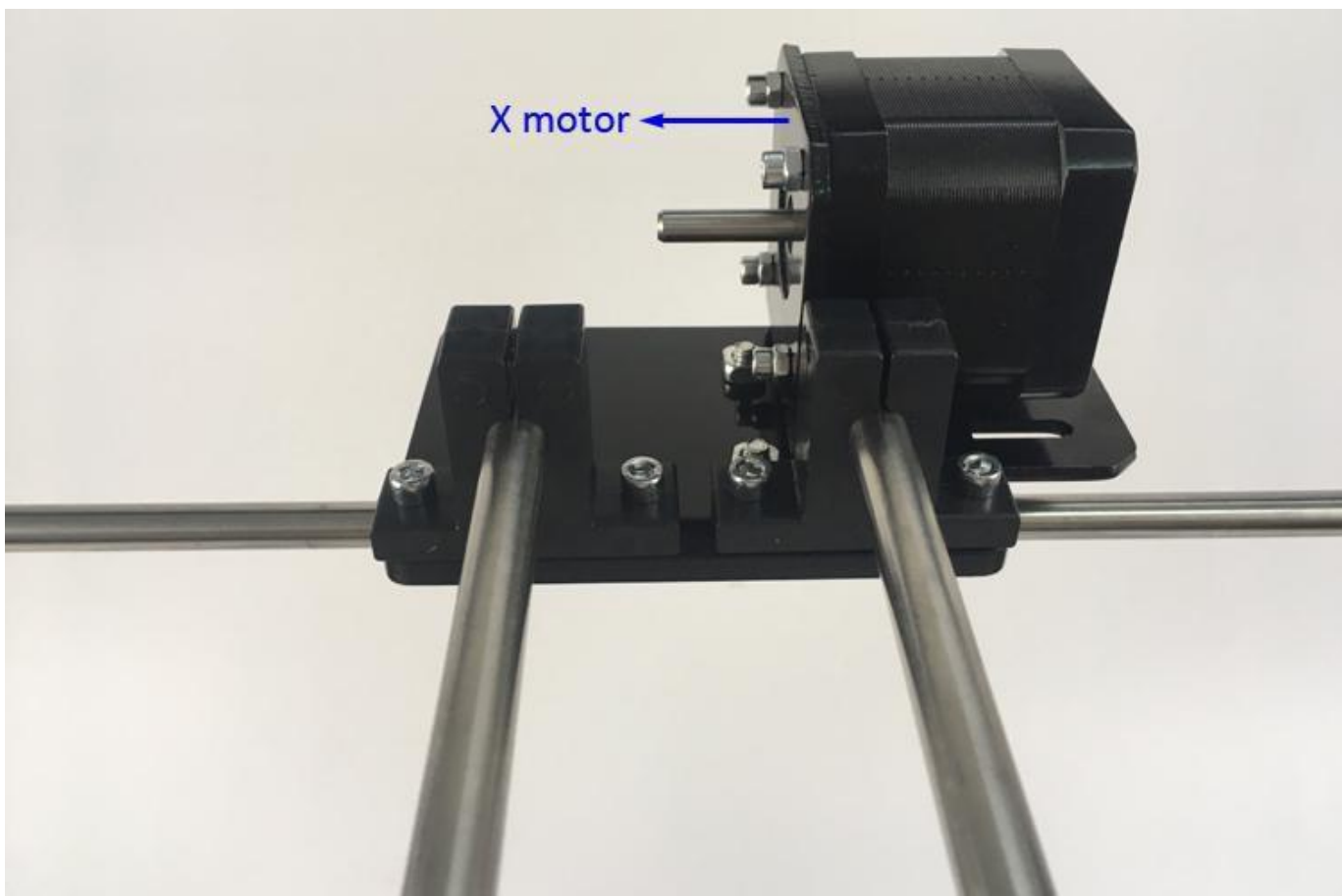
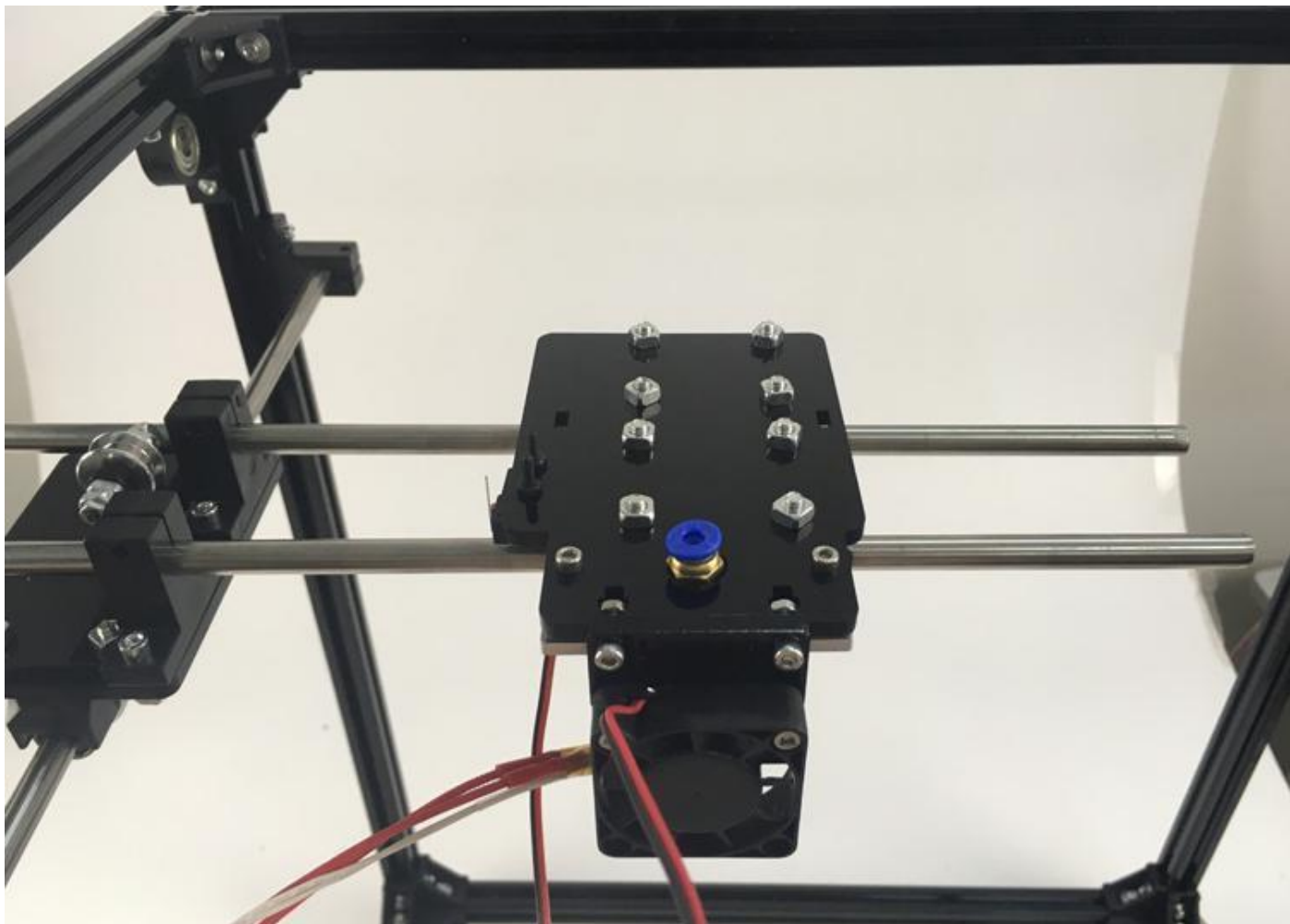

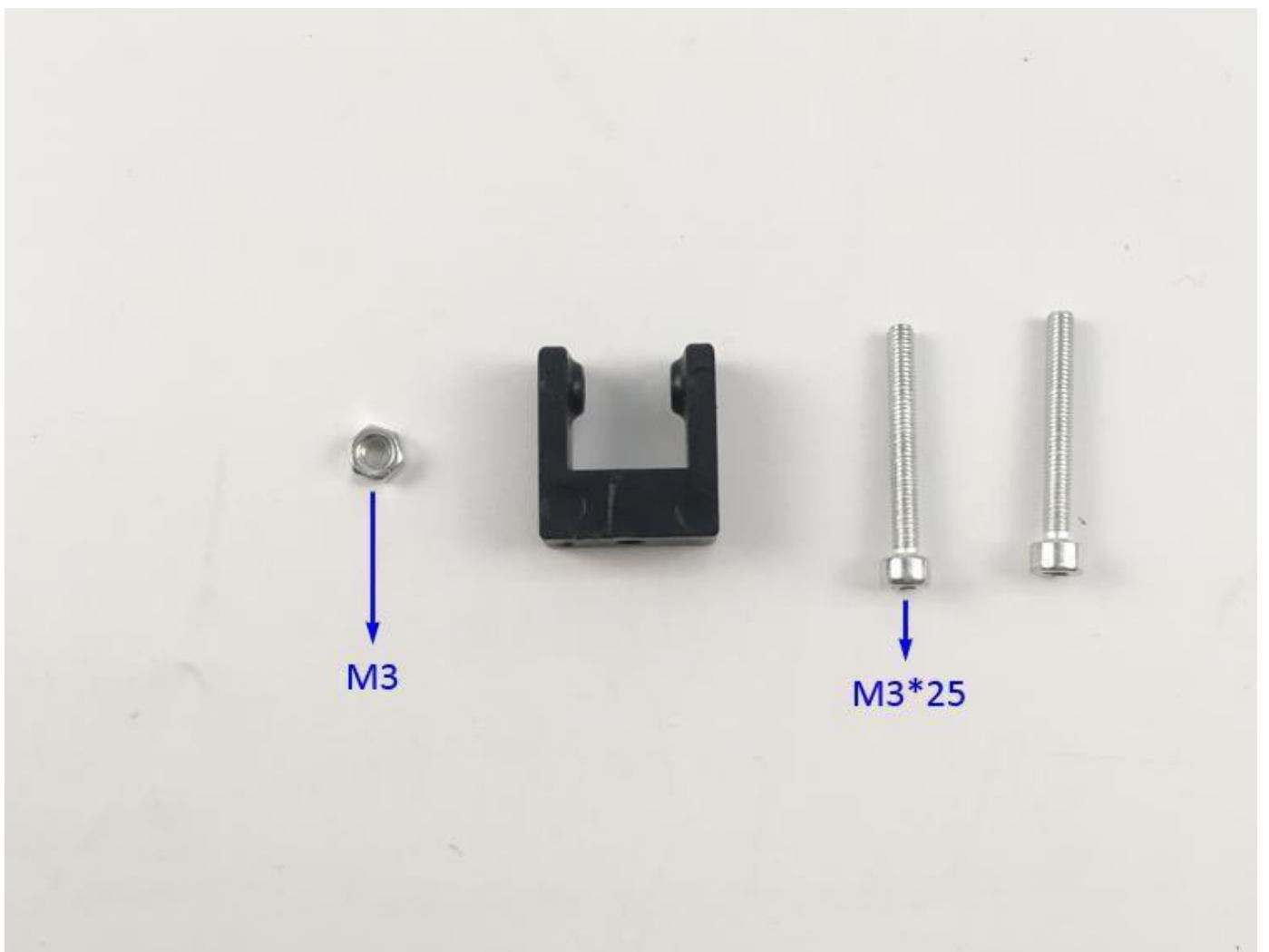
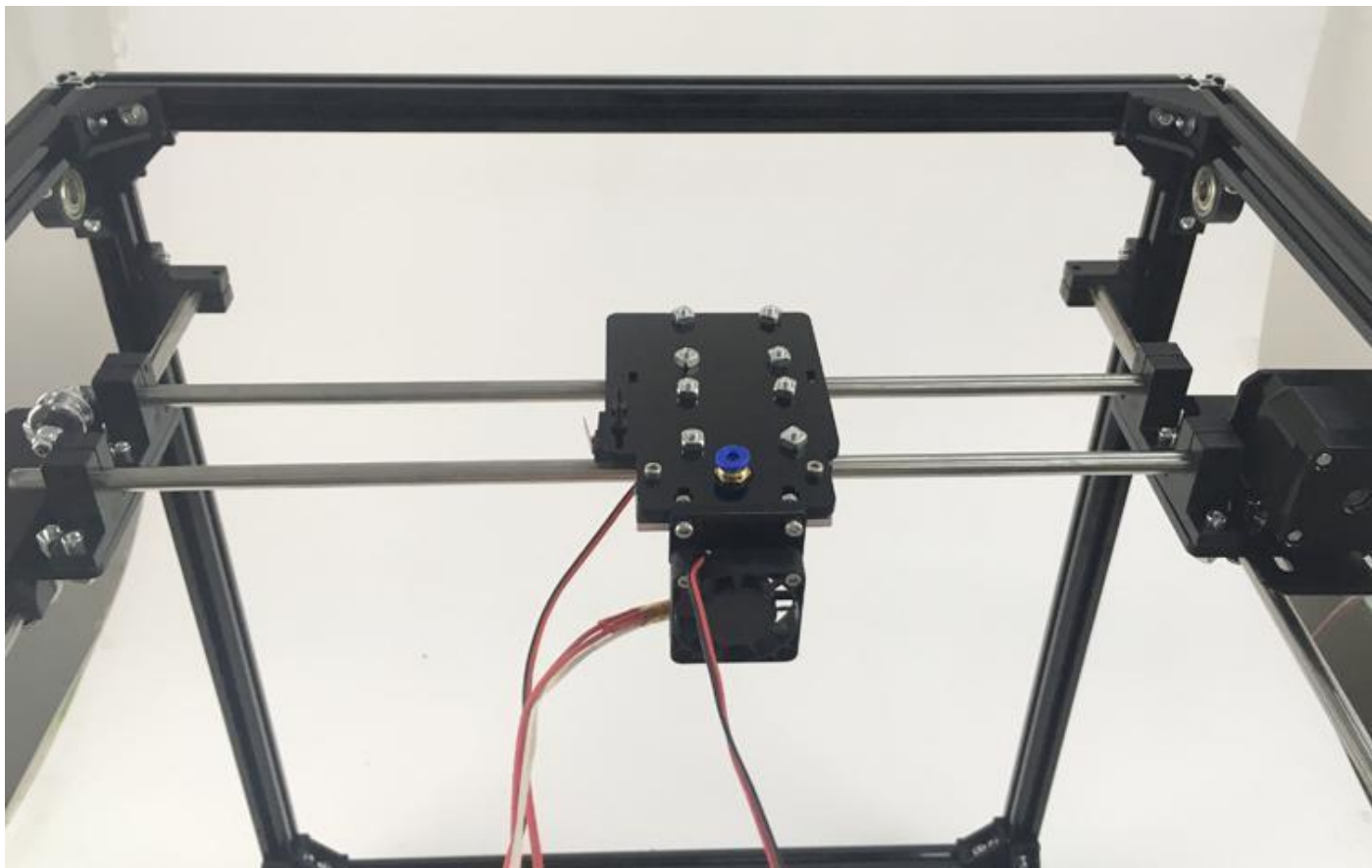

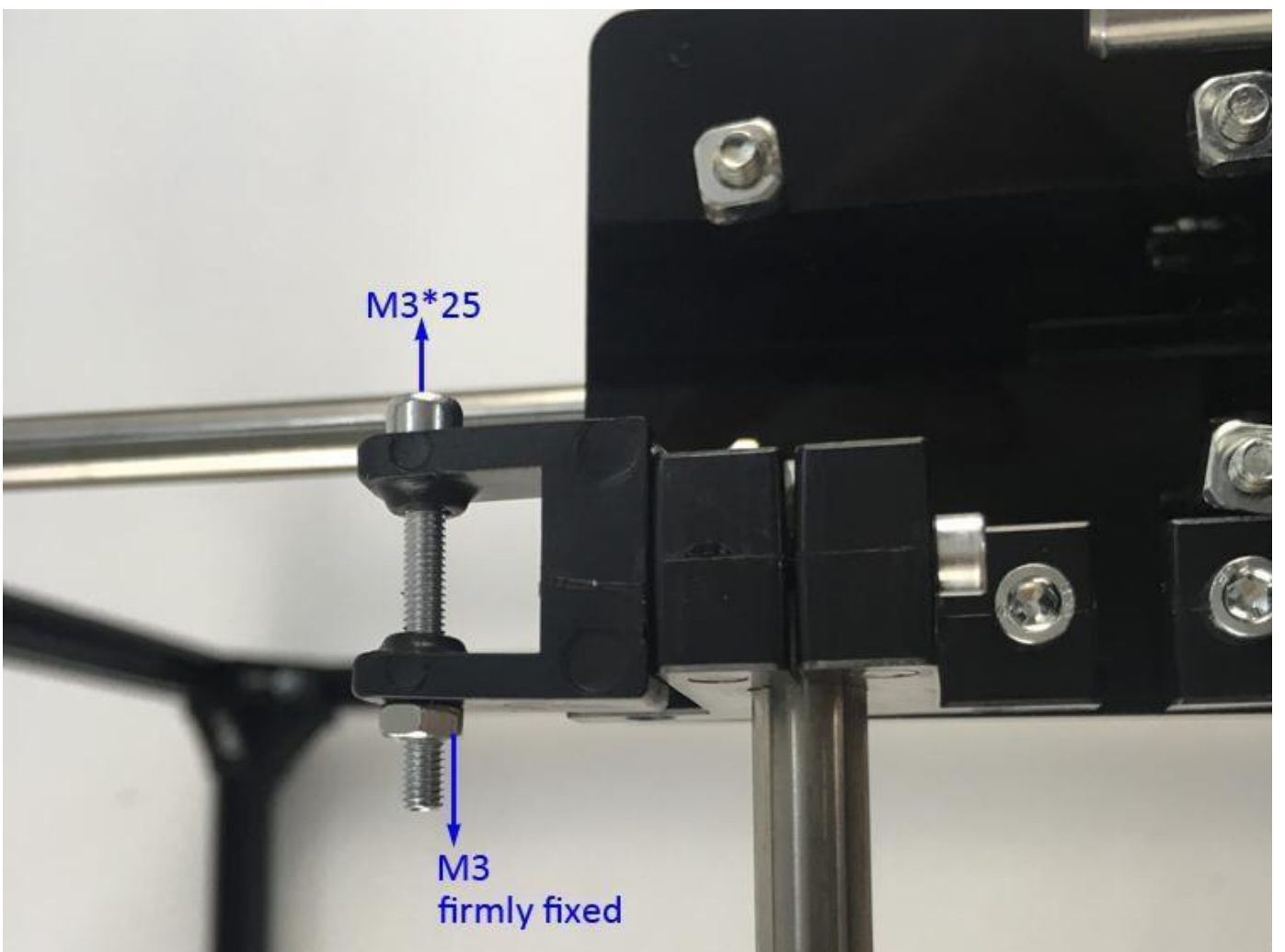
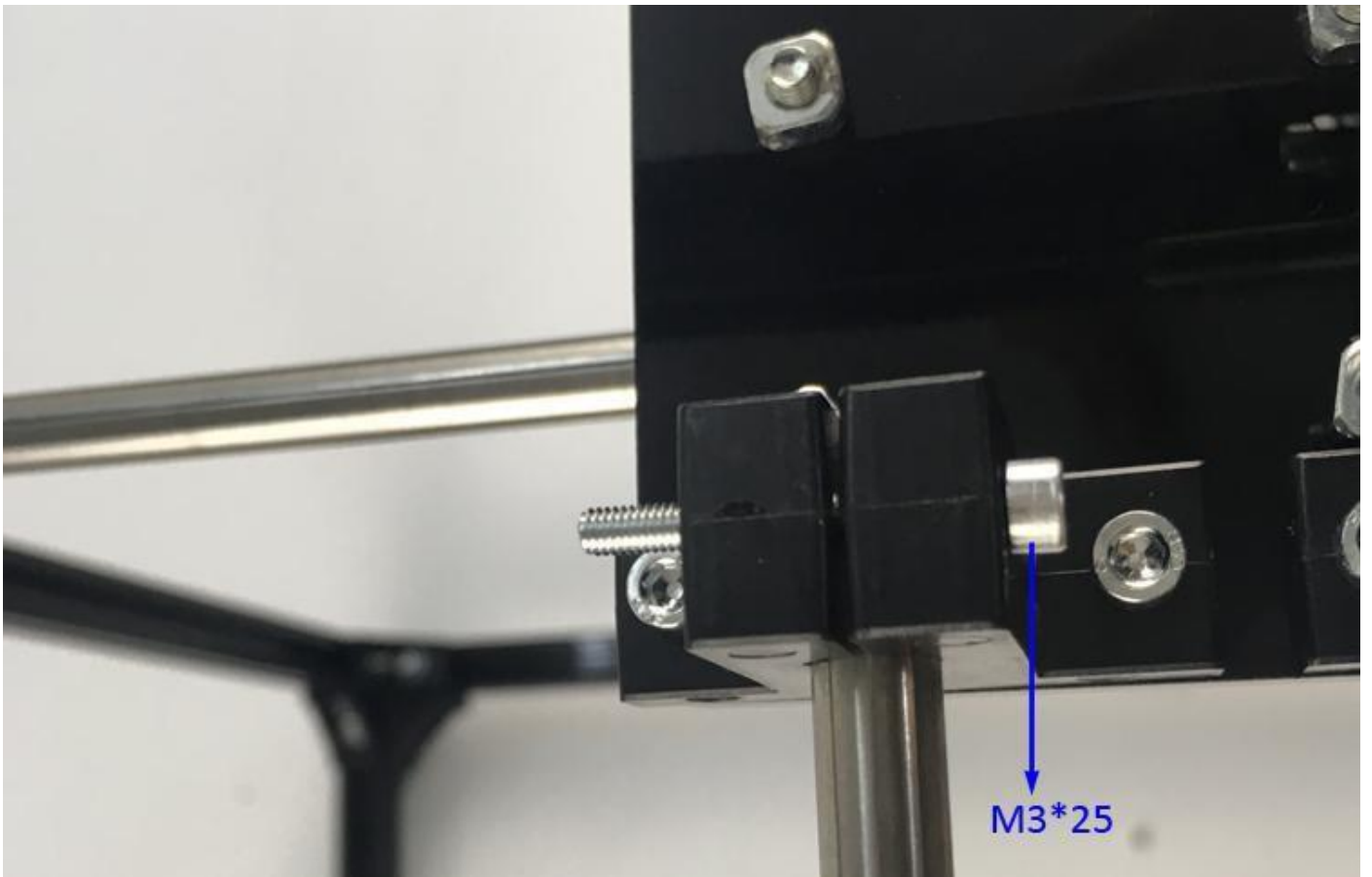

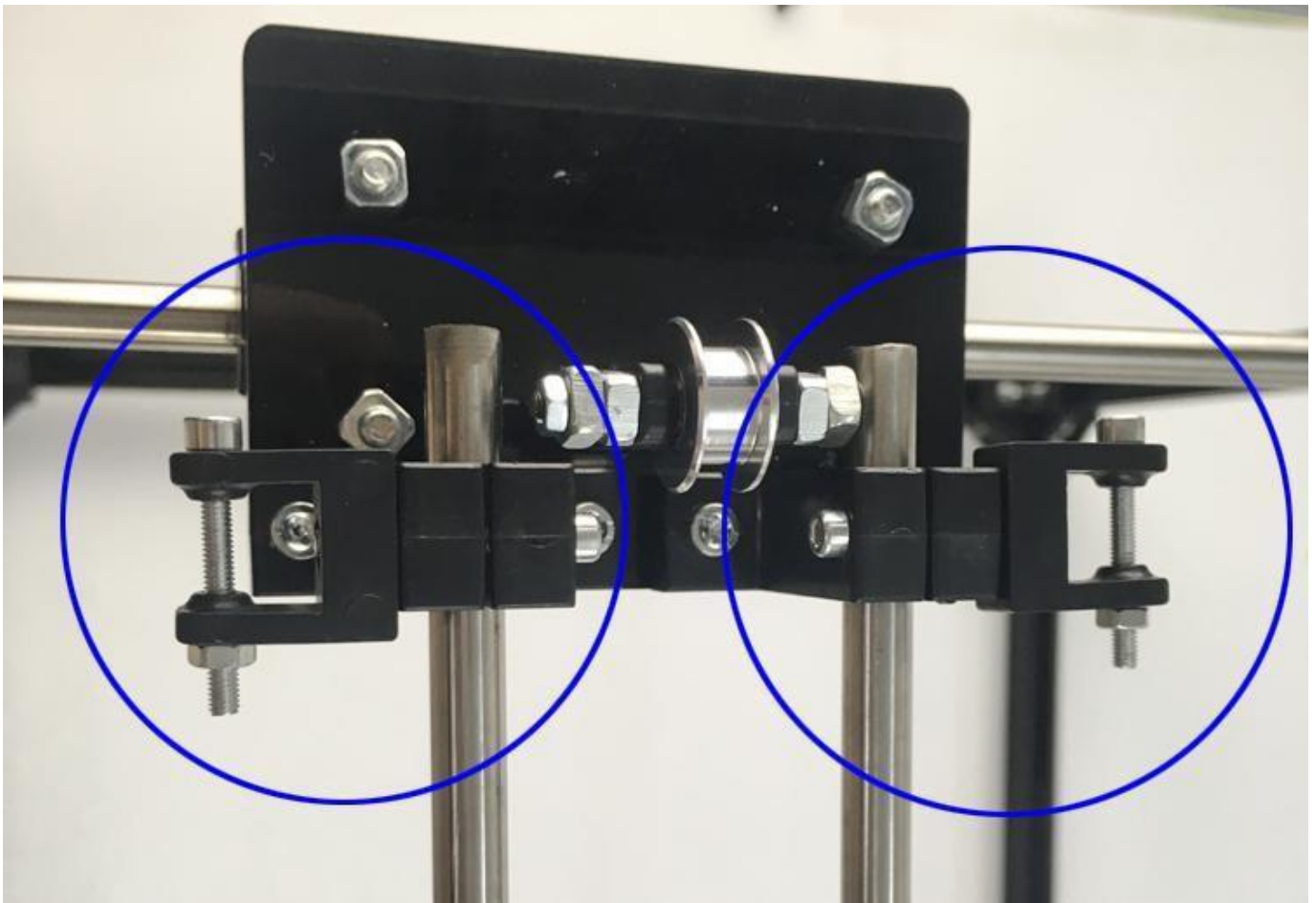
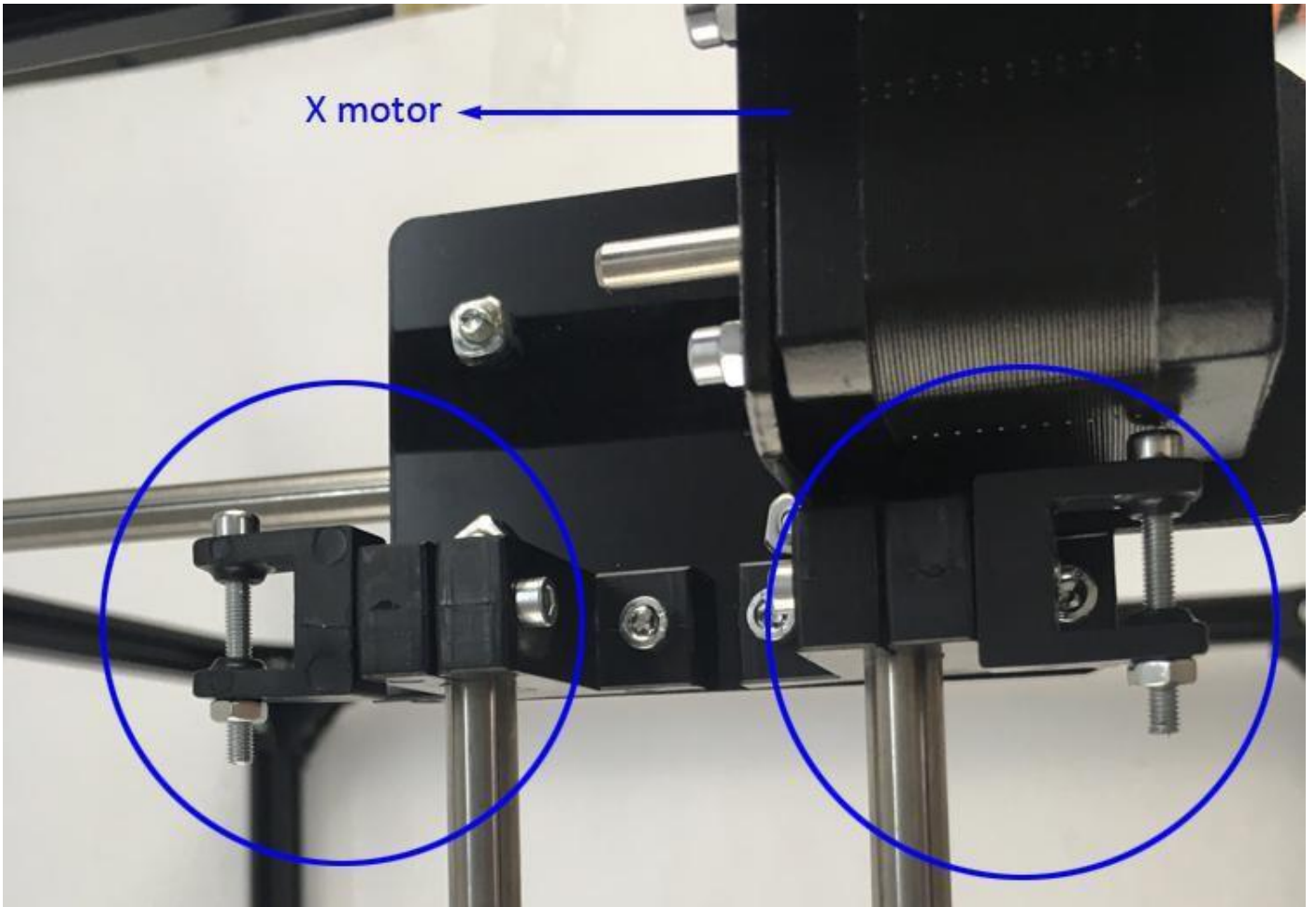

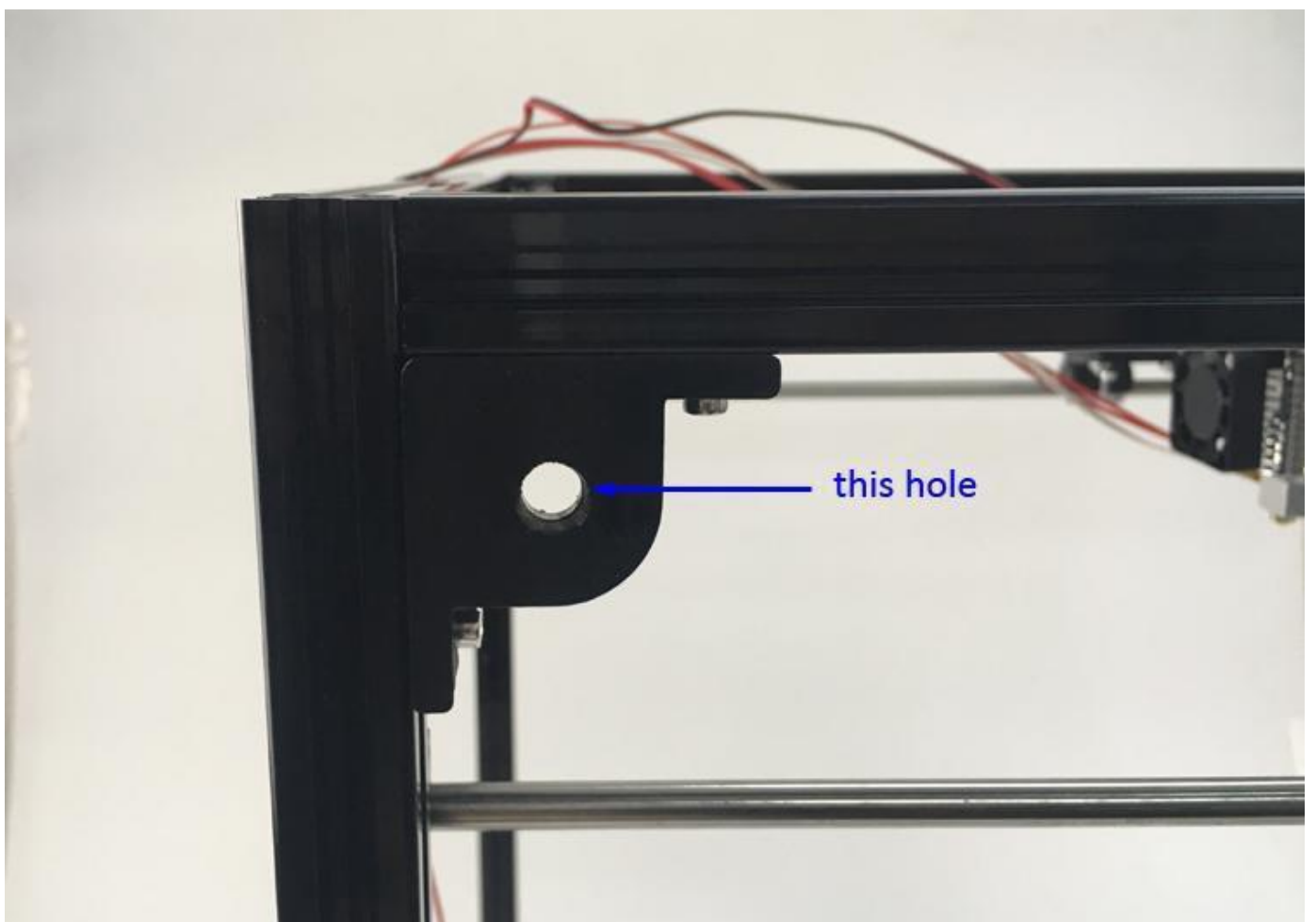
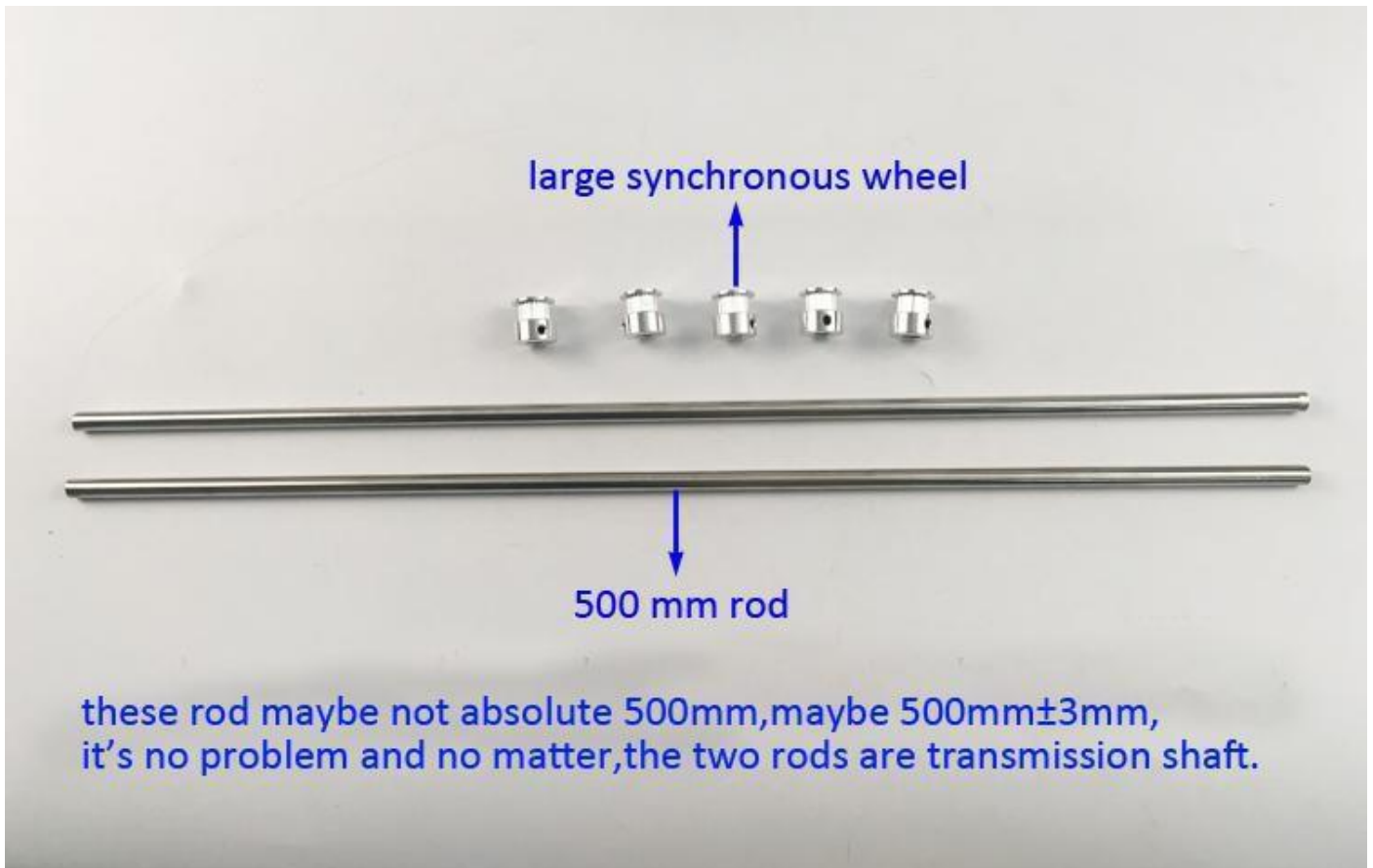

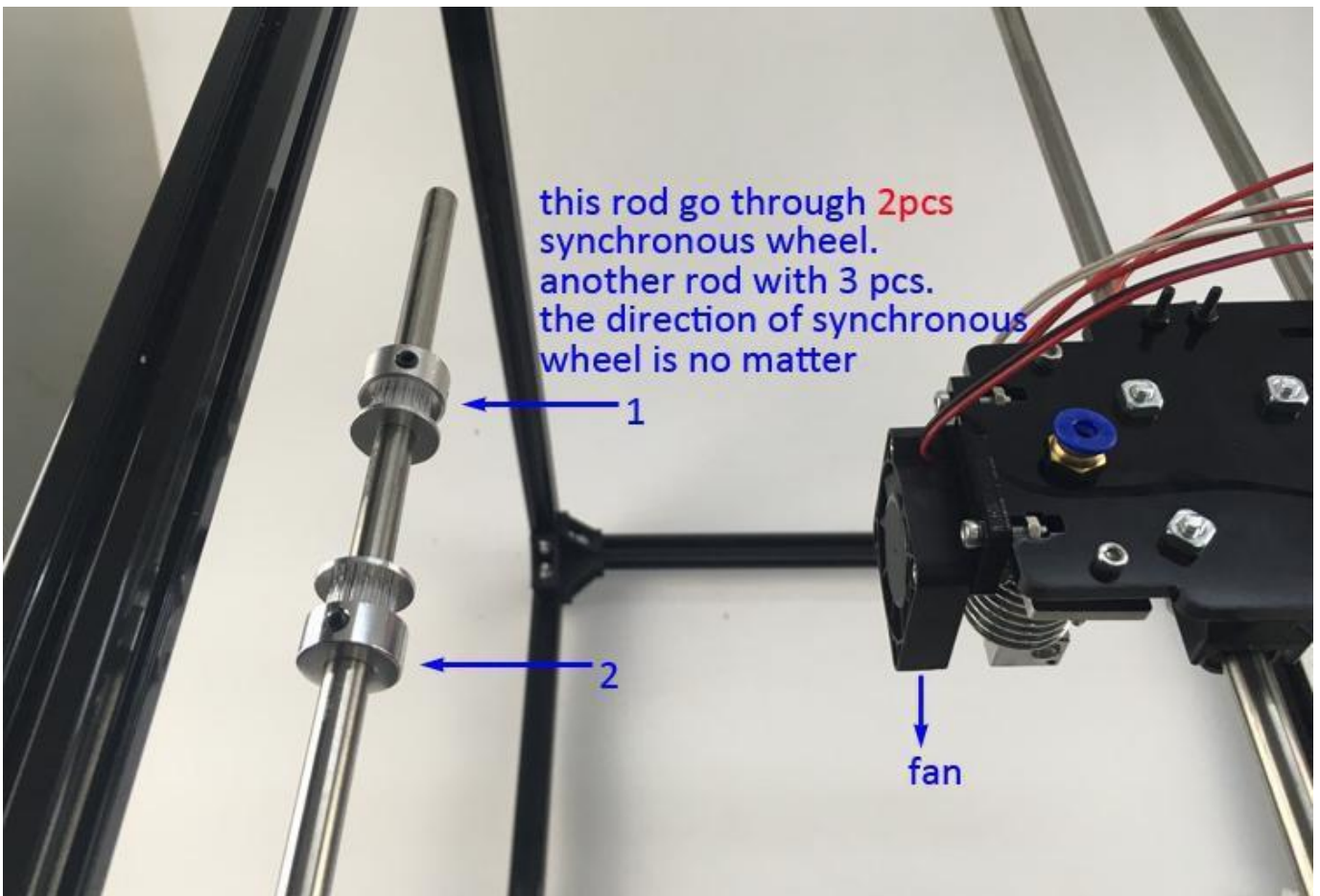
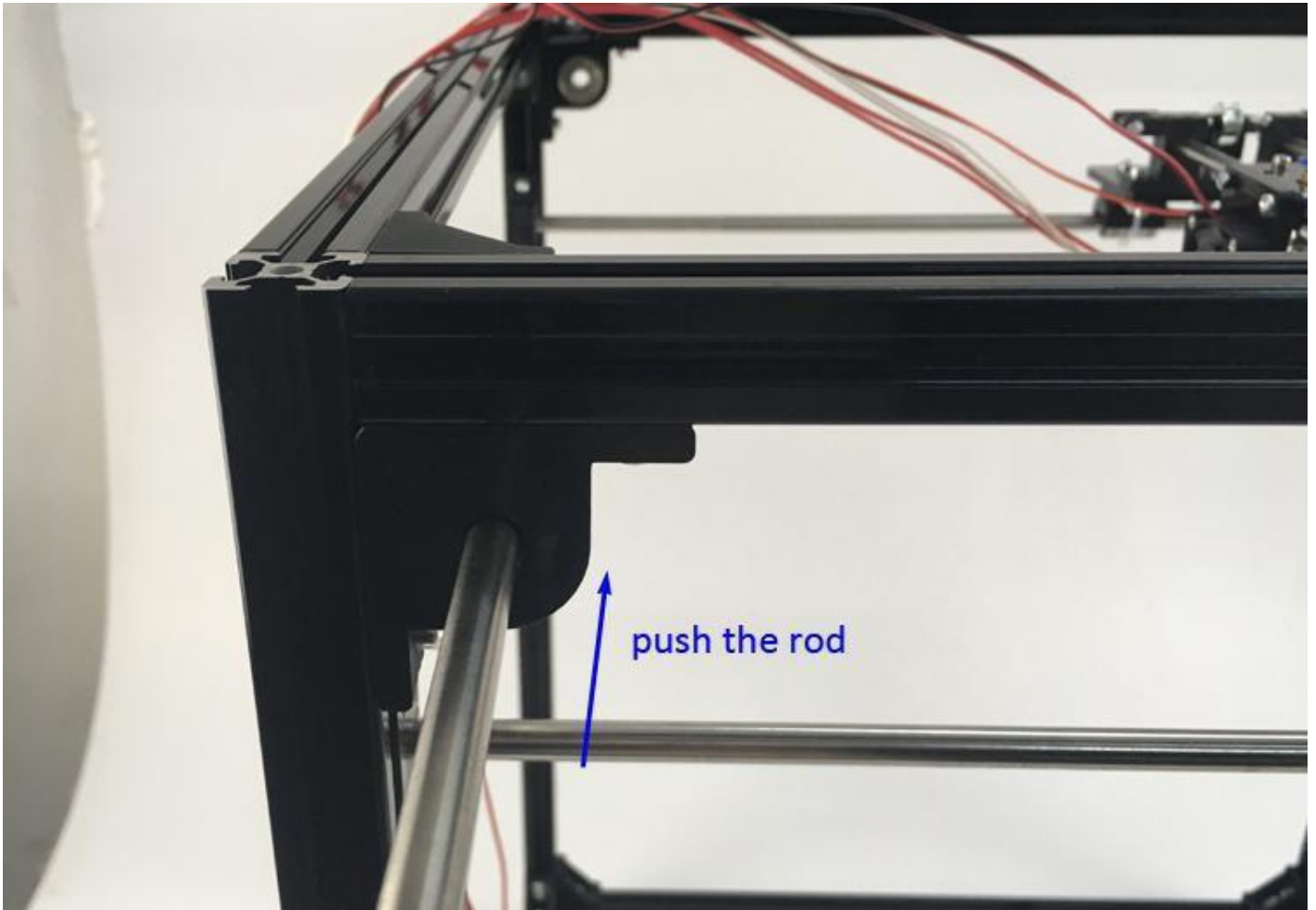

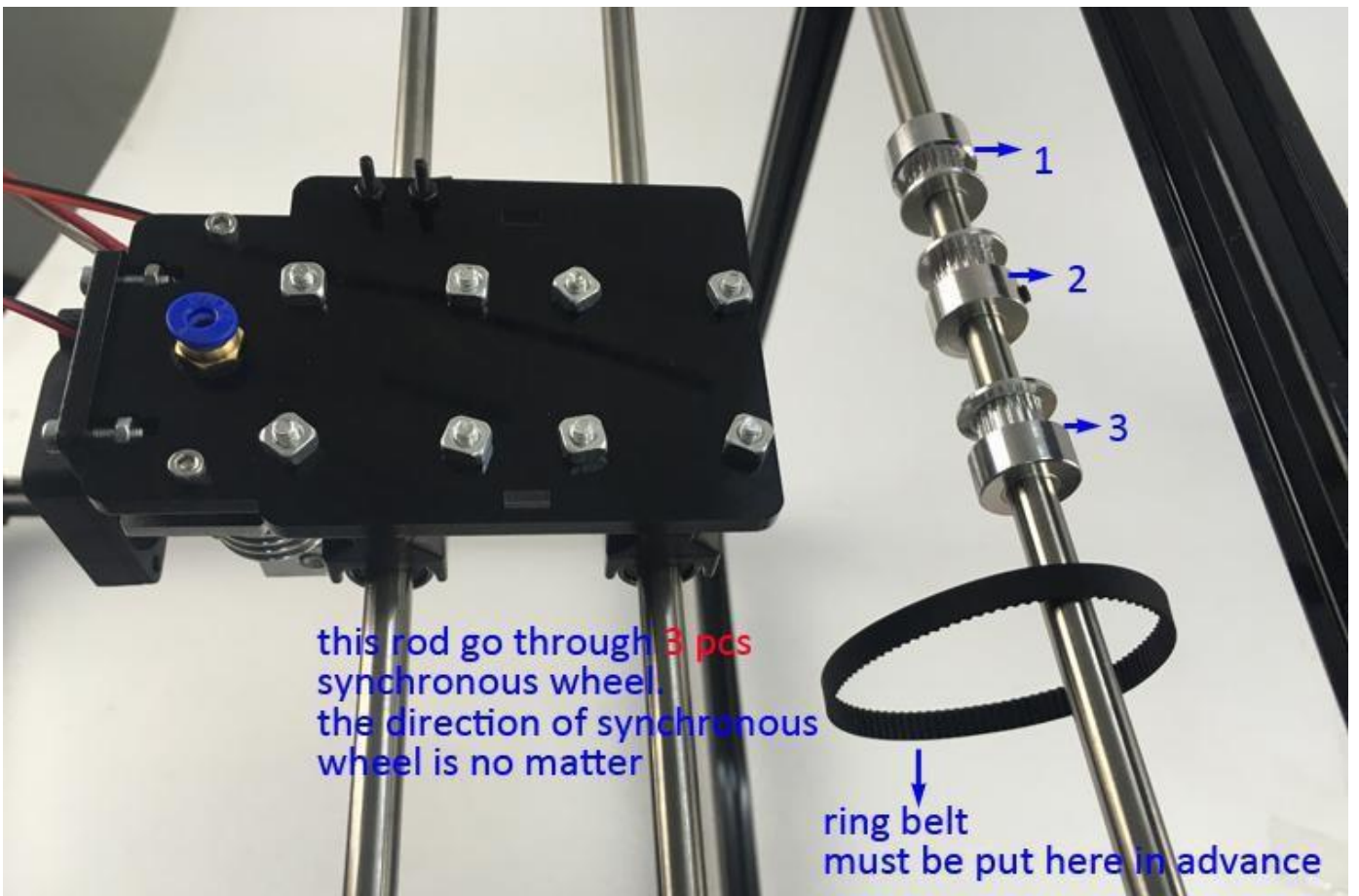
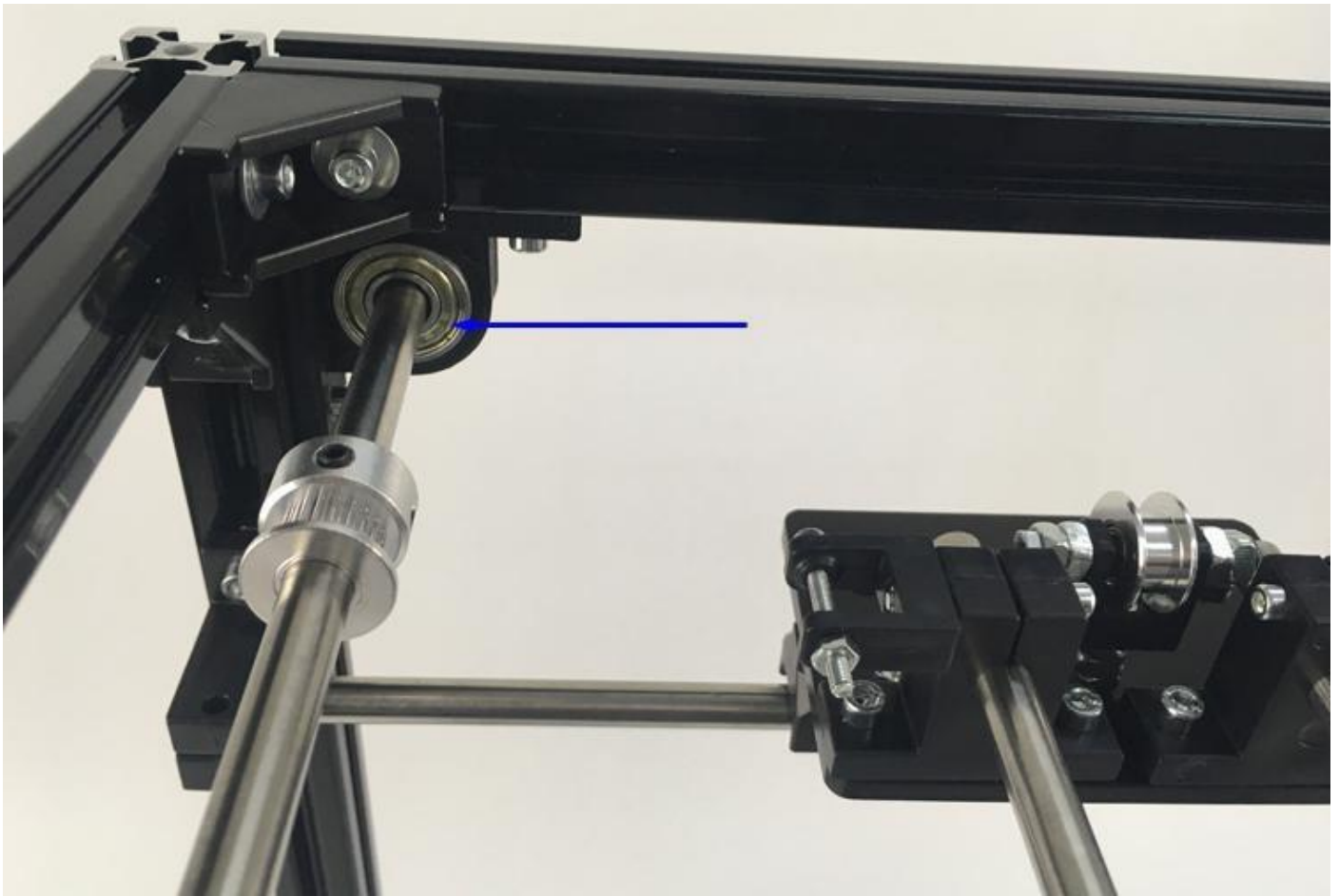

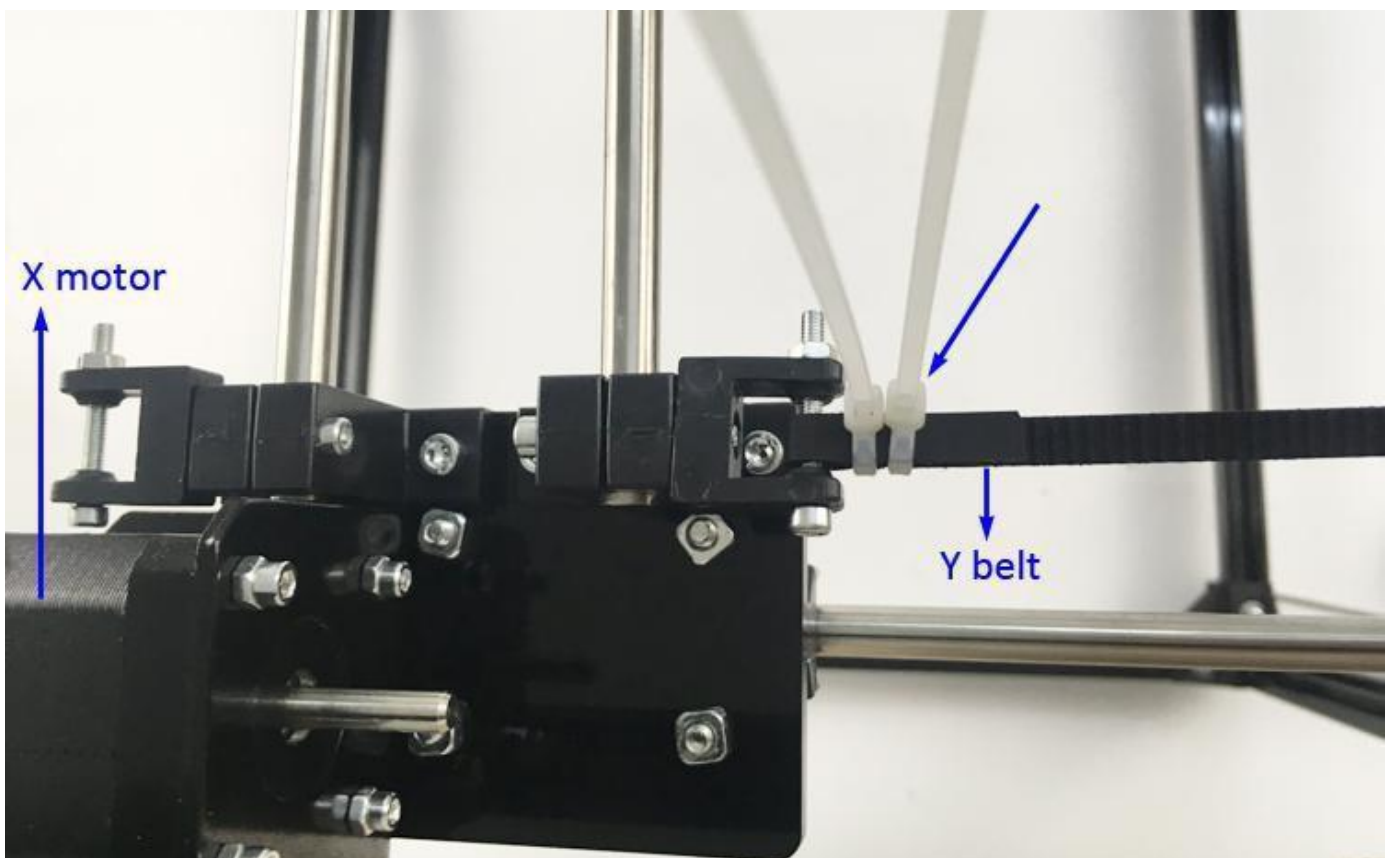
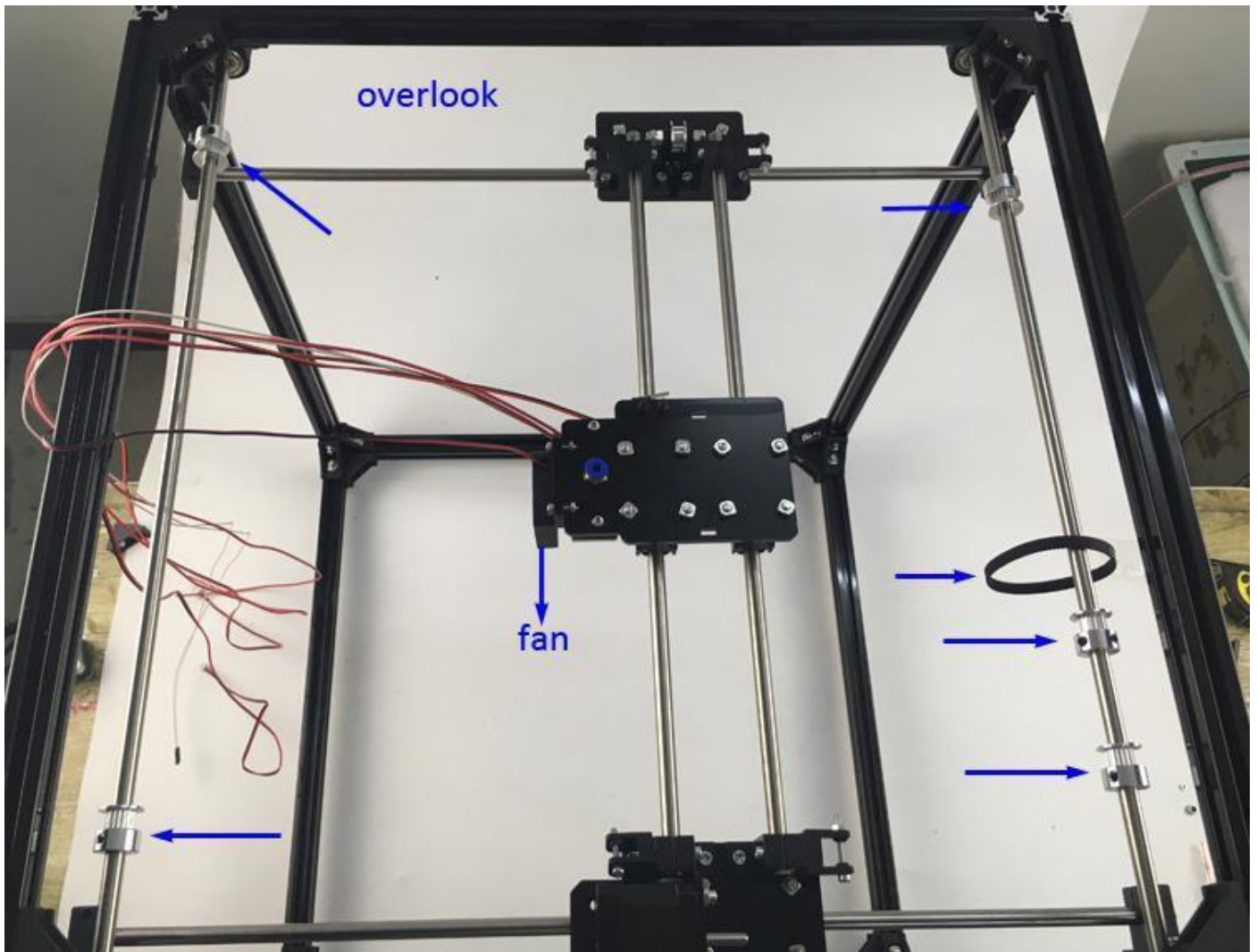



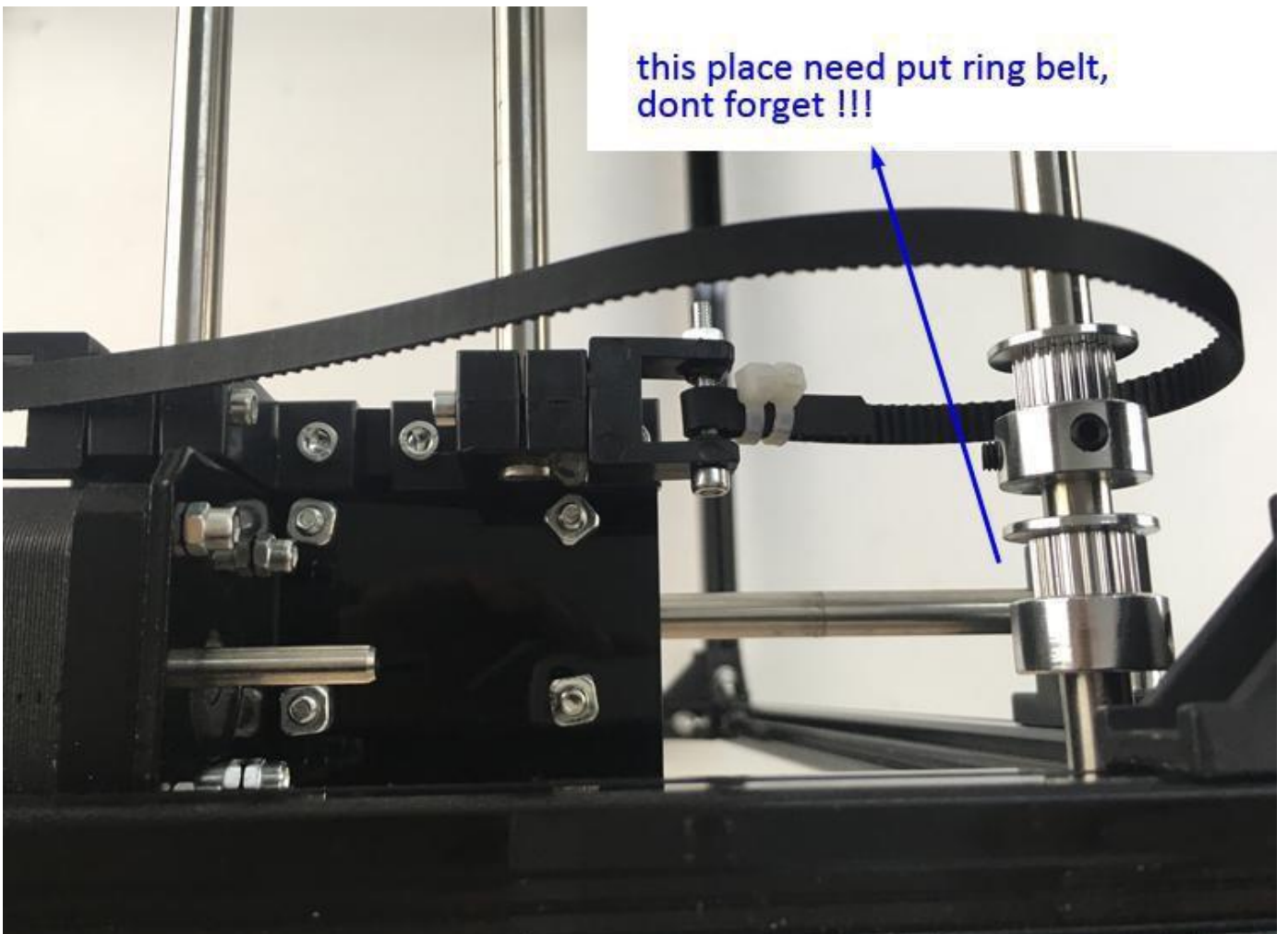
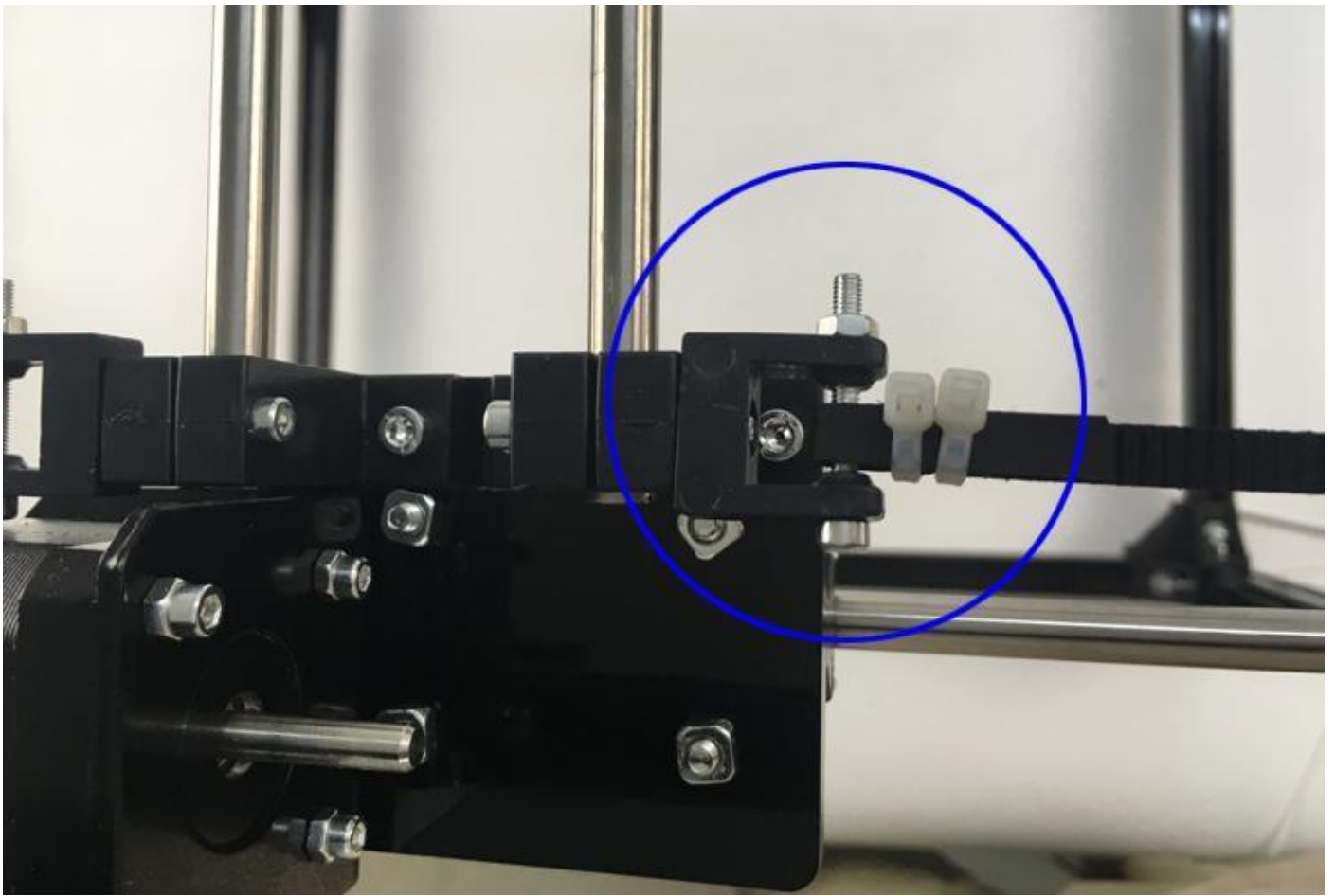

this is ring belt, put here, this is right.  
no forget!!!

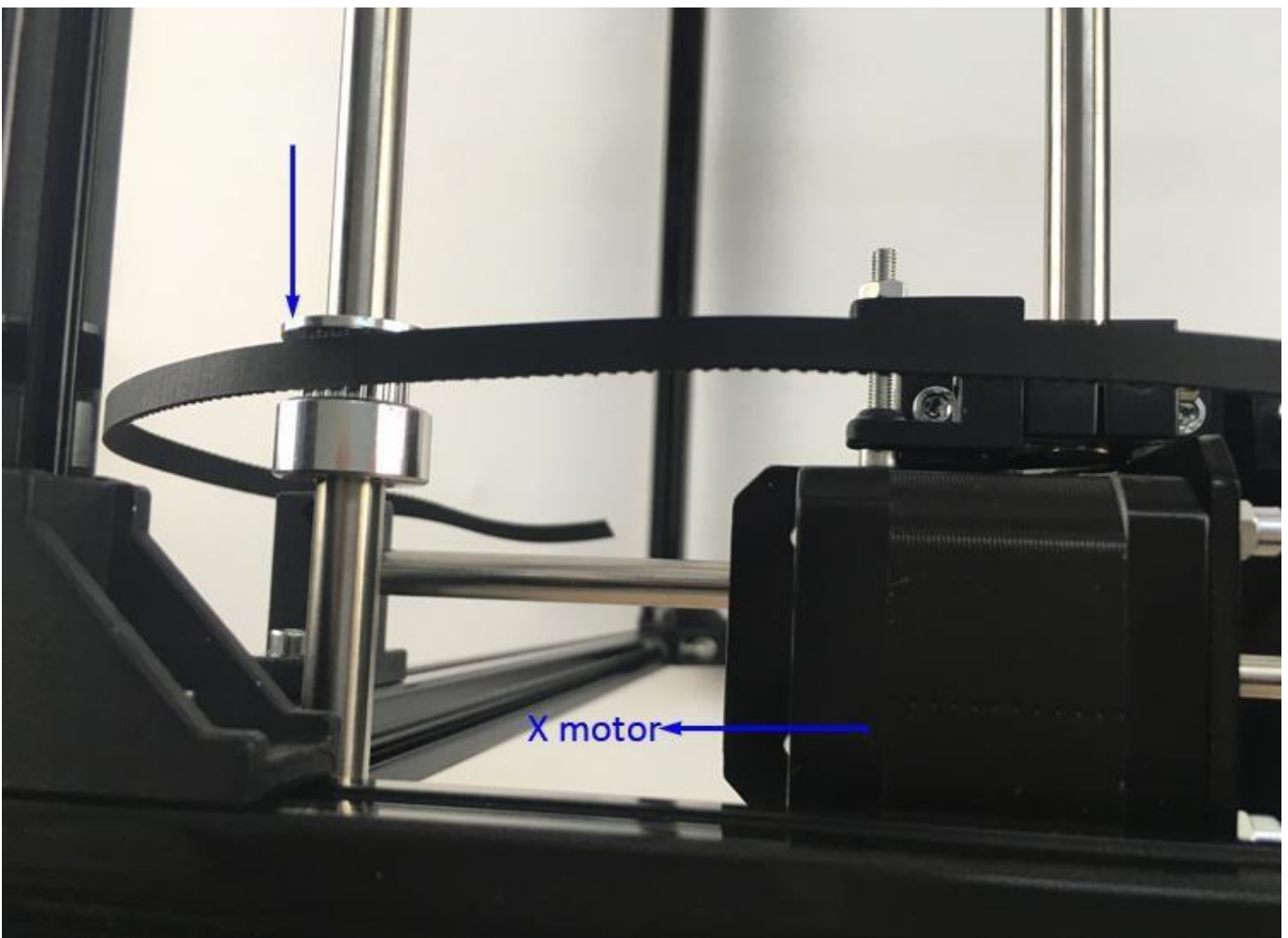
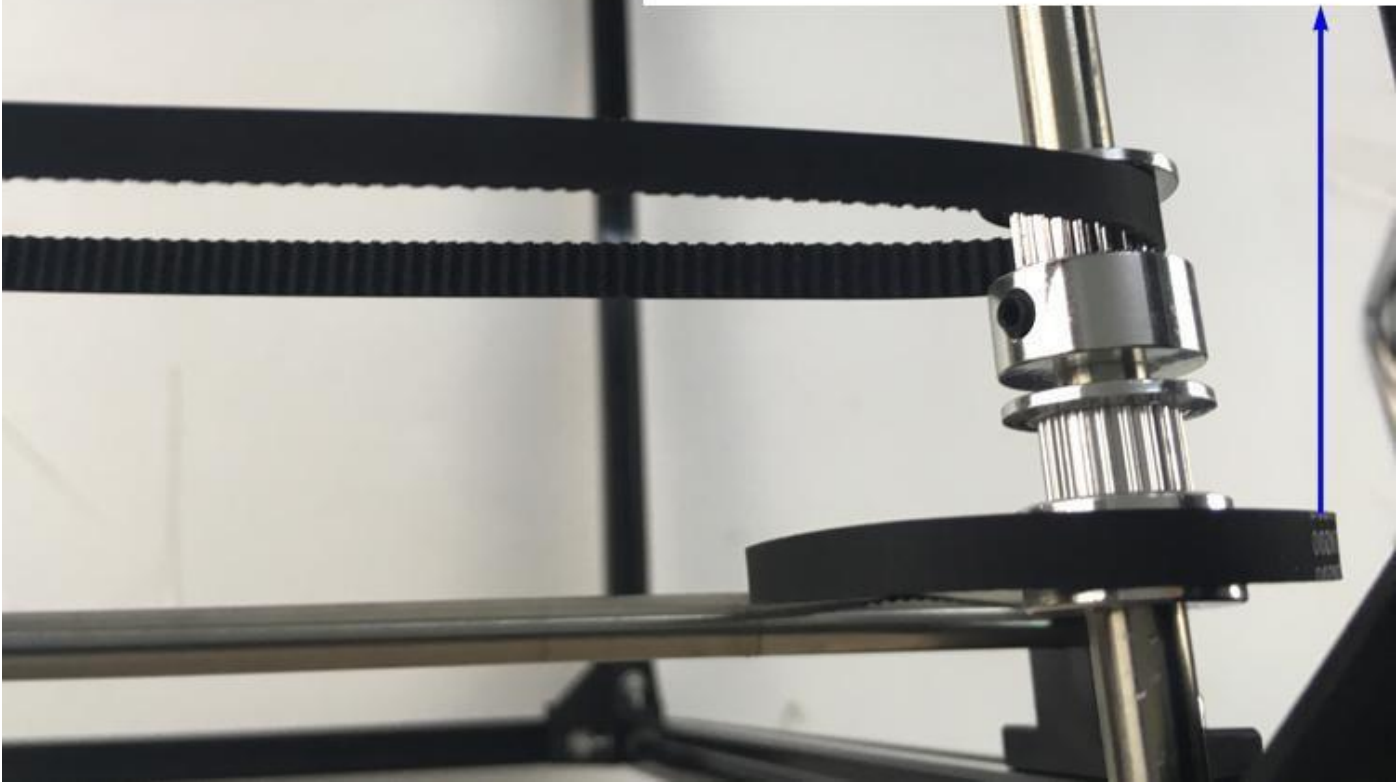

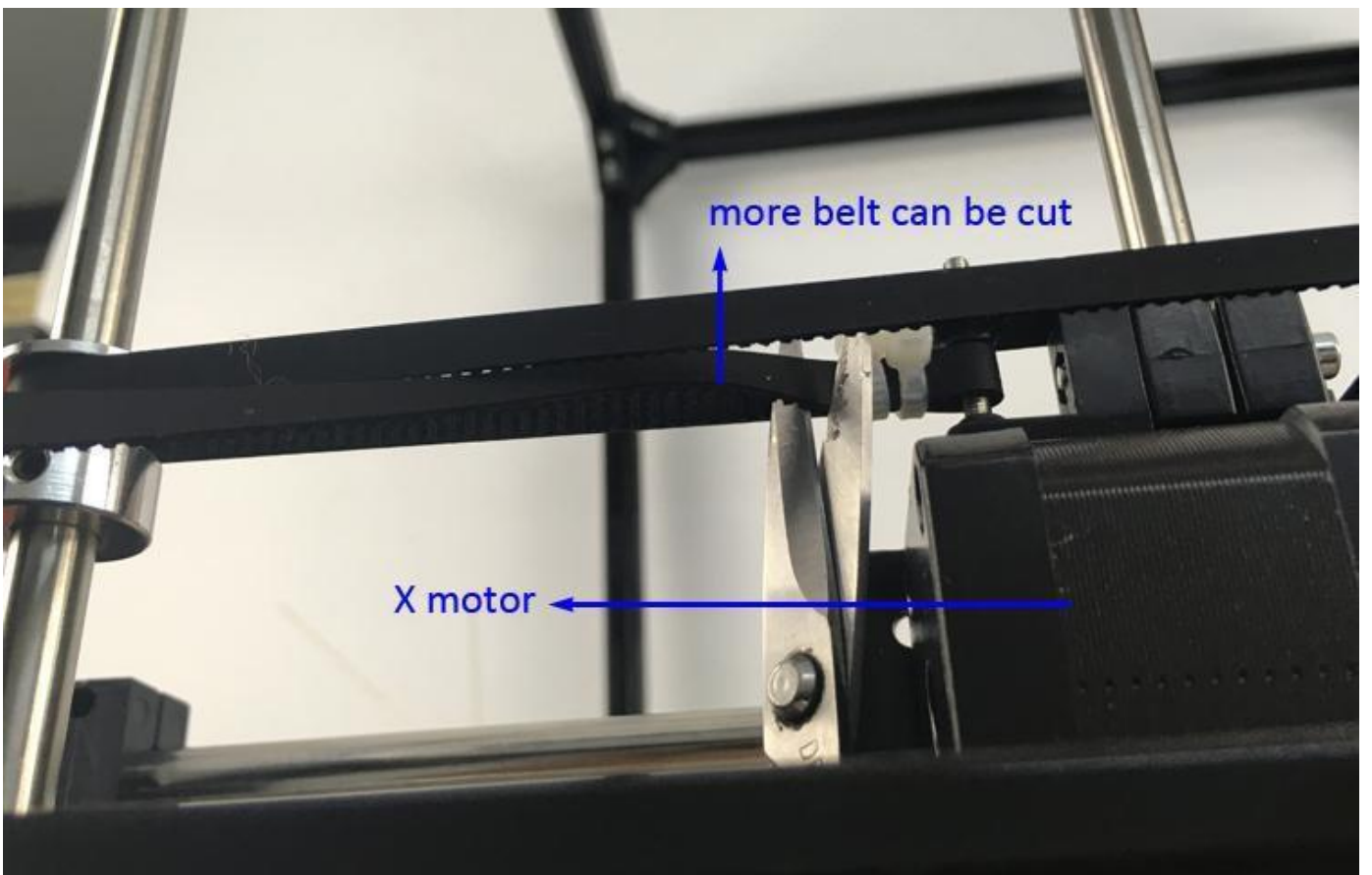
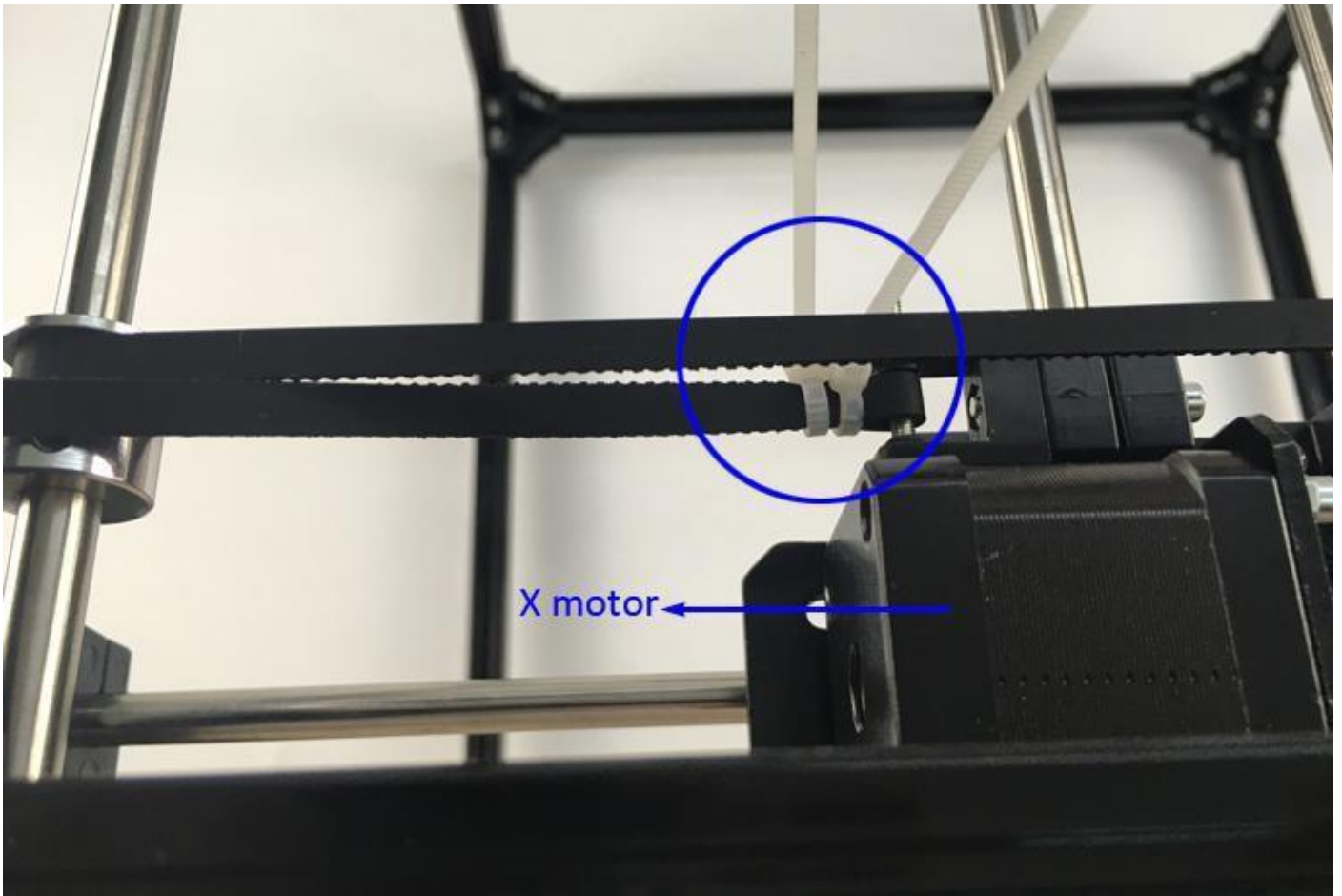

1,2,3,4 point, the belt need be align and in one same straight line

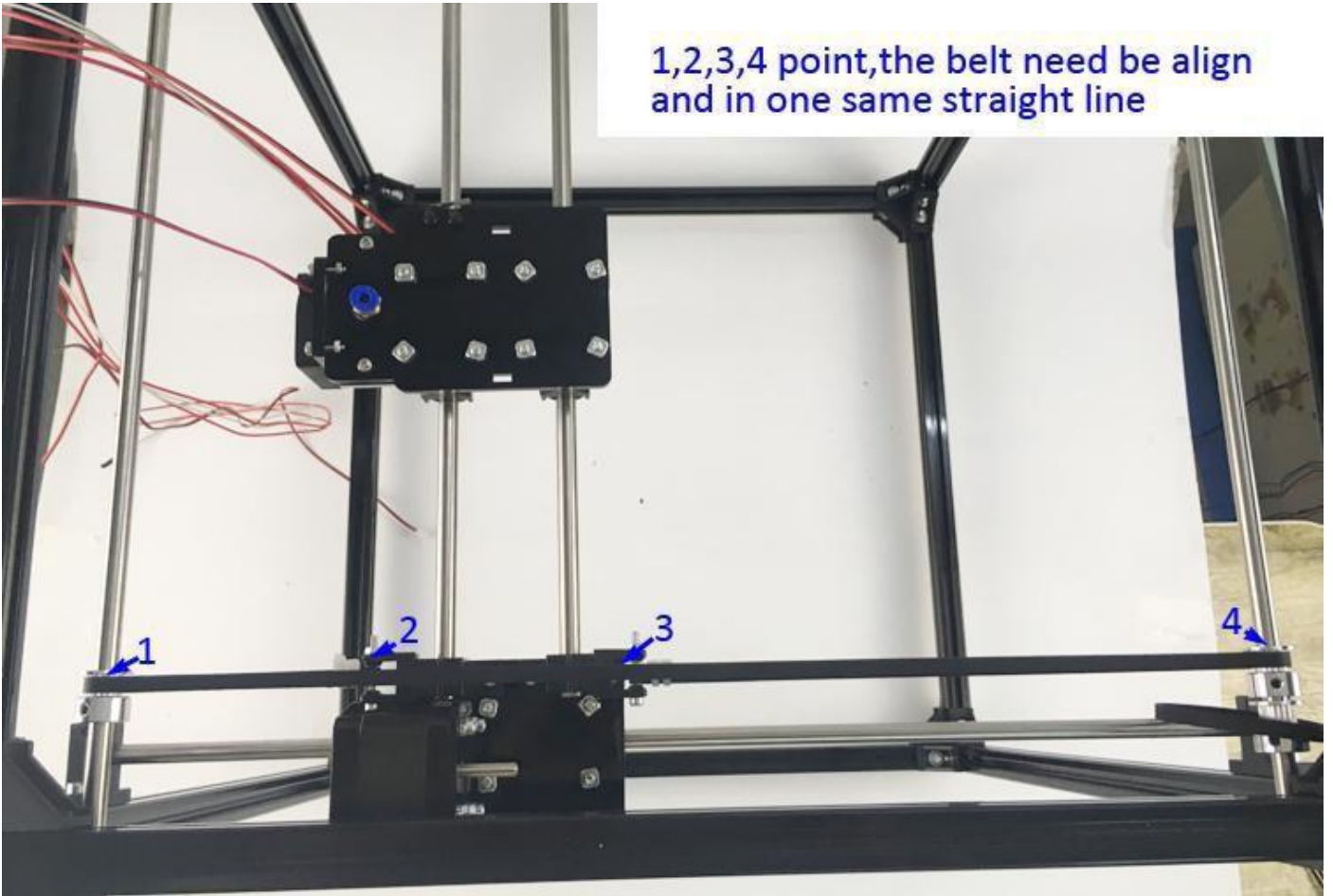

firmly fixed

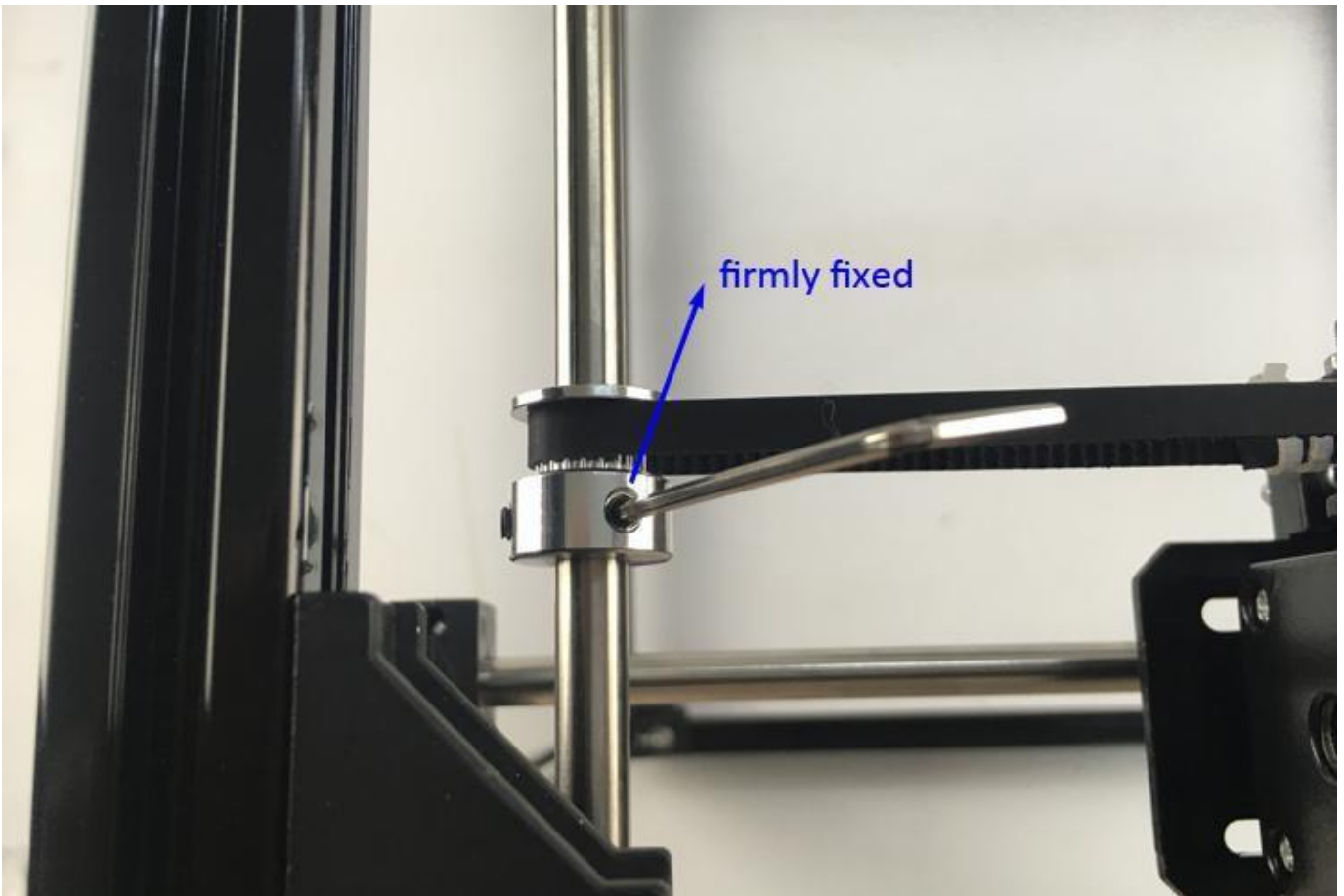

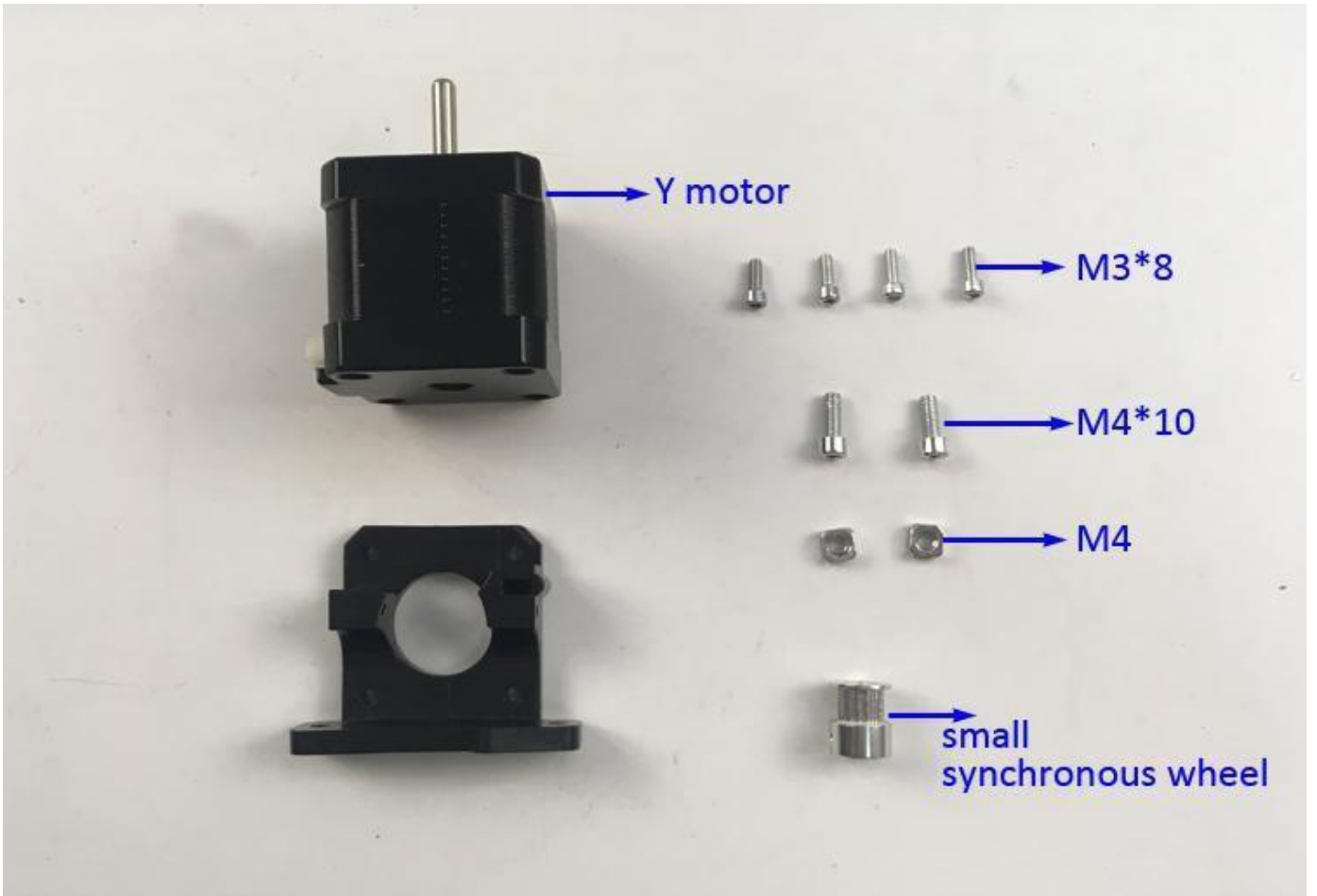
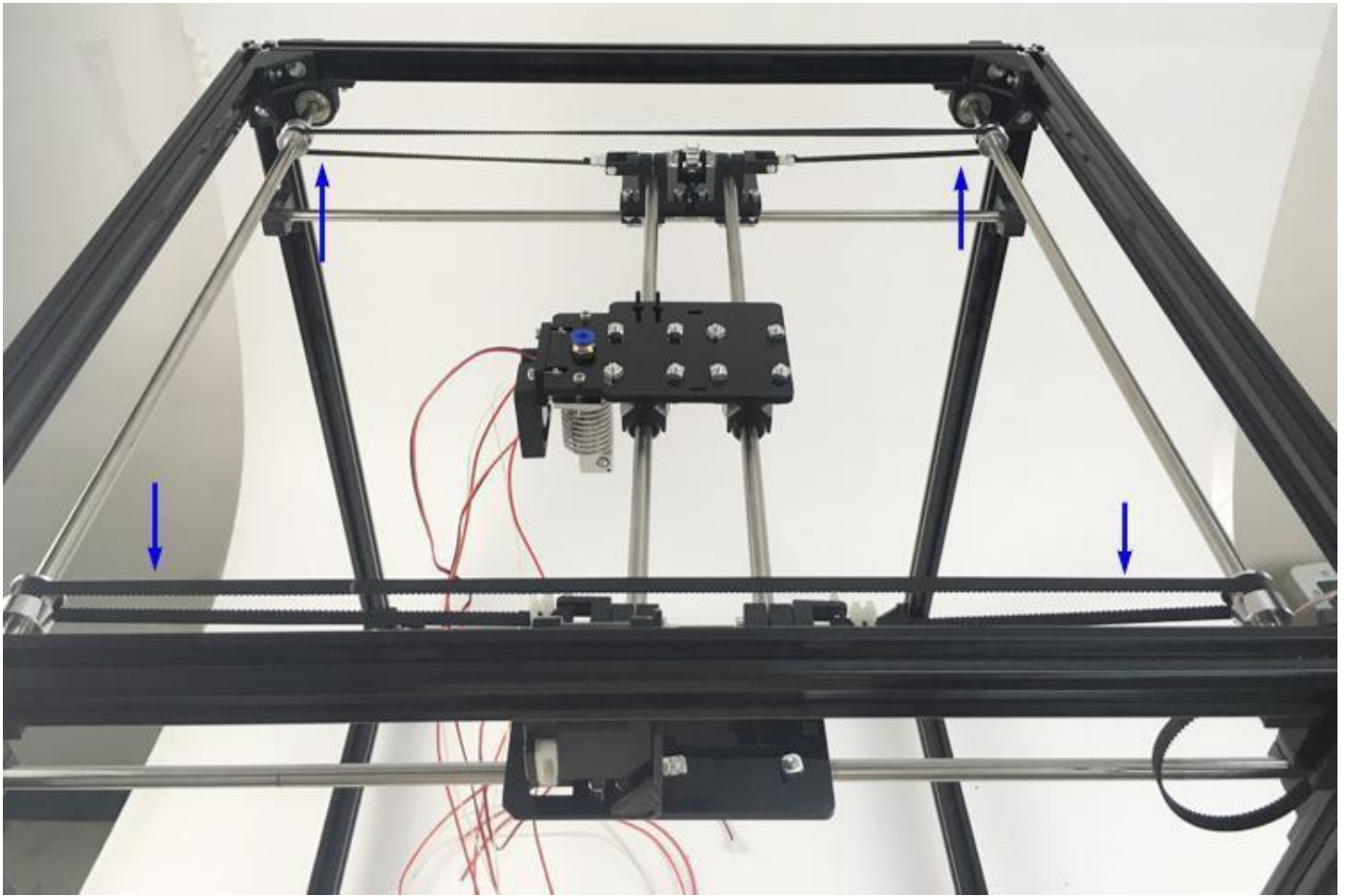

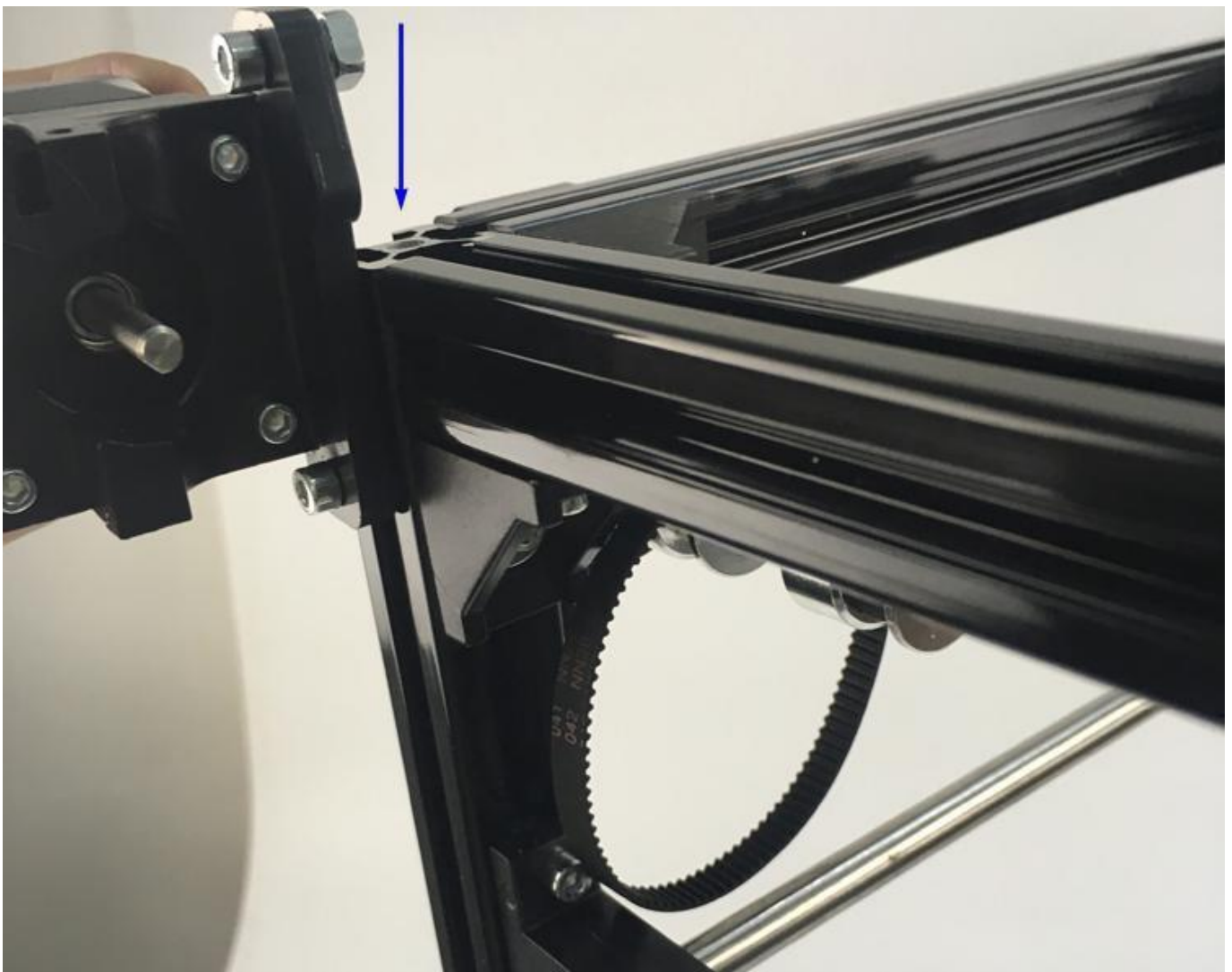
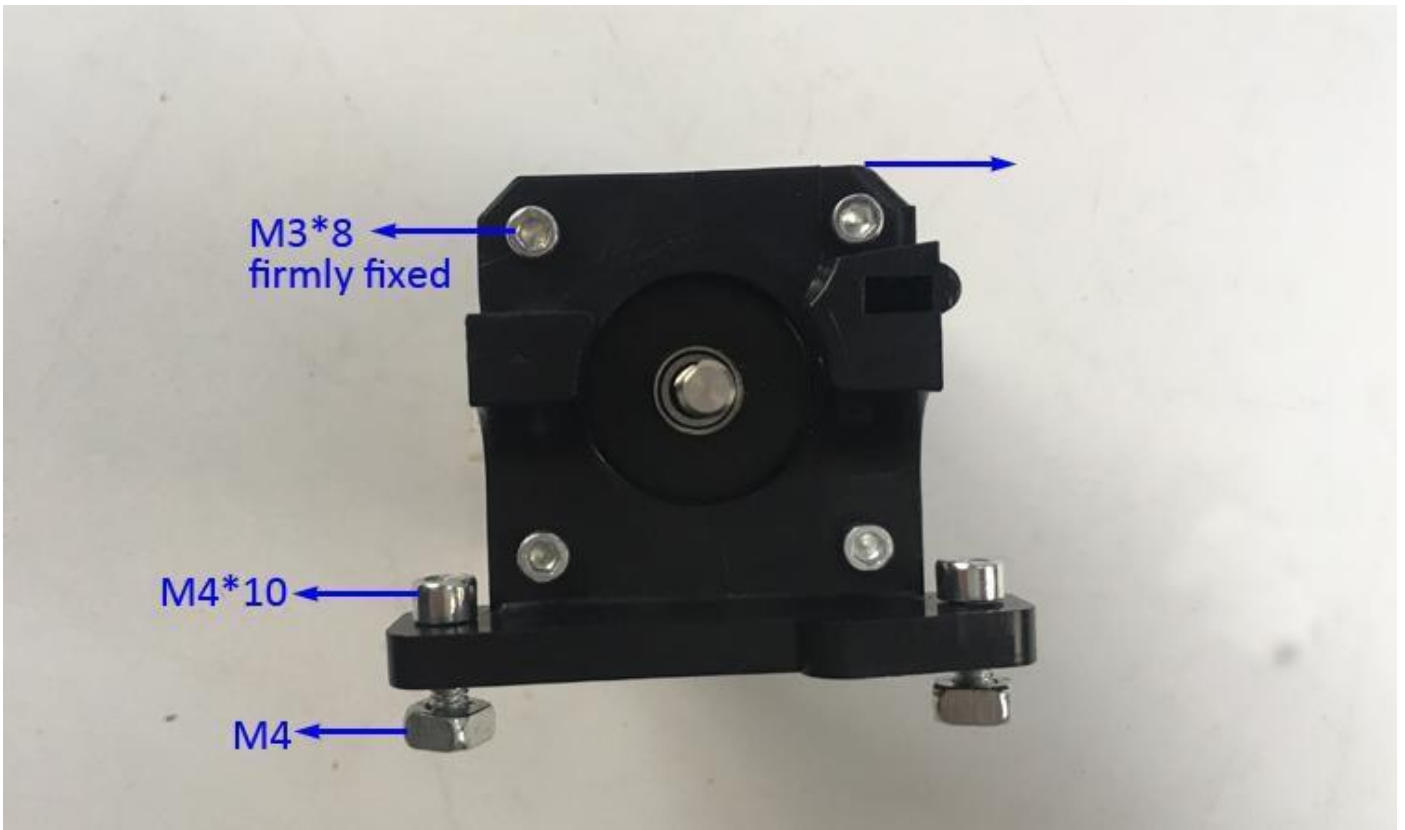

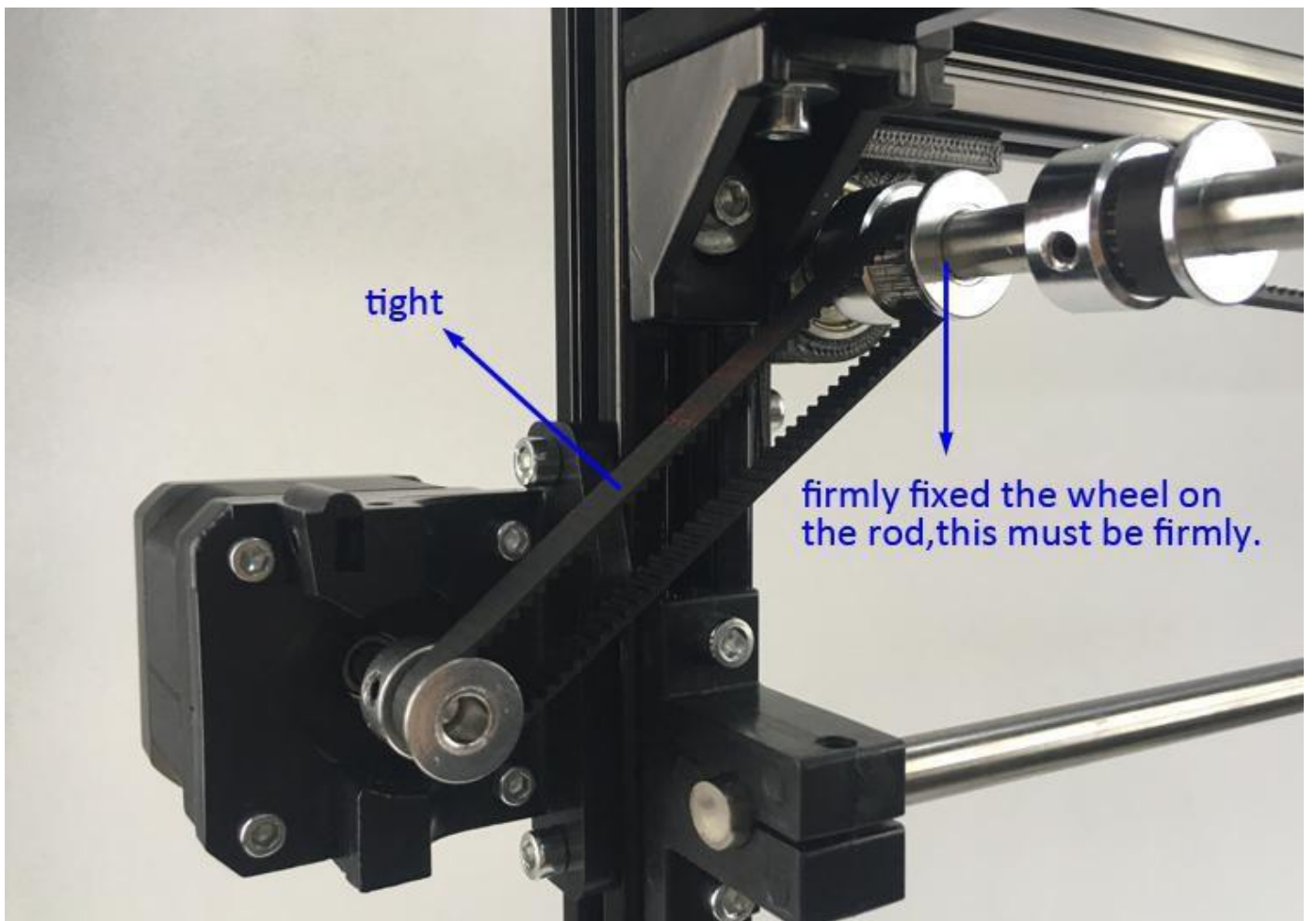
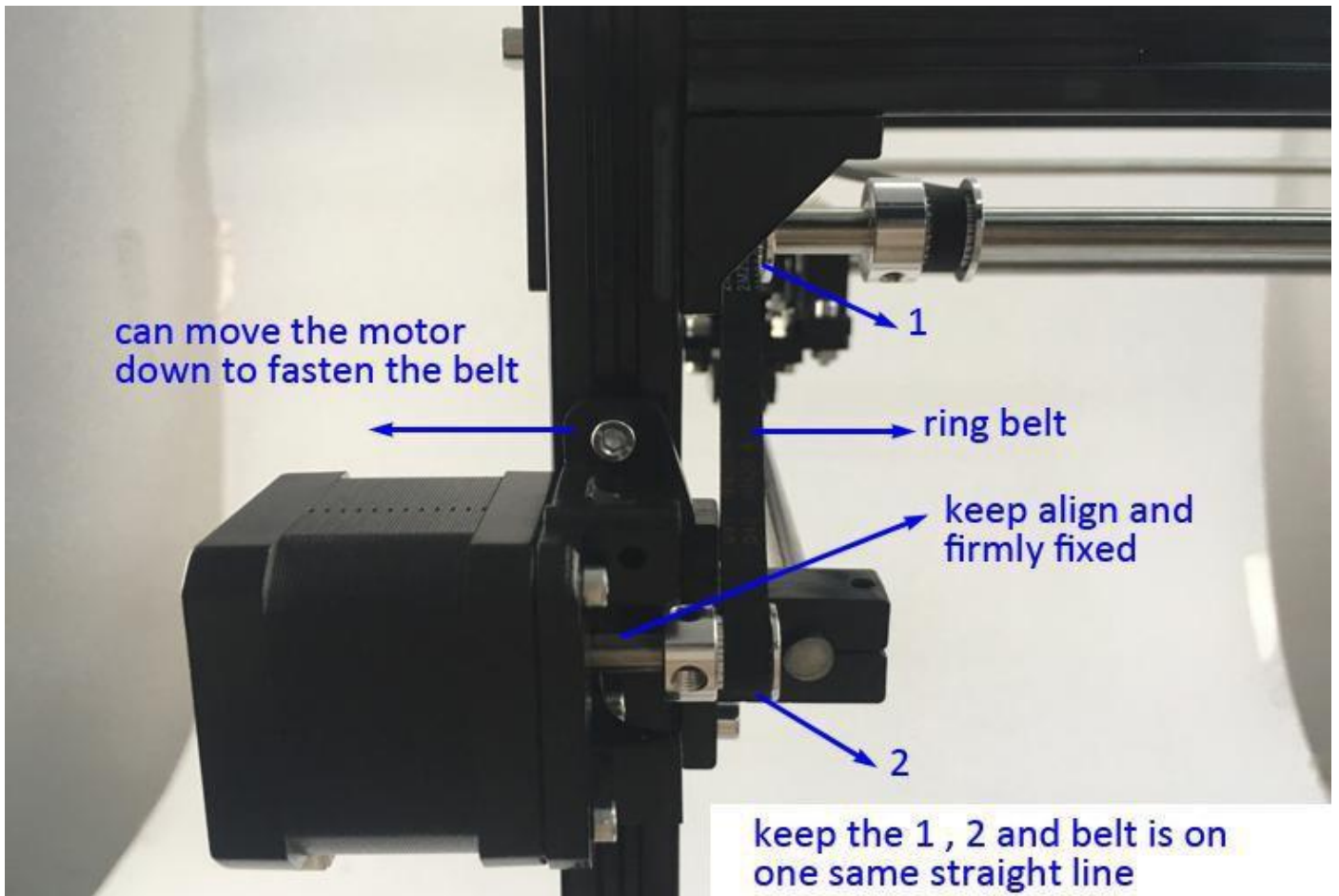

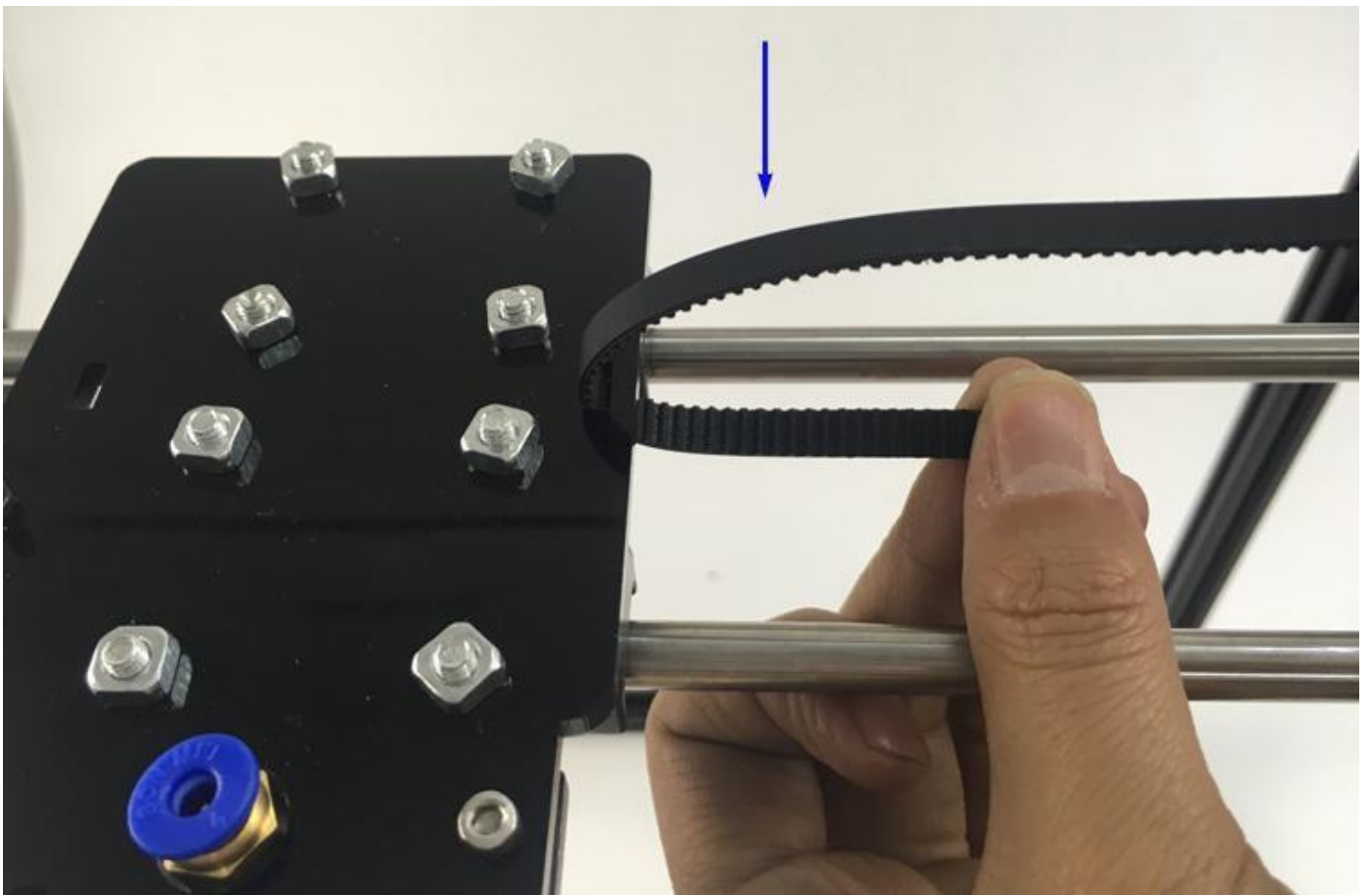
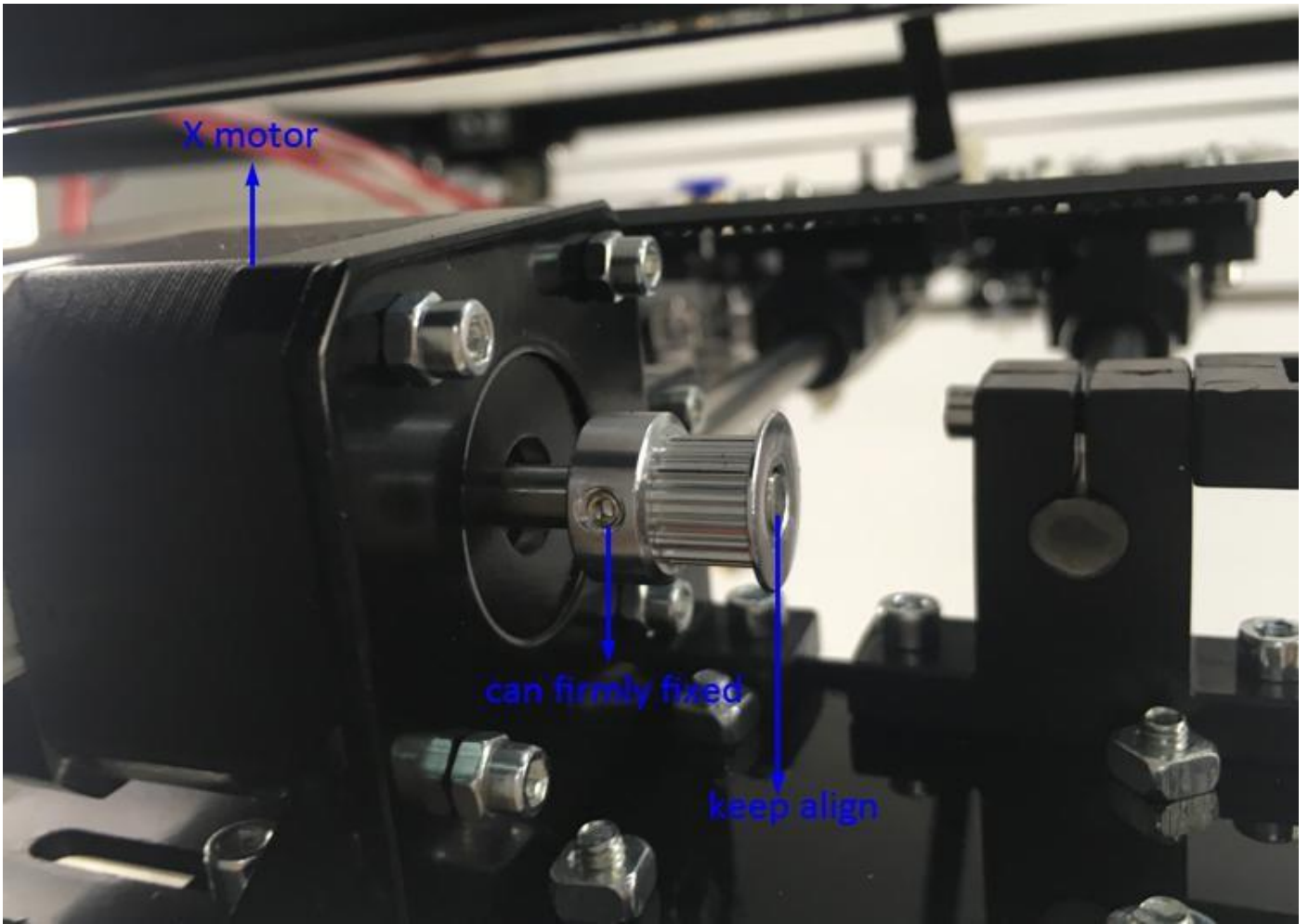



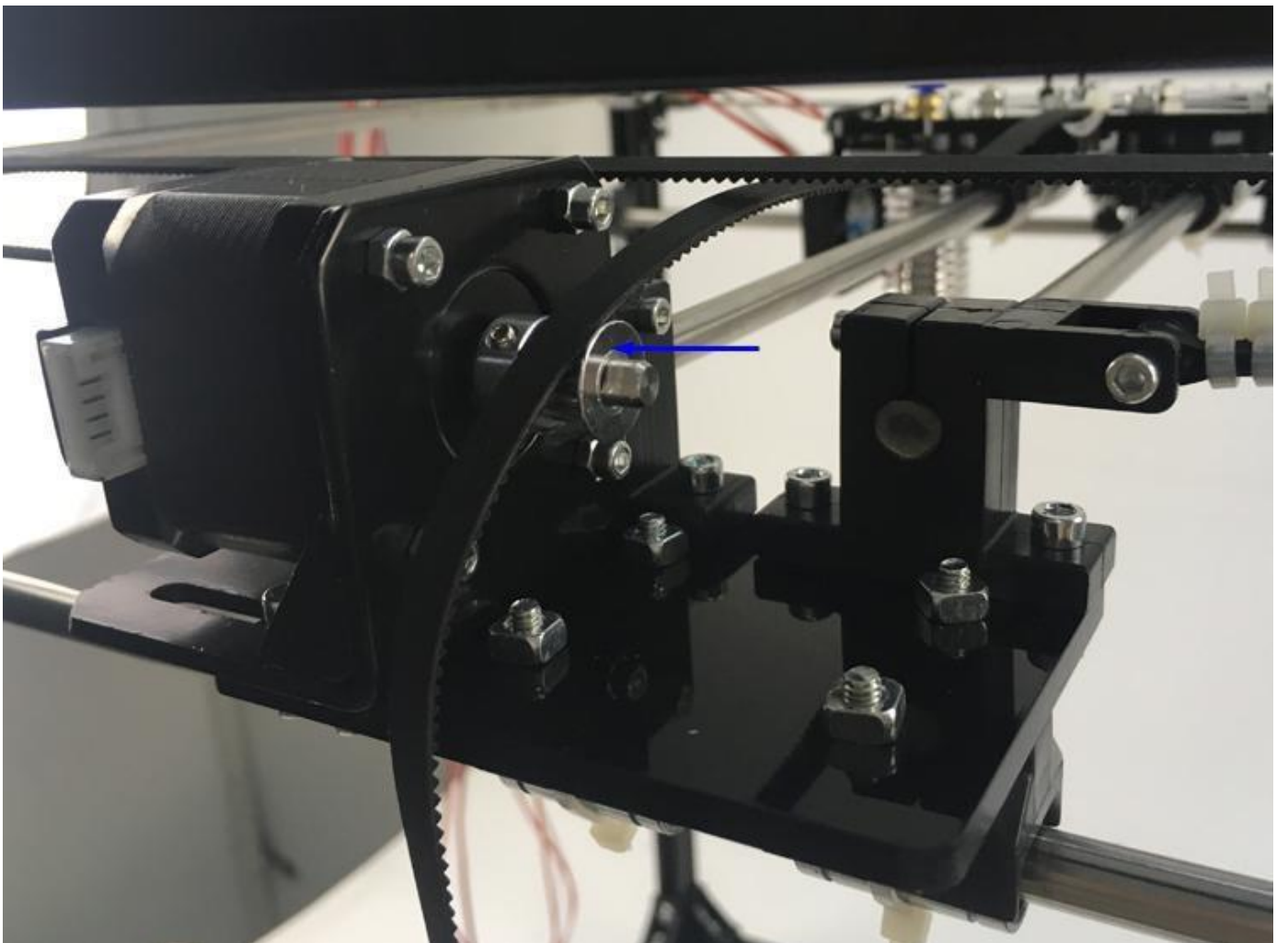
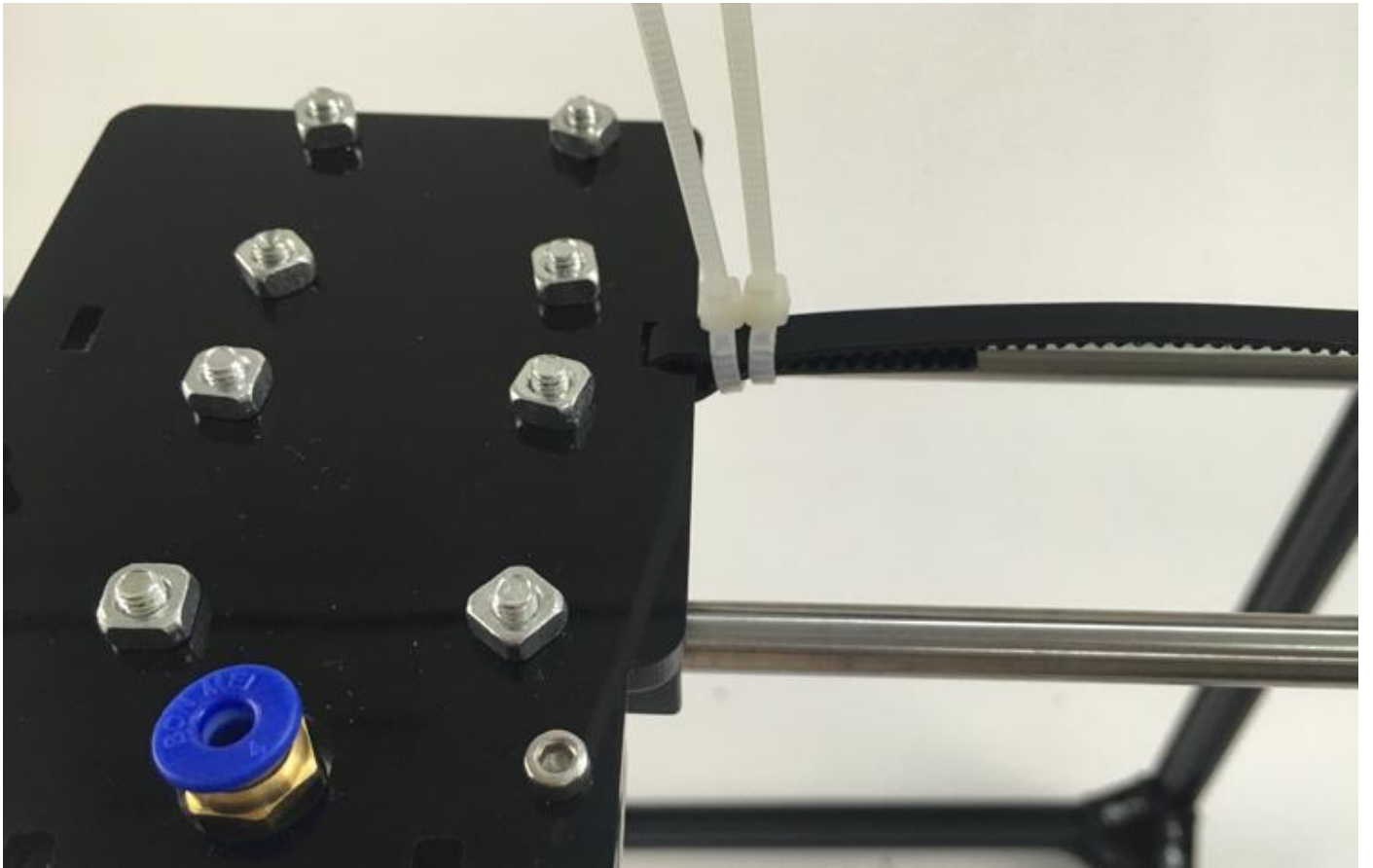

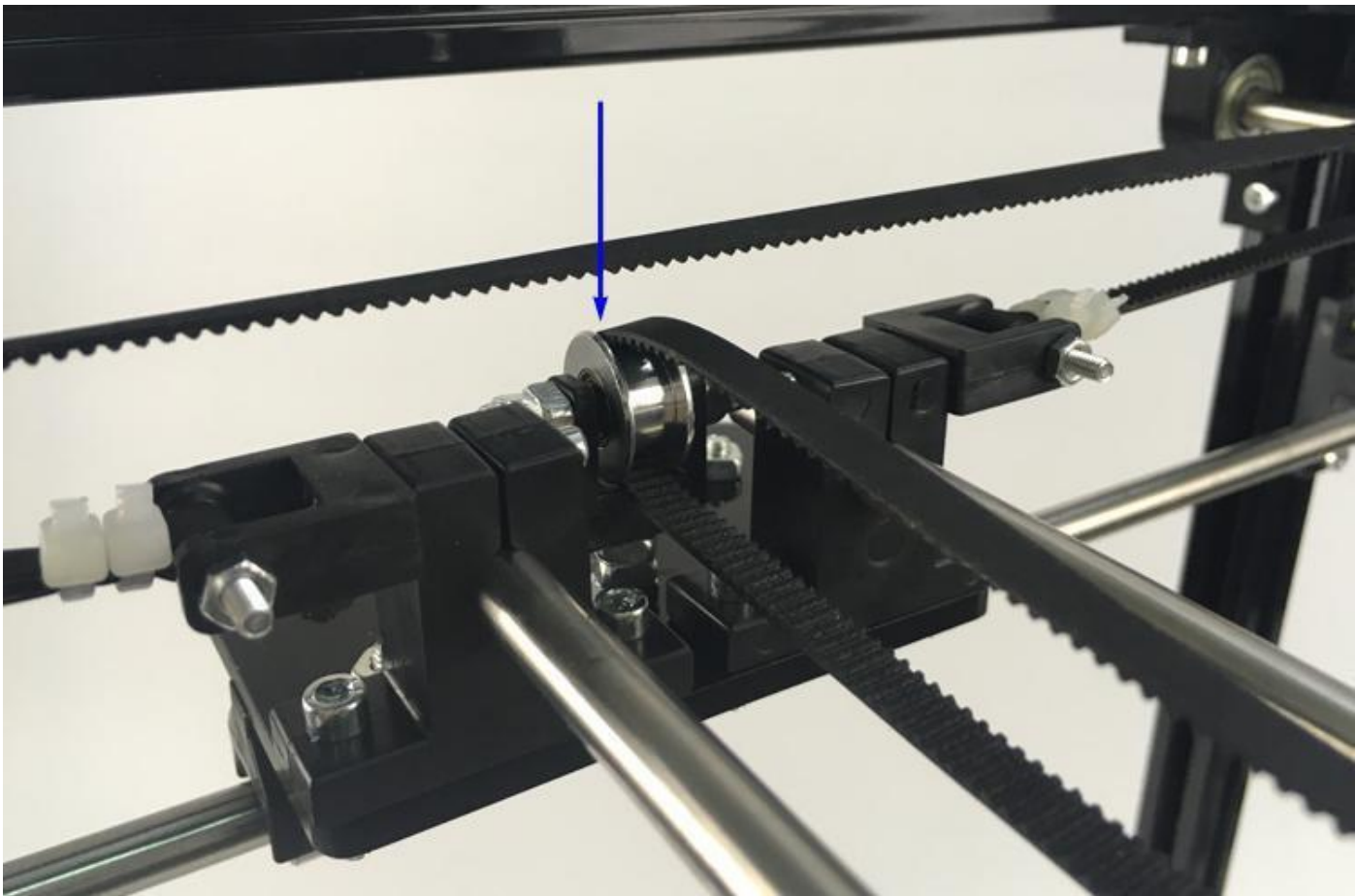

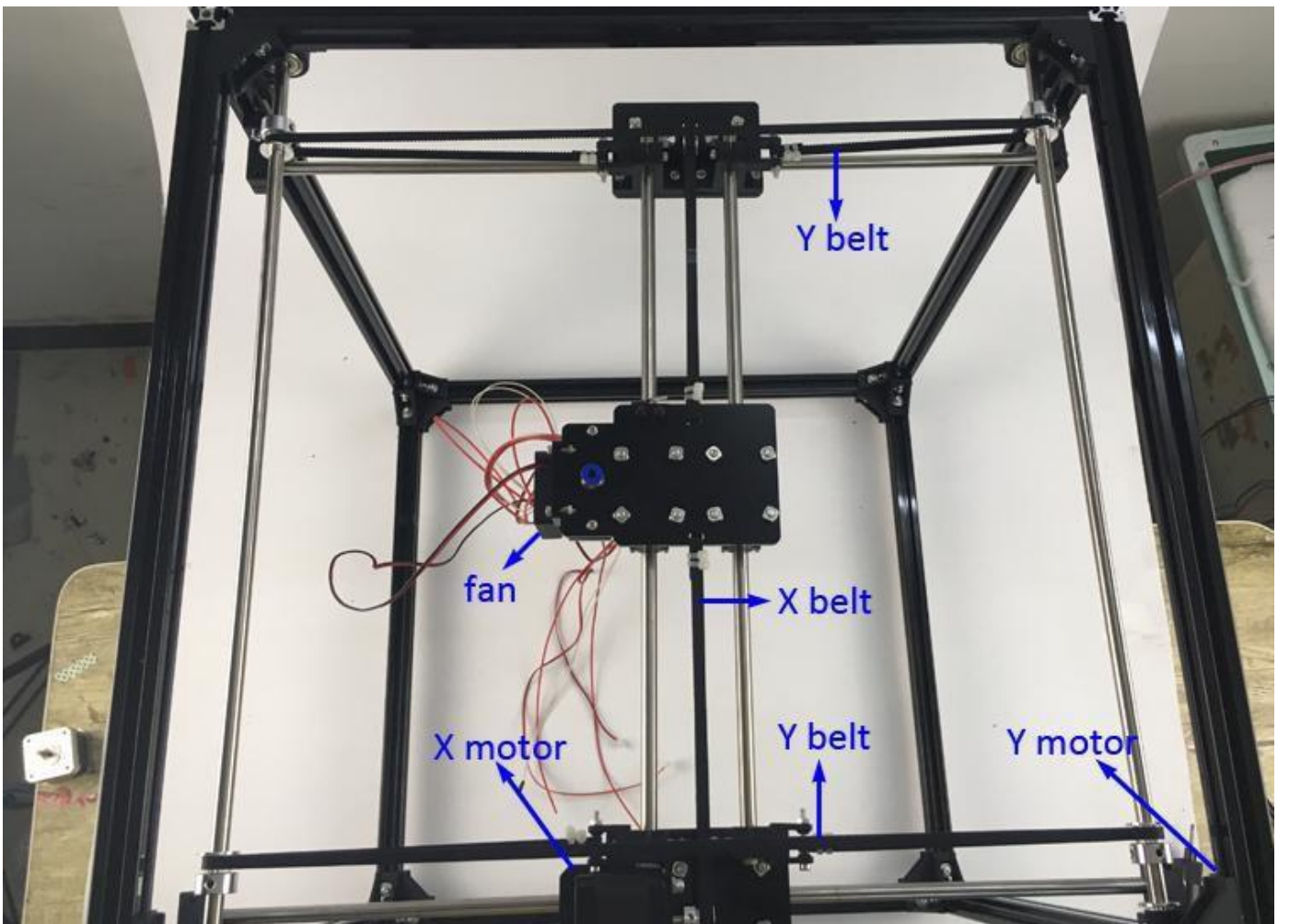
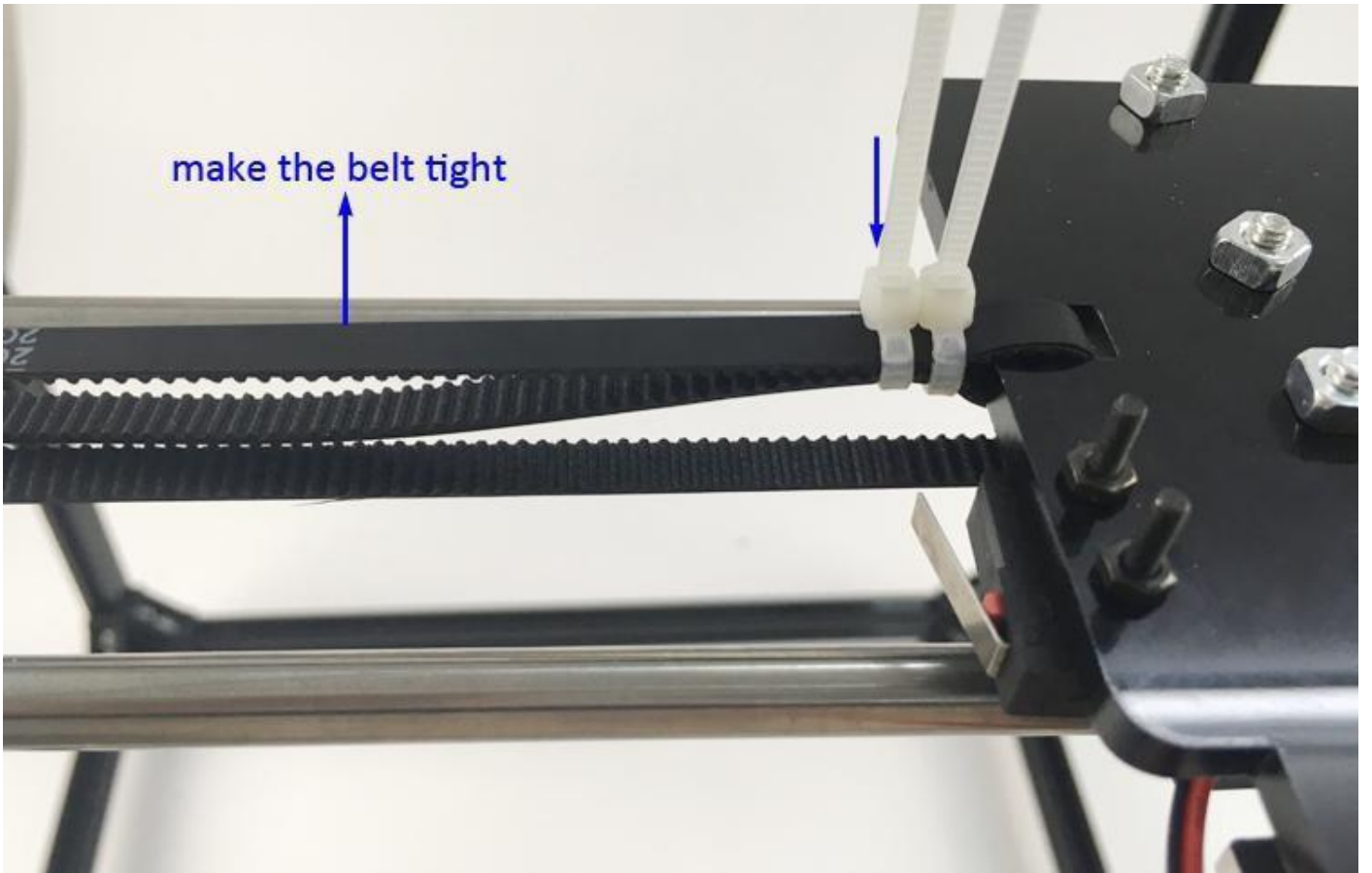

### 3 Assembly Z axis

in order to make it convenient and clearly to assembly Z and plate. we define the front and back,now,this angle is front,it's important. from front angle,can see the fan and X motor directly.

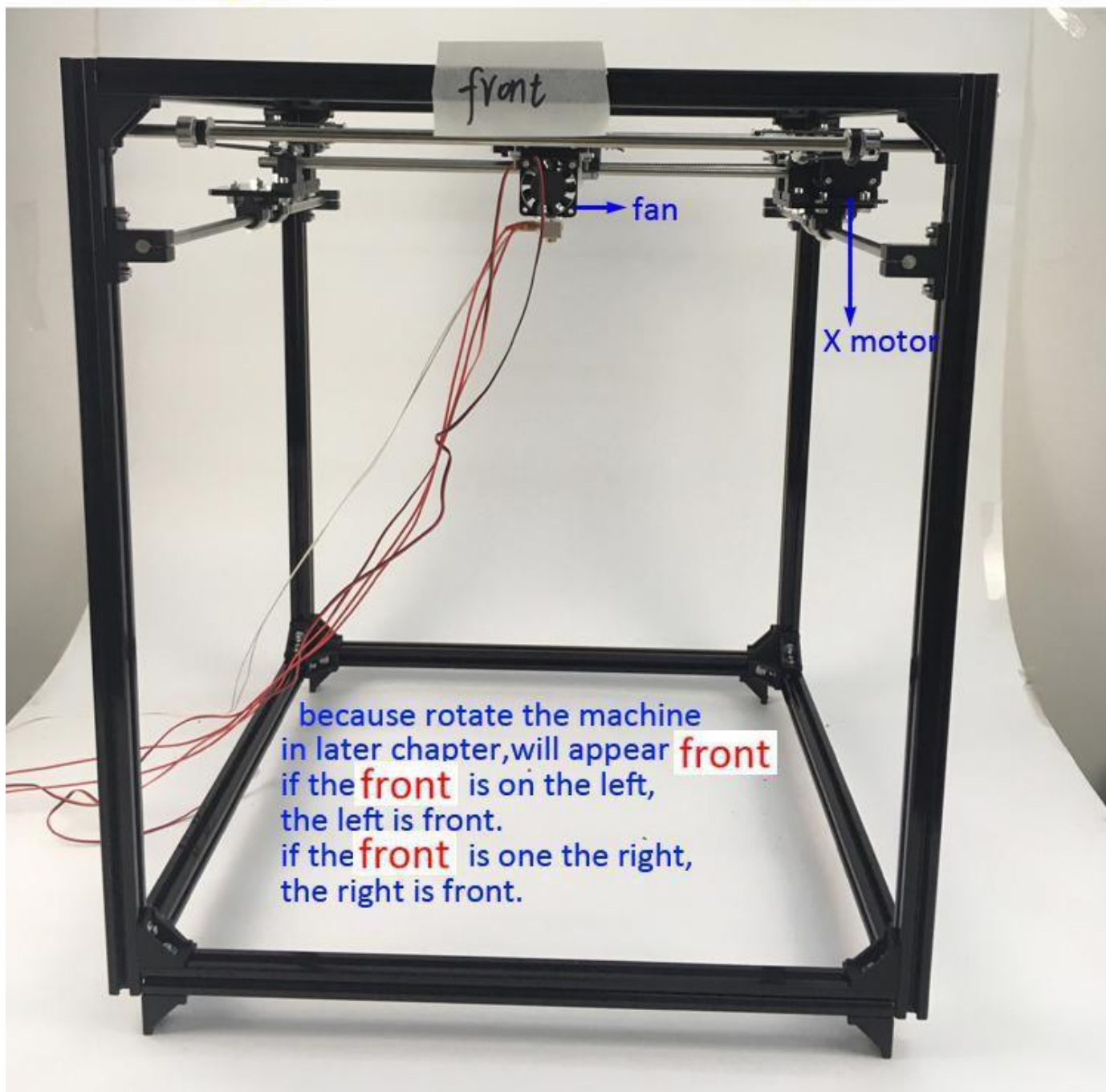

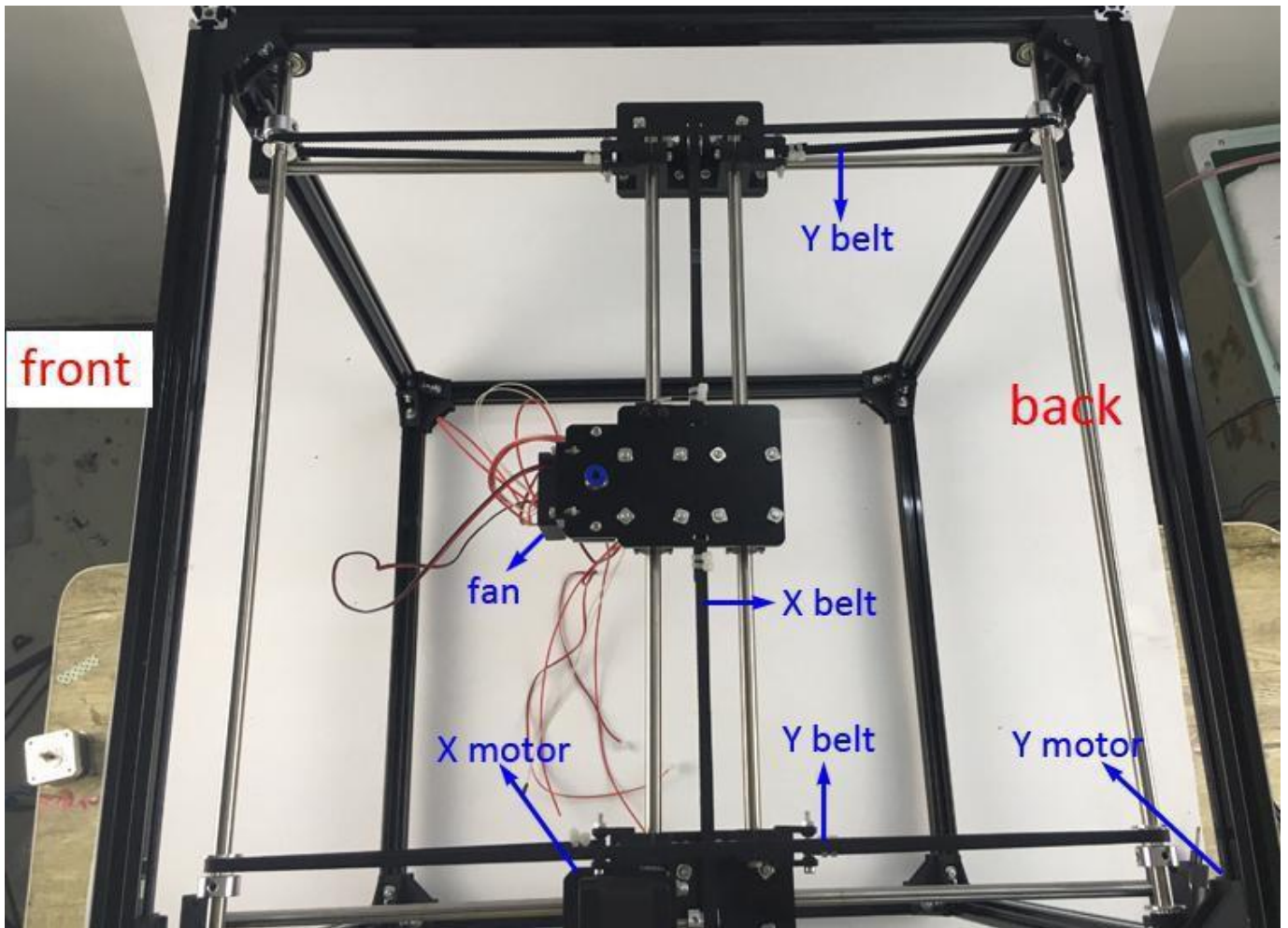

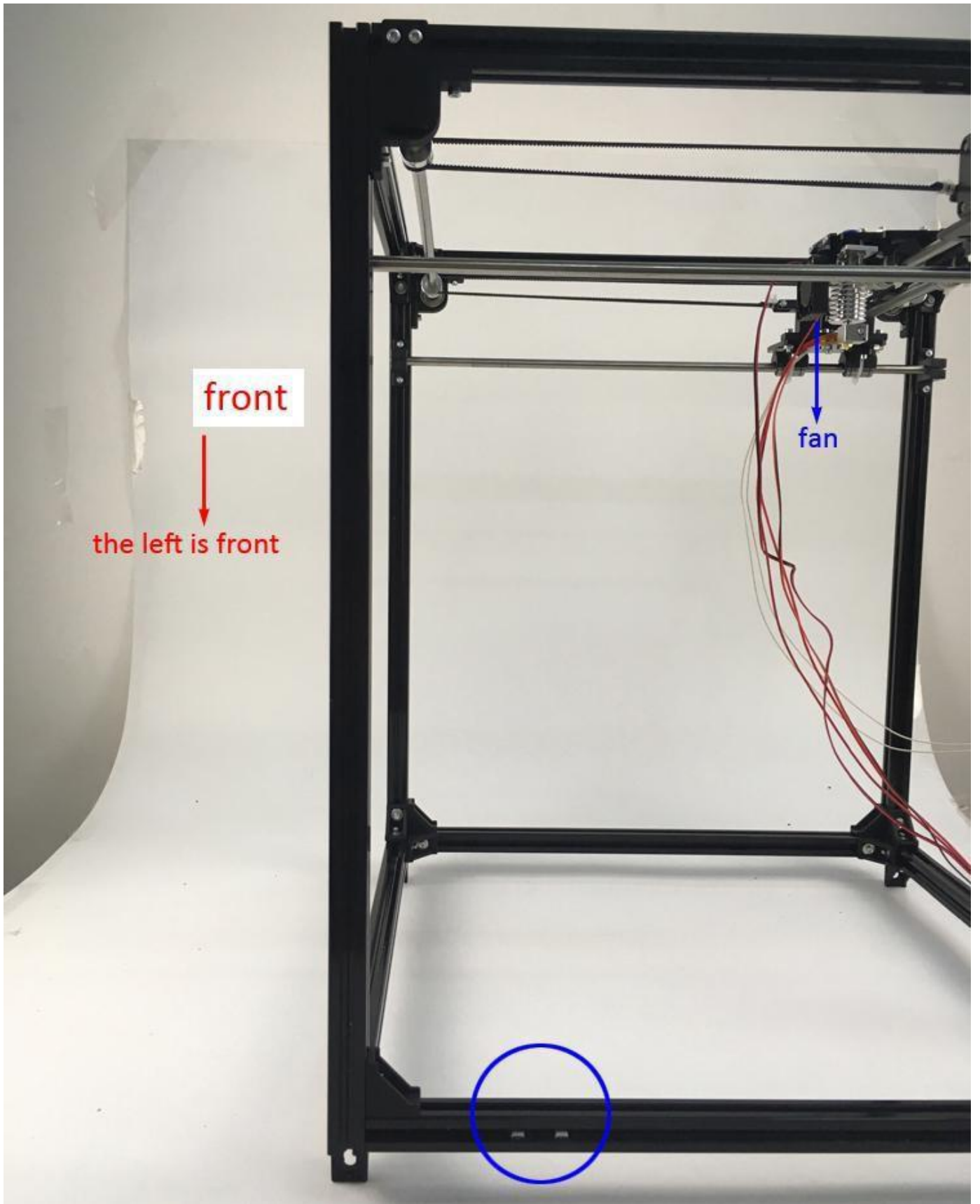

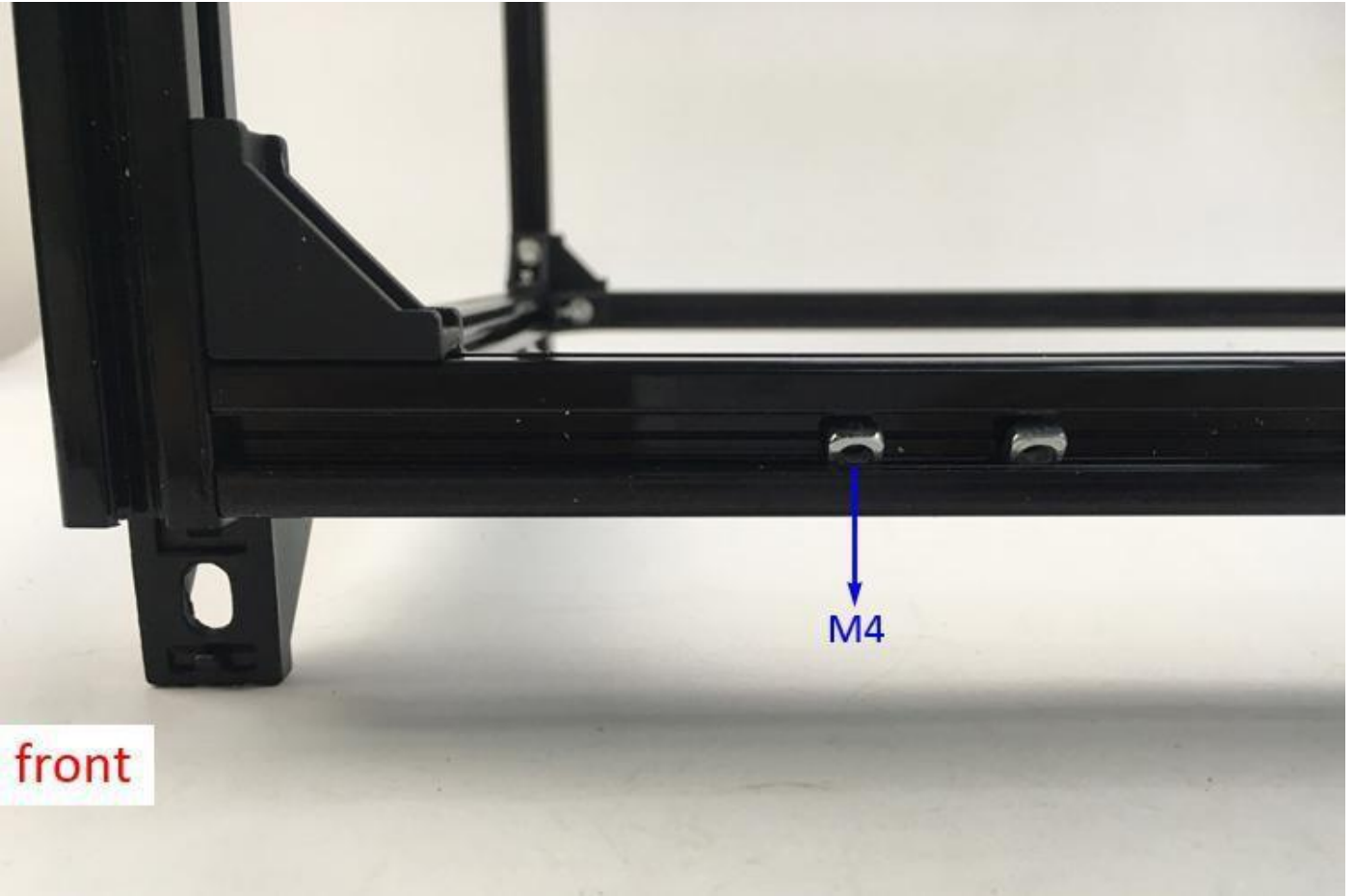

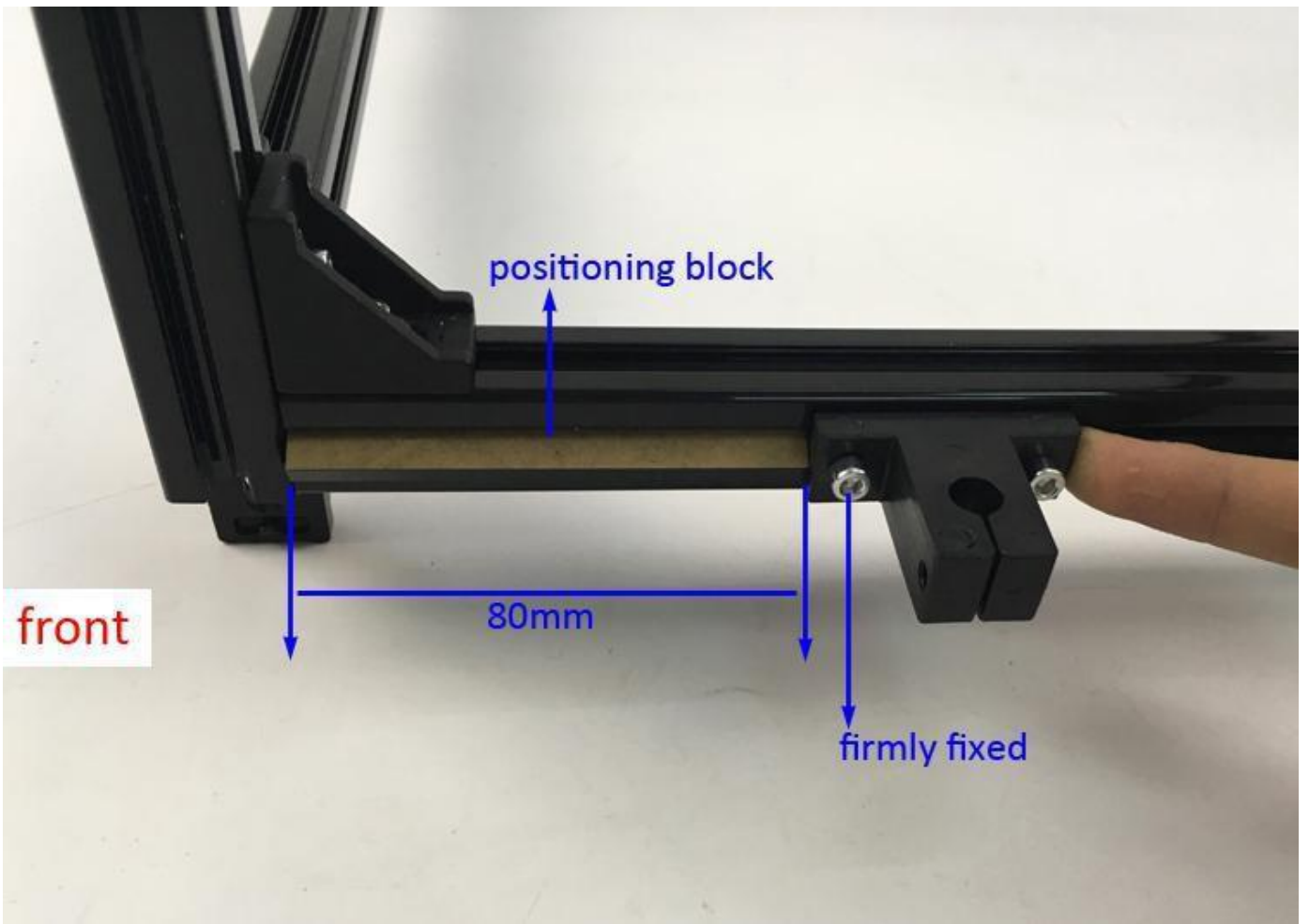



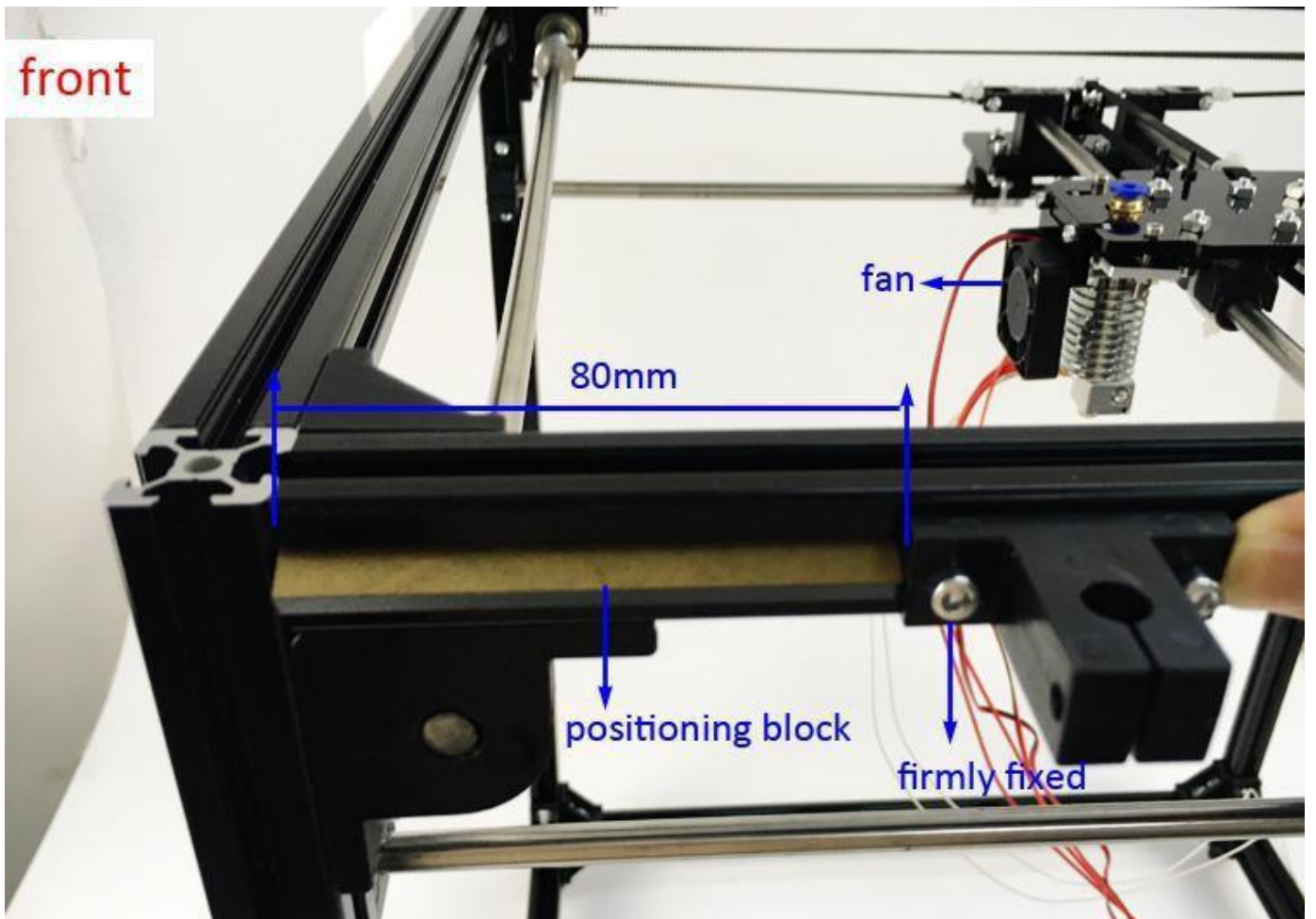
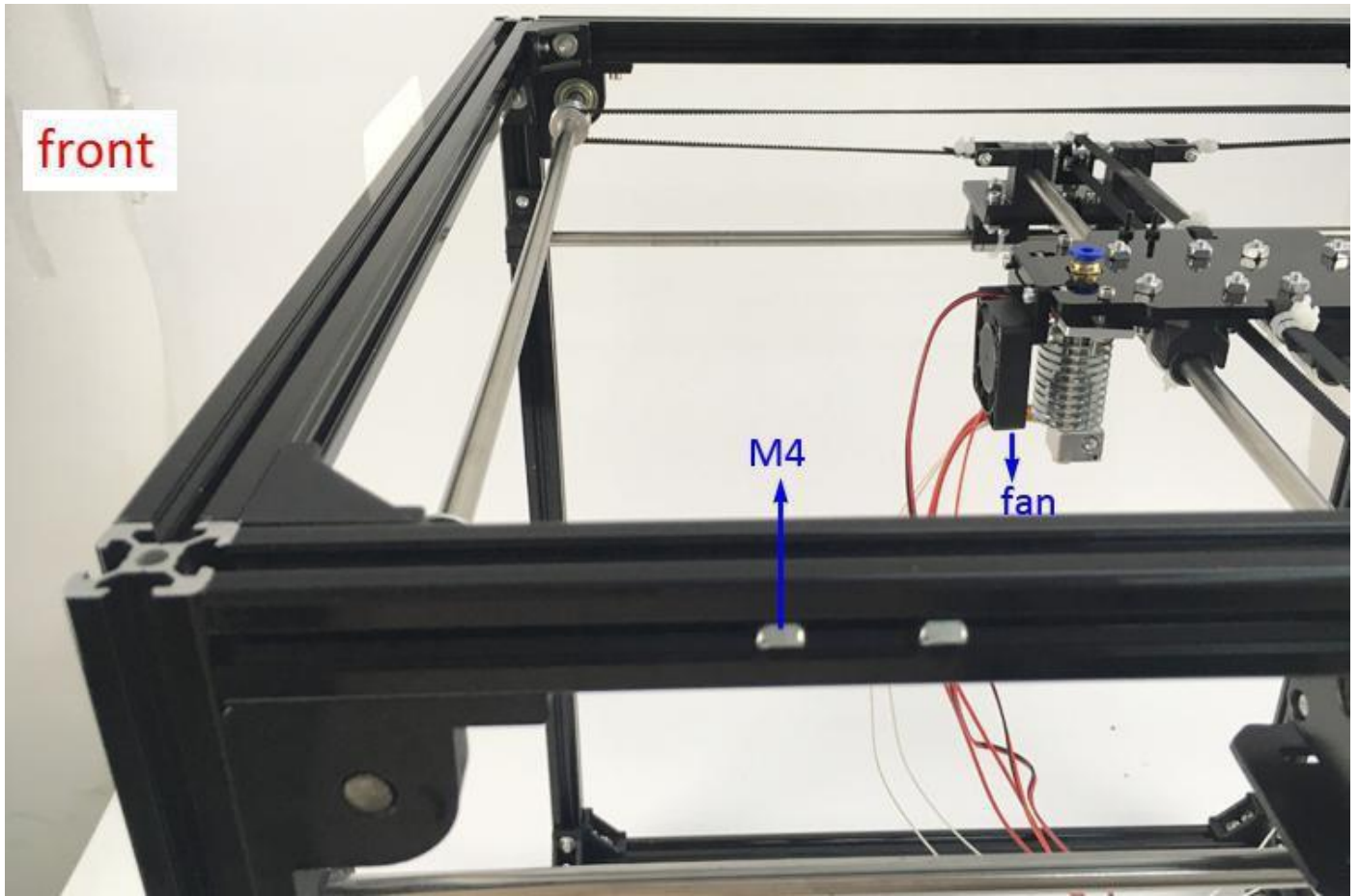

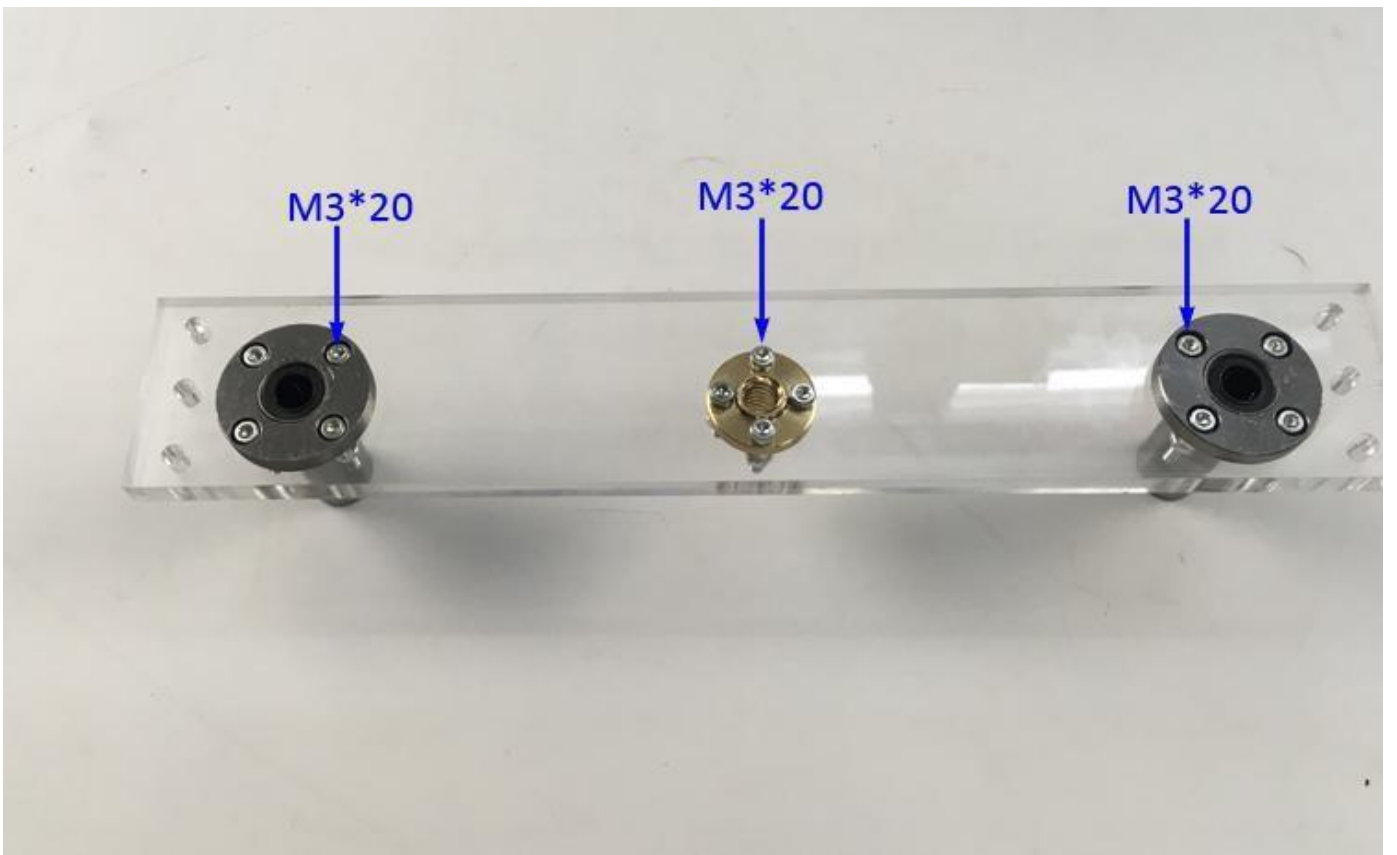

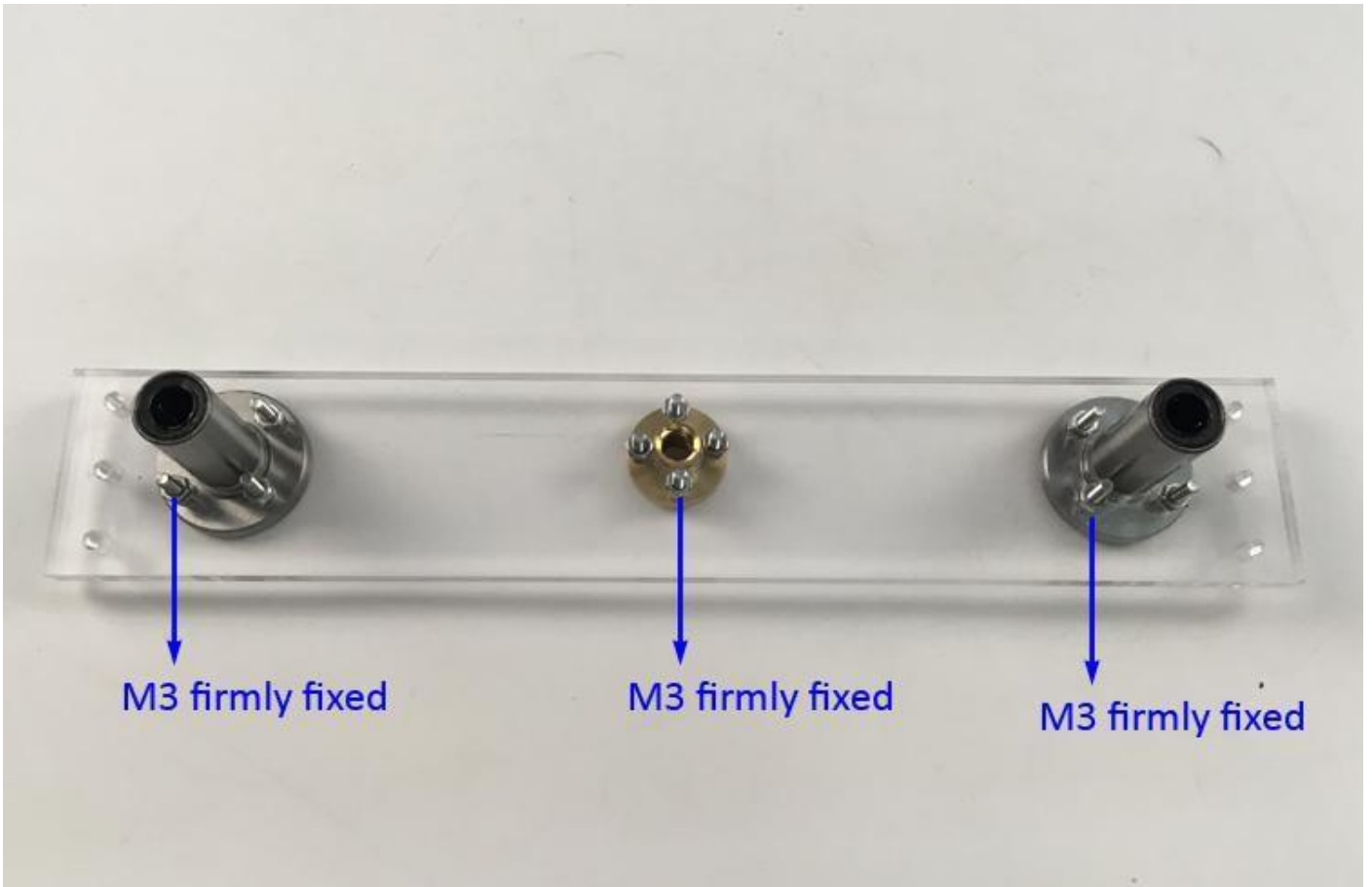

the yellow round center to the edge, one is long, another is short.  
when the rod go through the bearing, the long must be put inside  
and the short must be put outside.

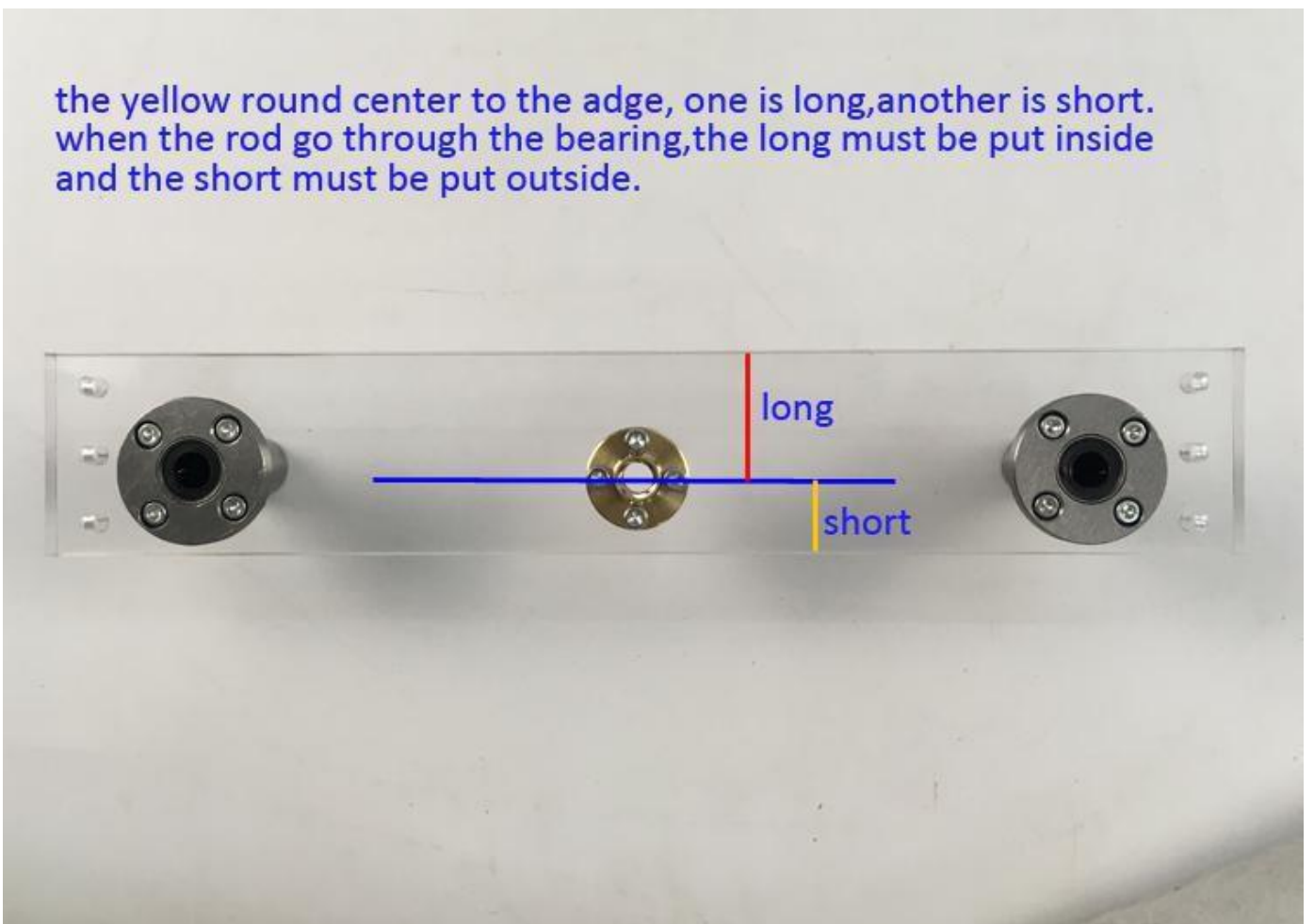

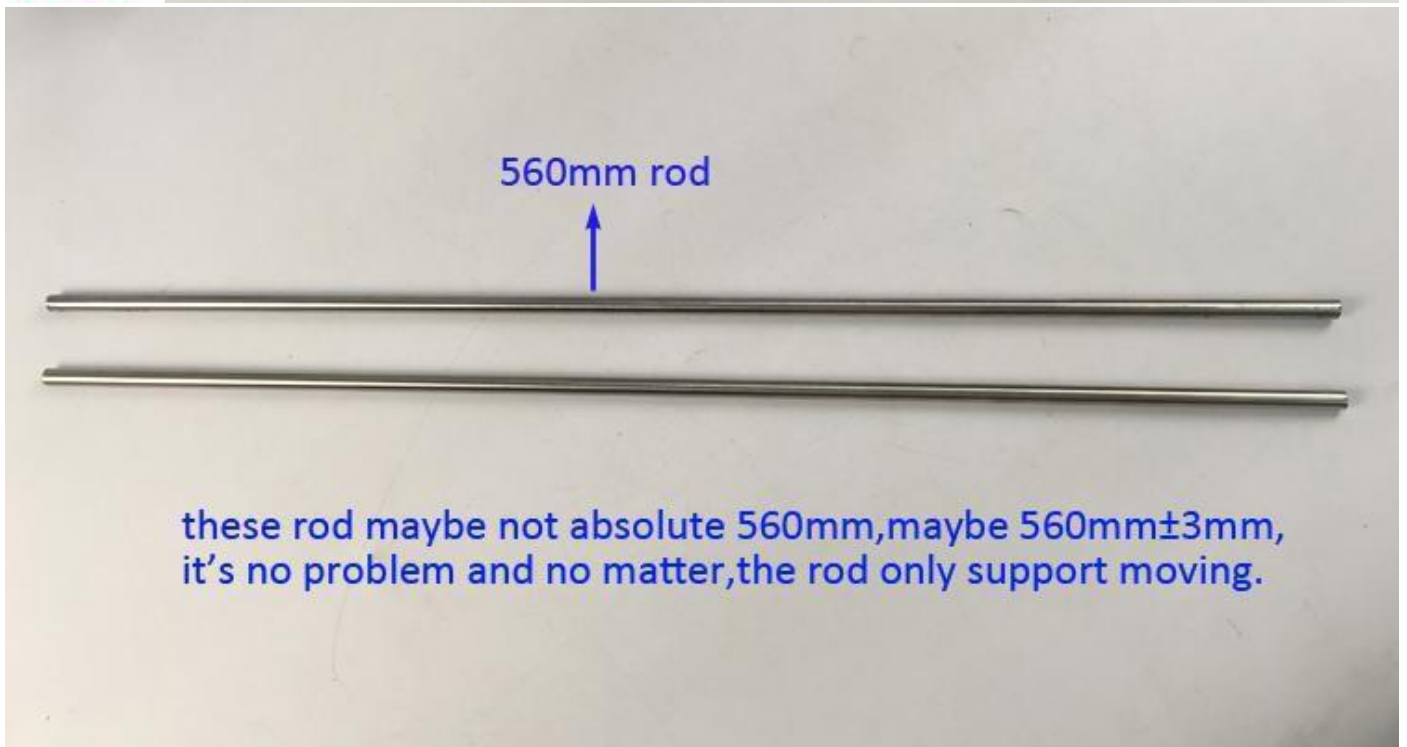
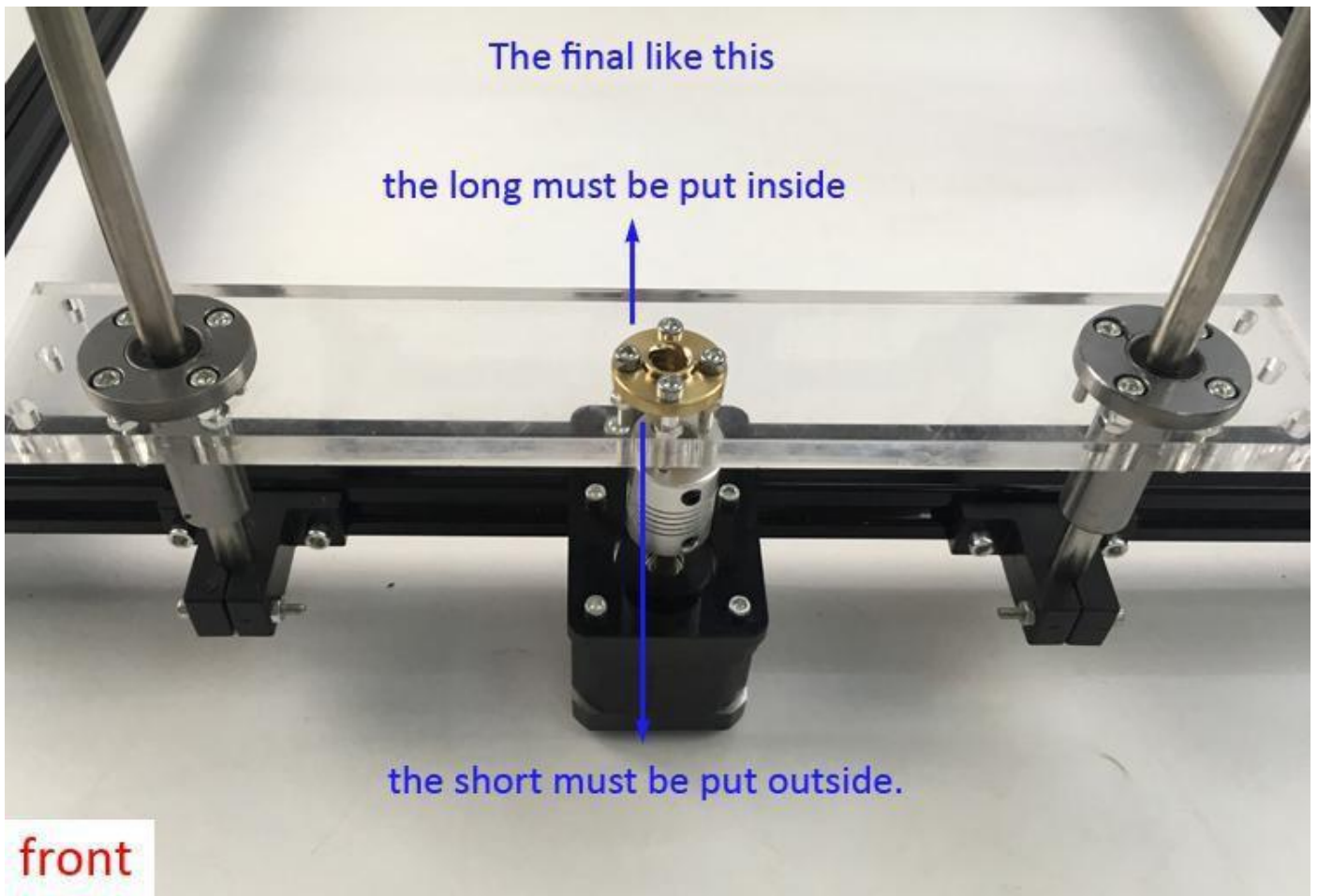

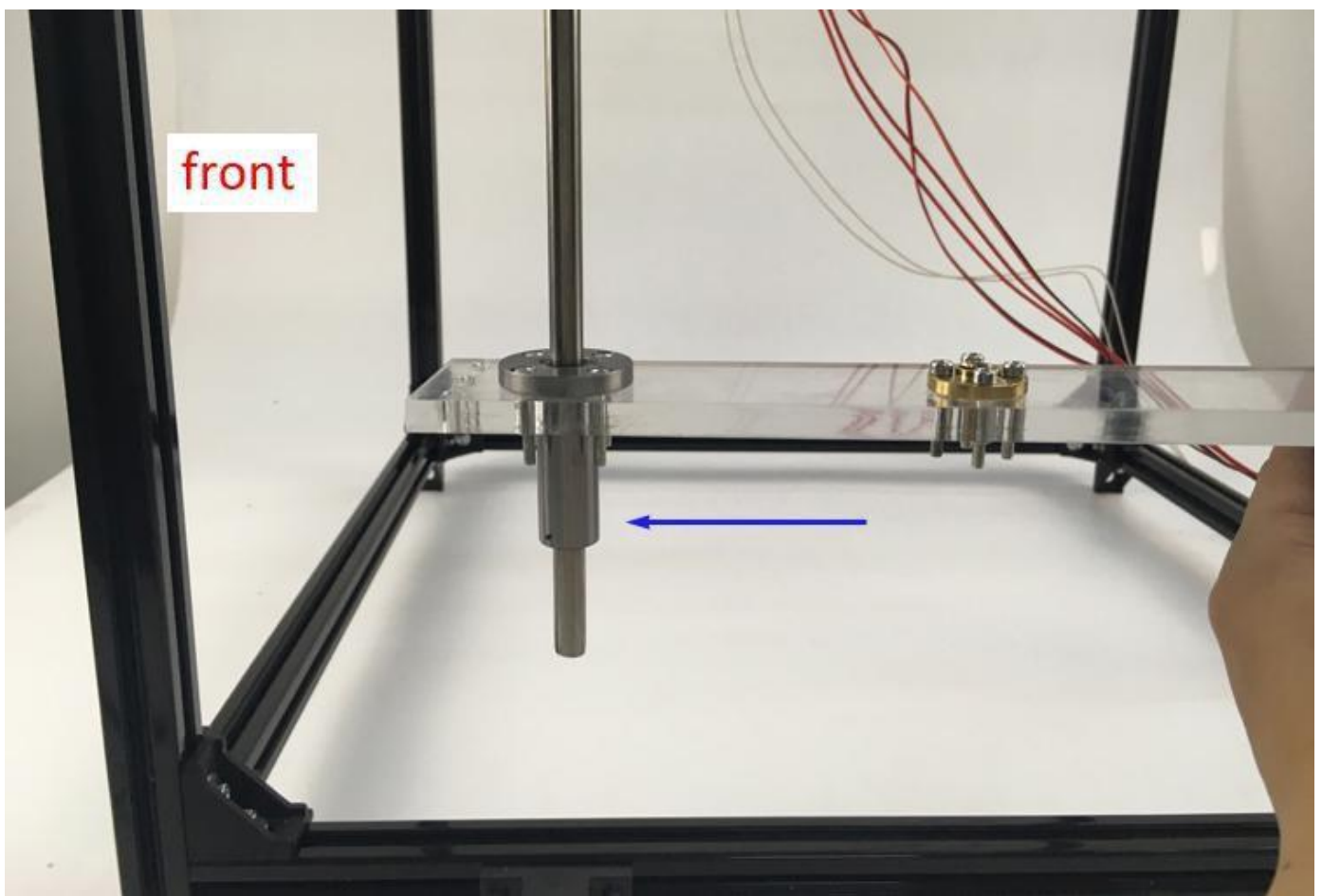
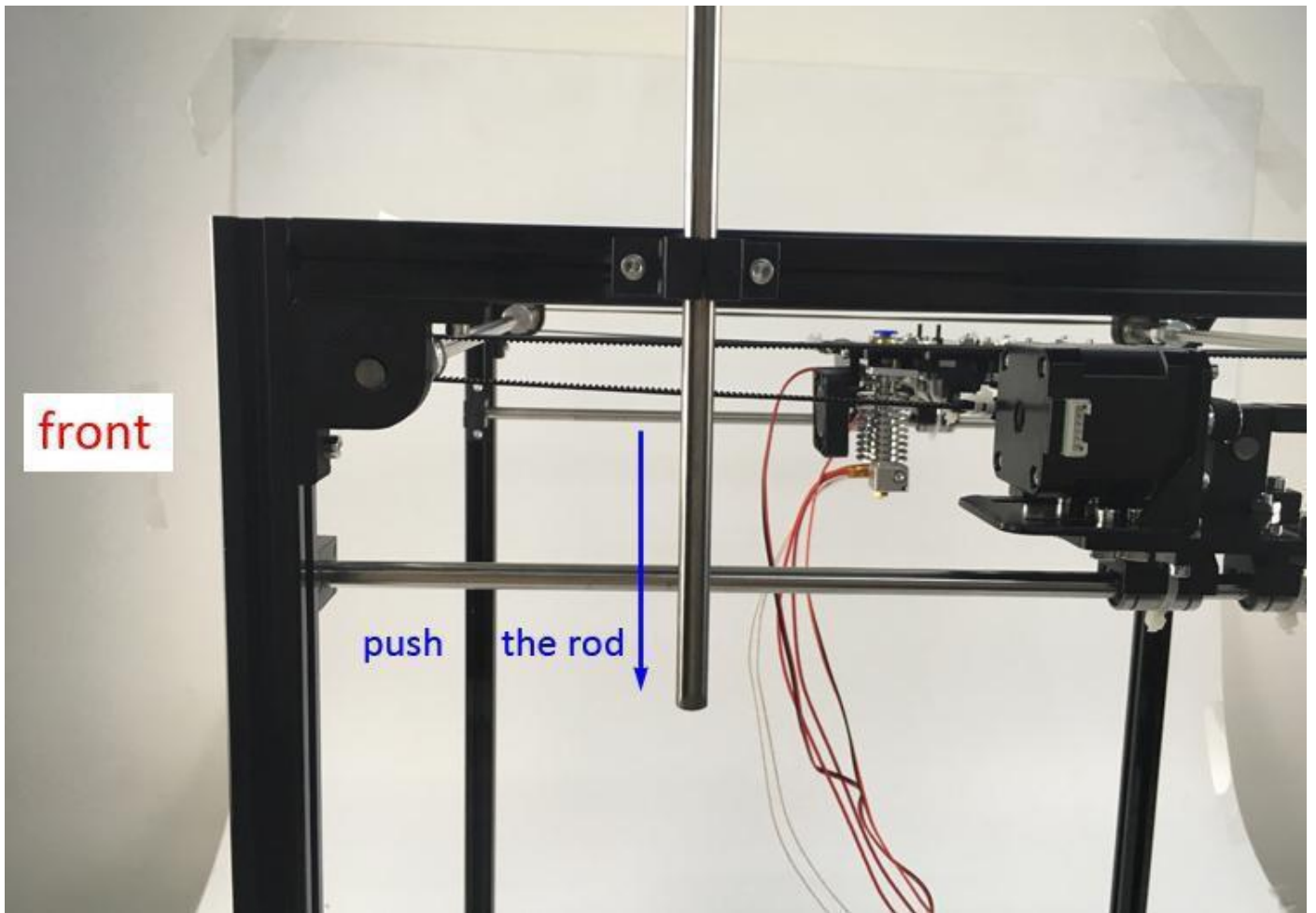

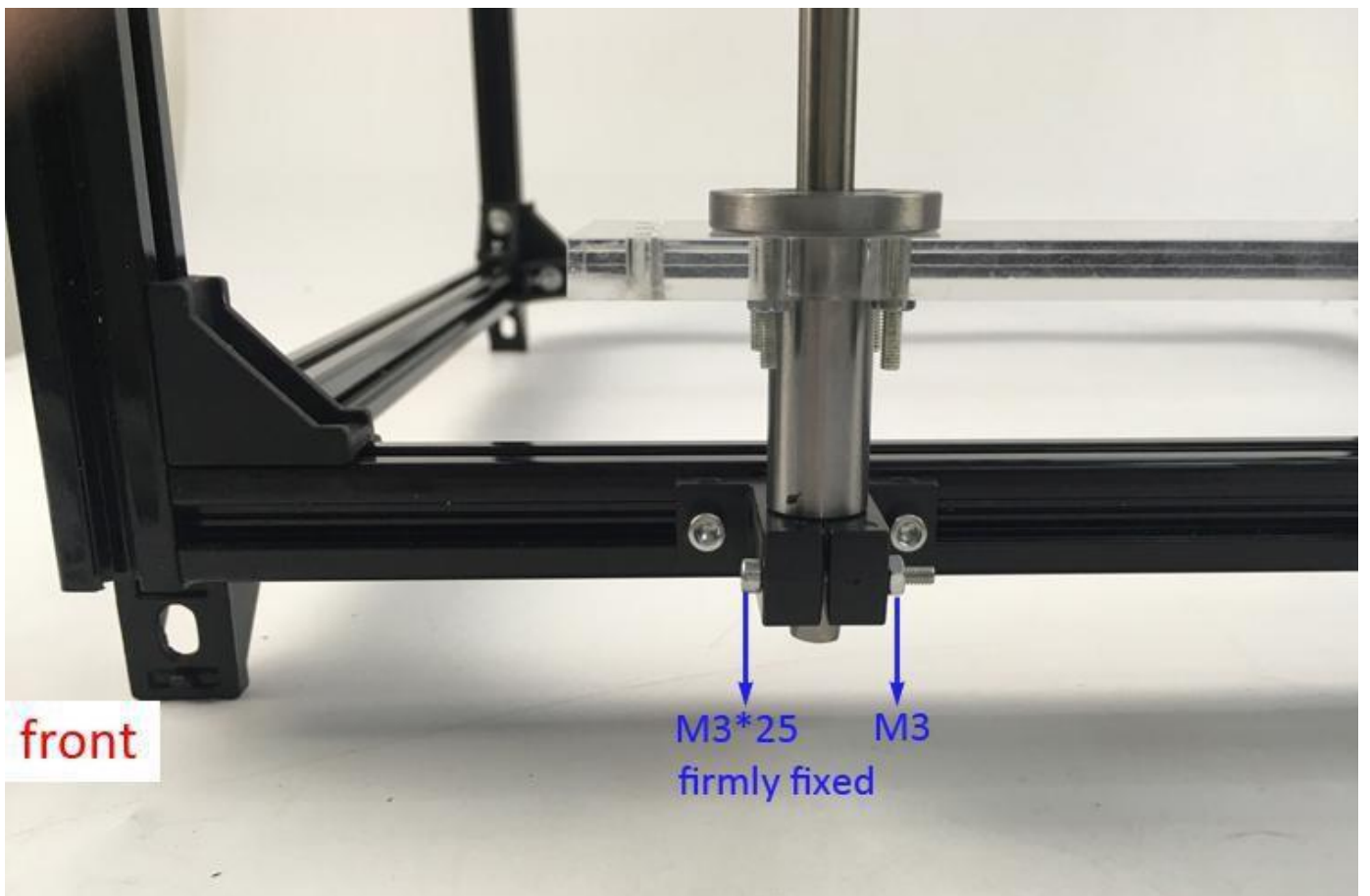
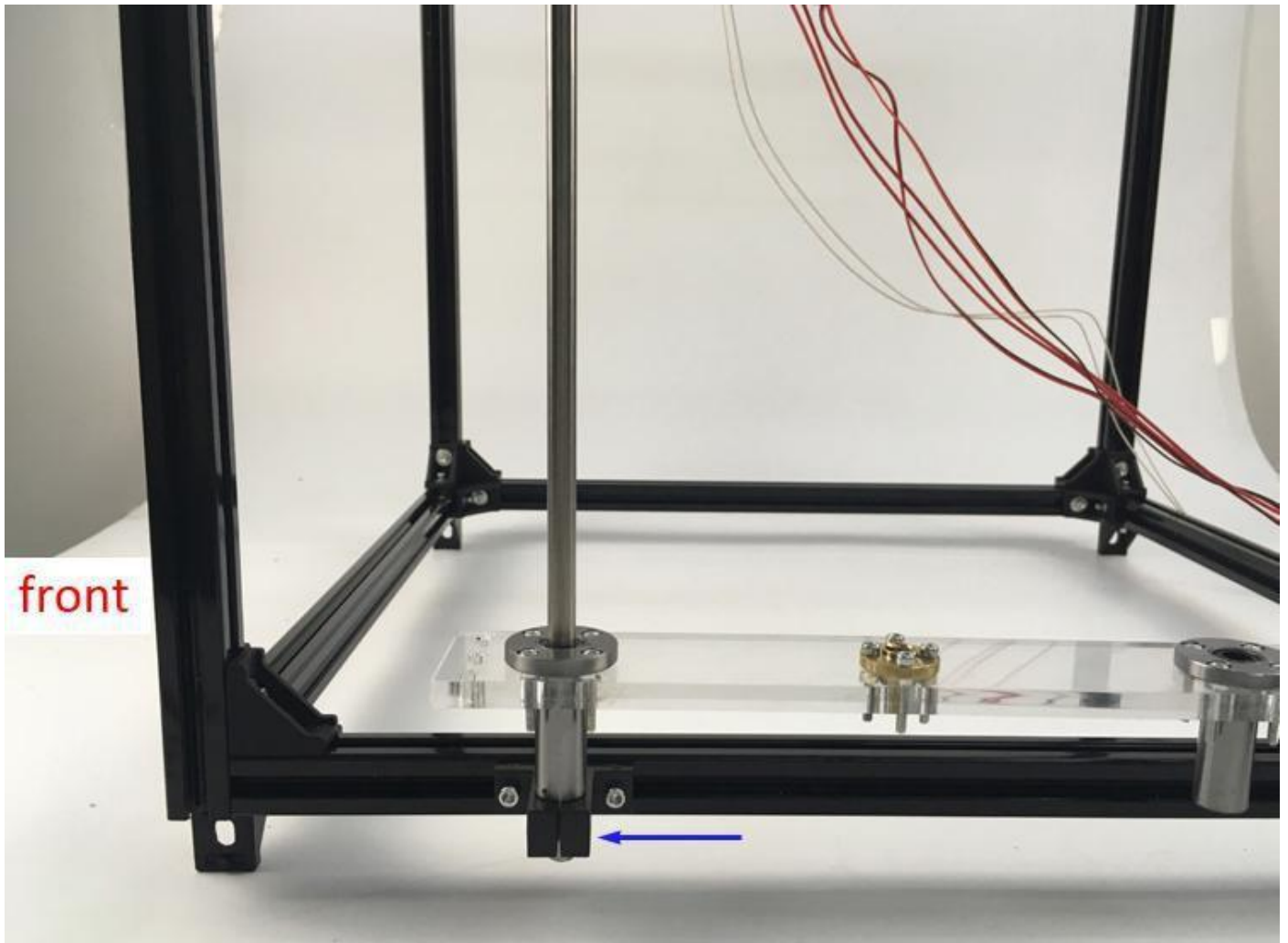

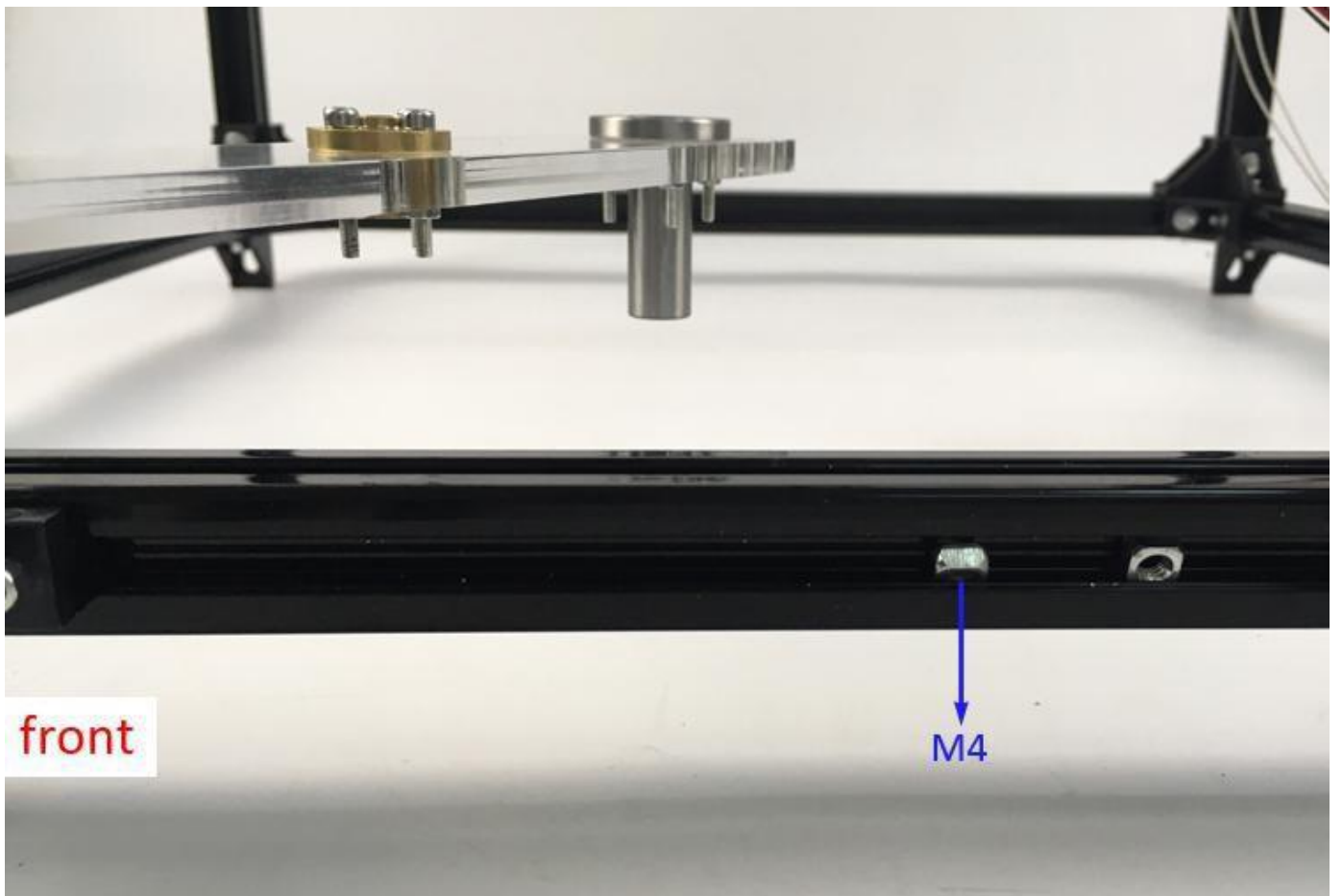
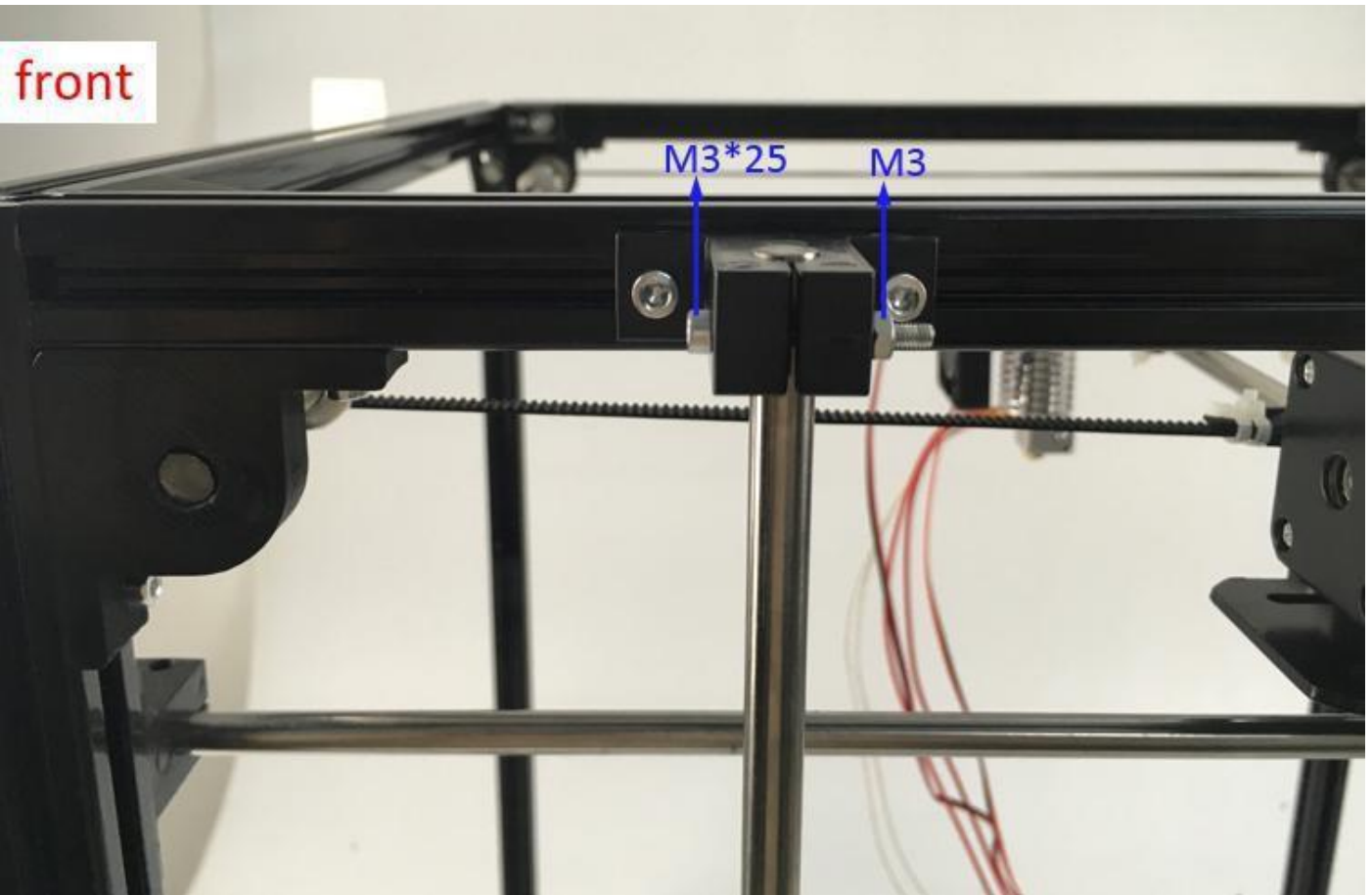

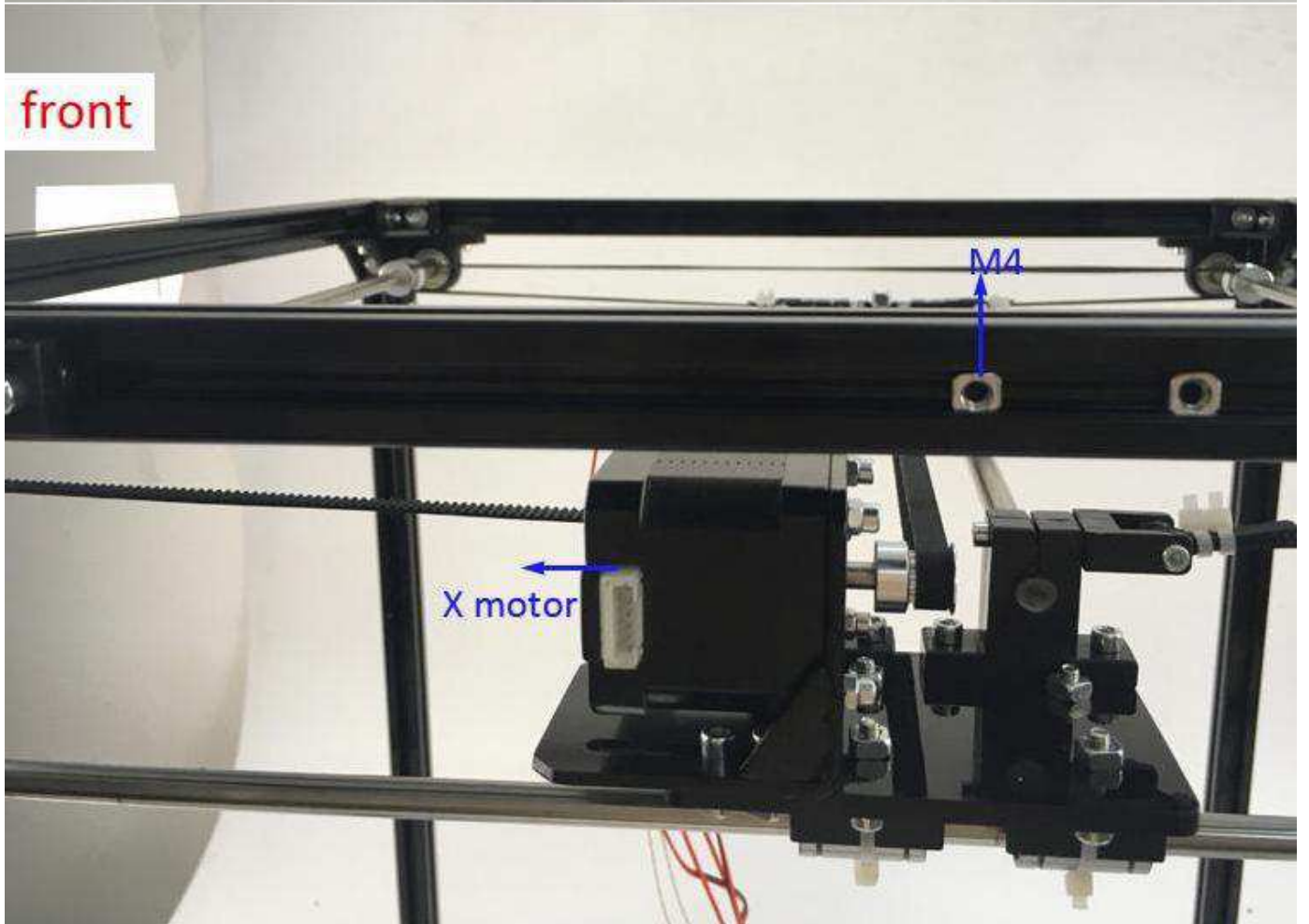
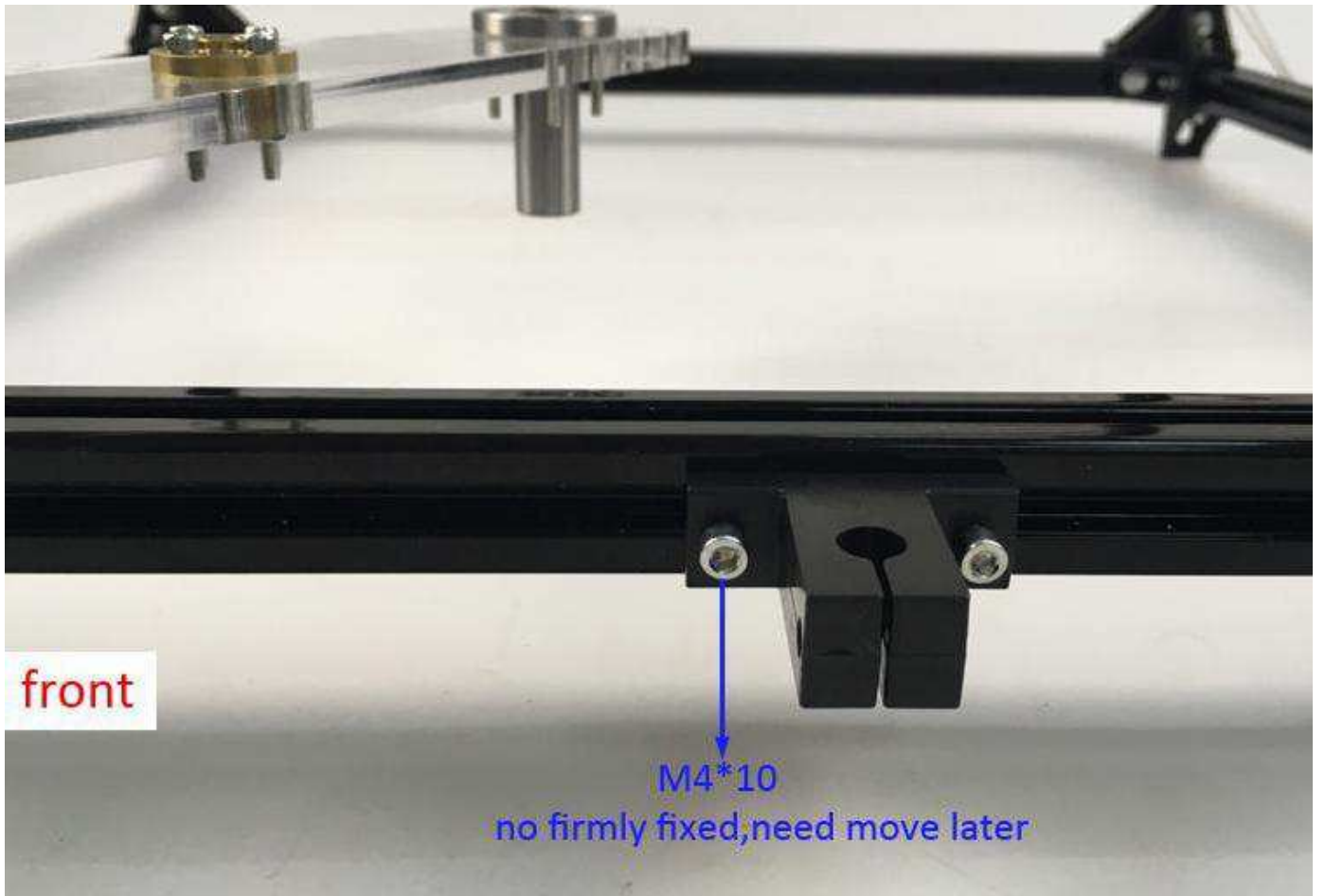



front

no firmly fixed, need move later

M4\*10

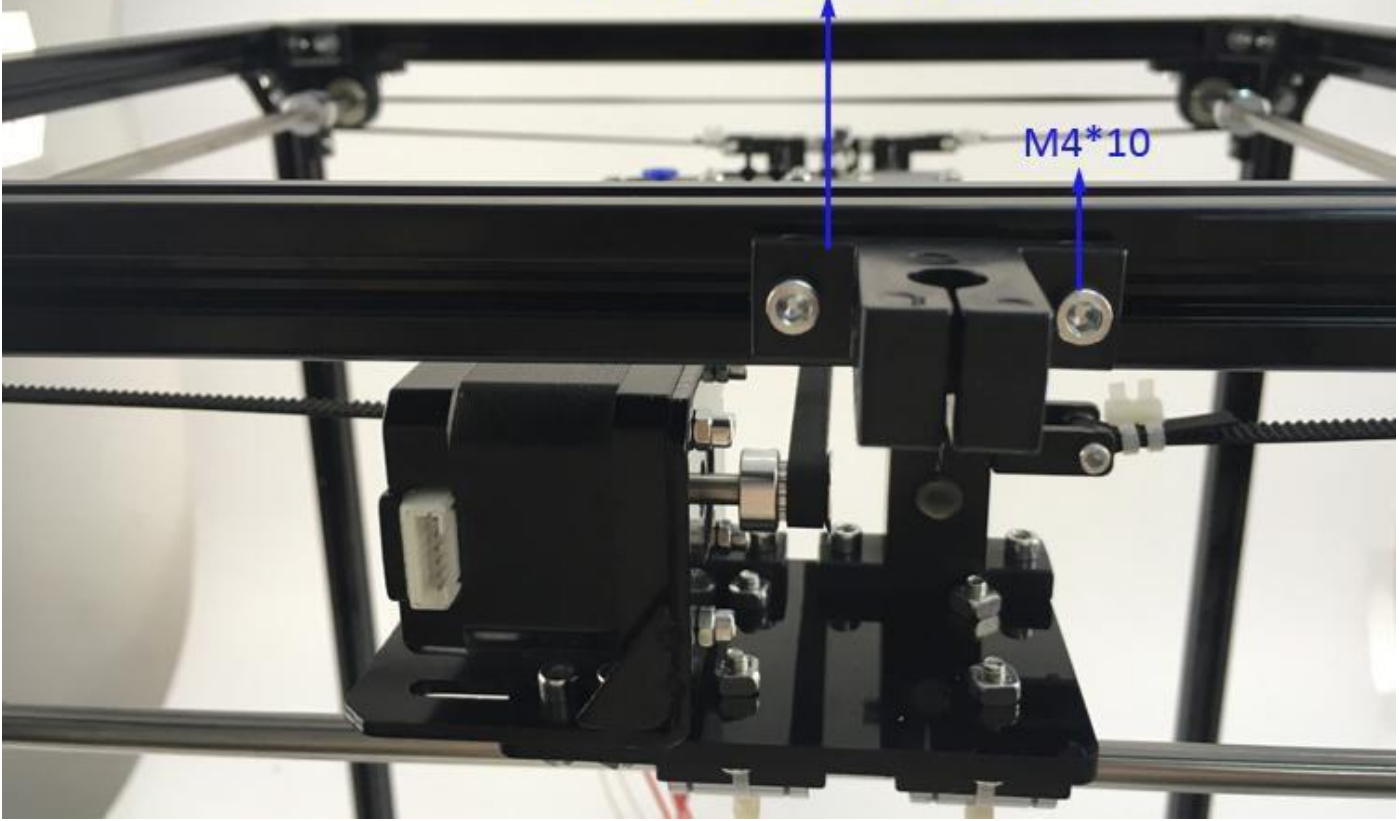

front

push the rod

X motor

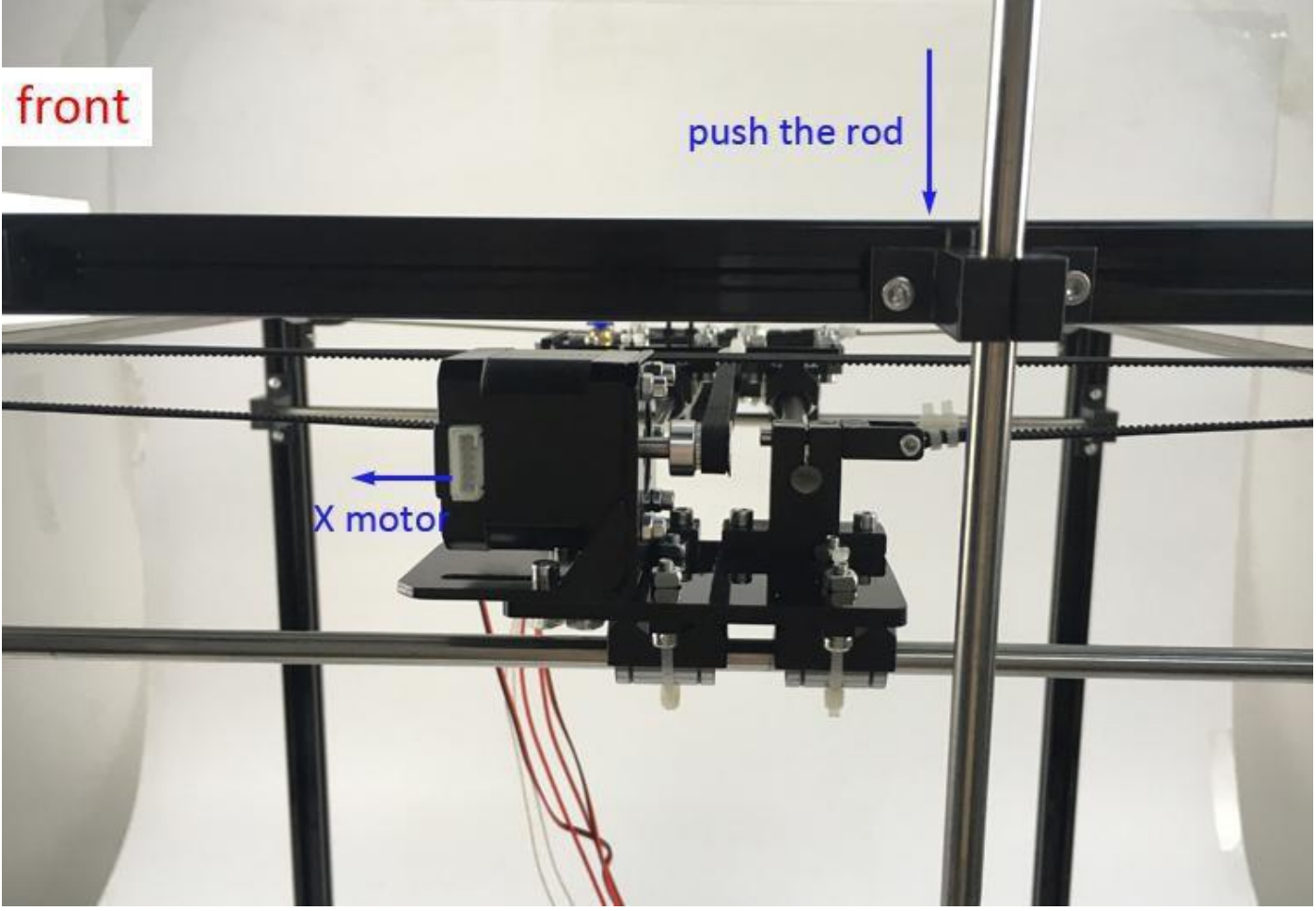

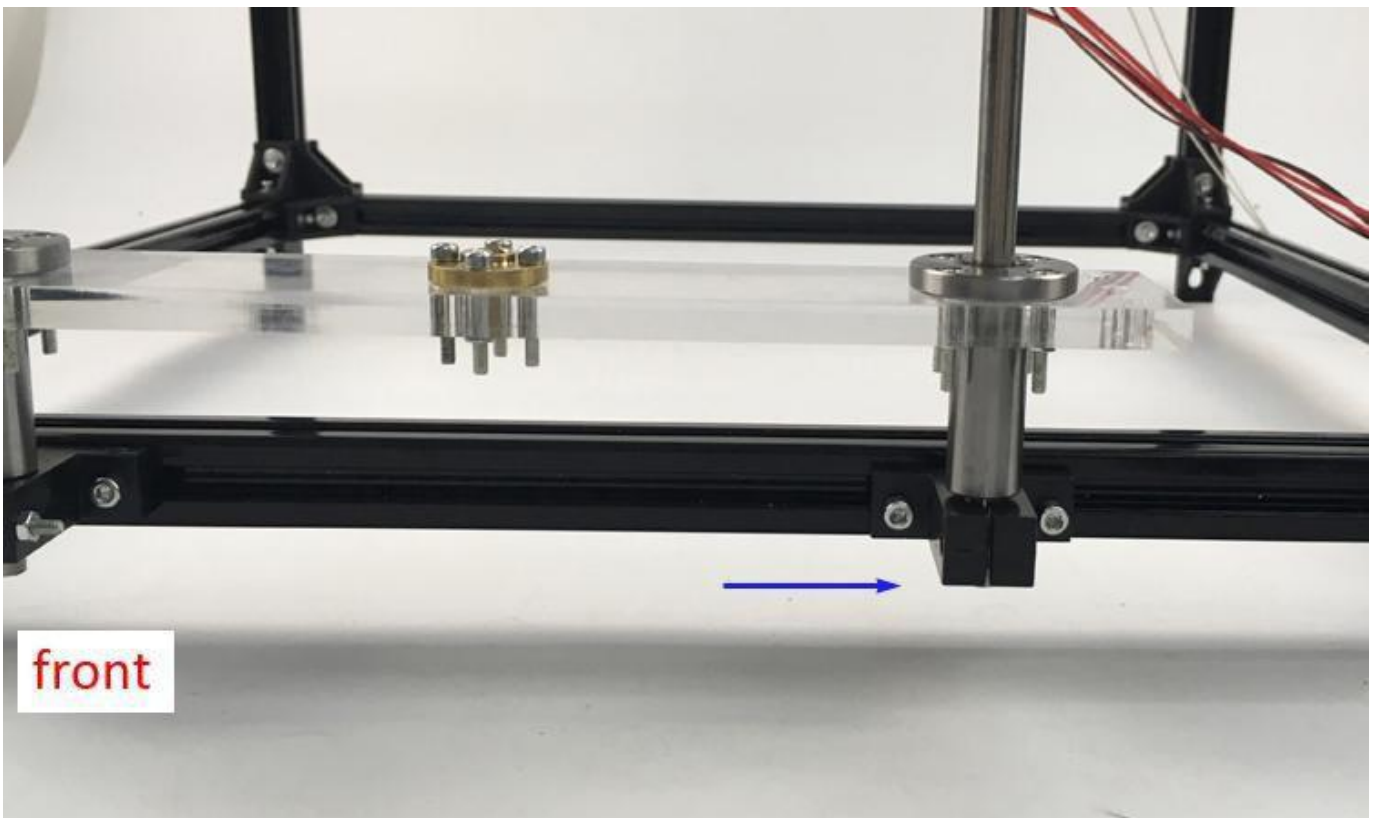
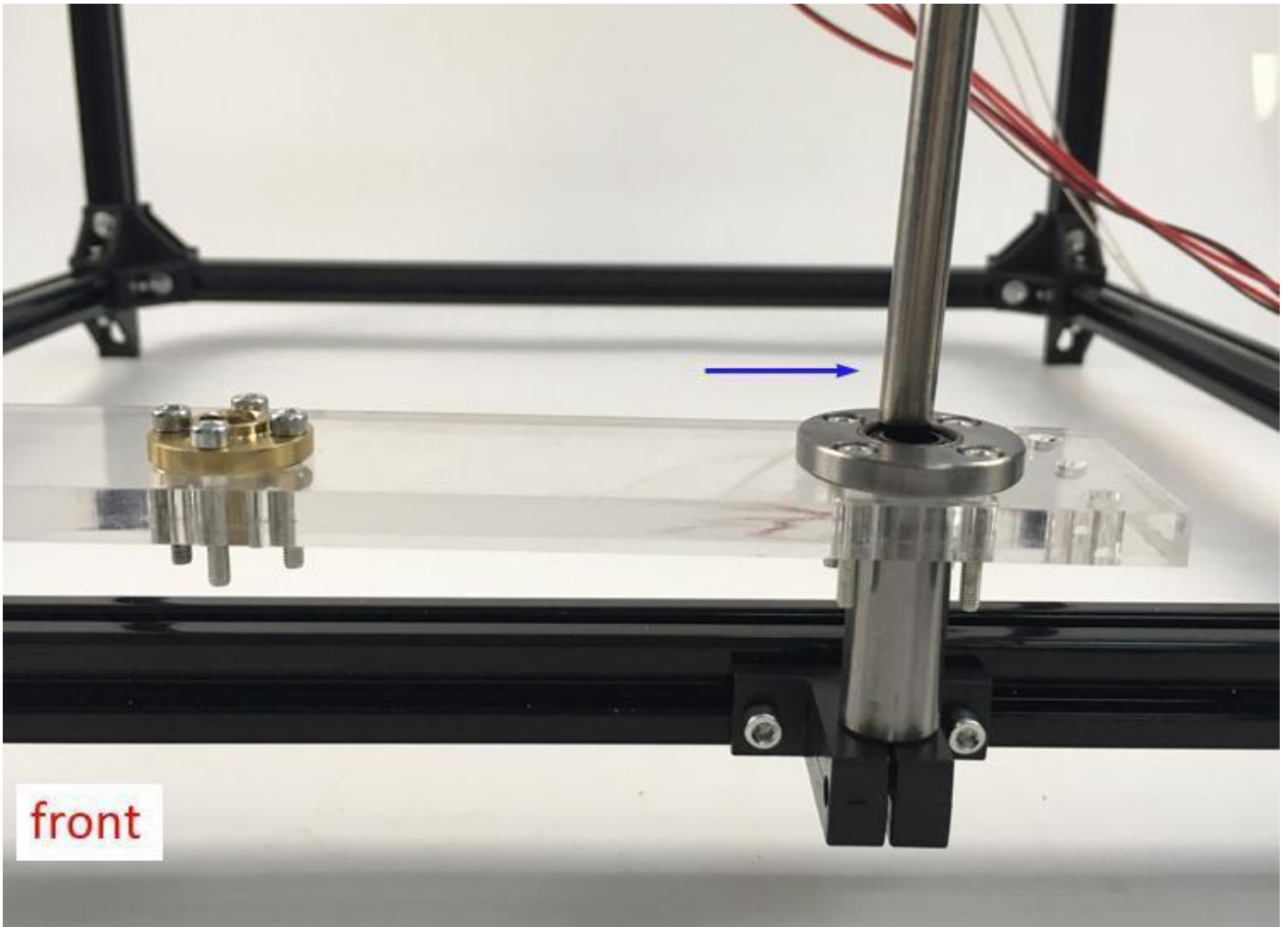

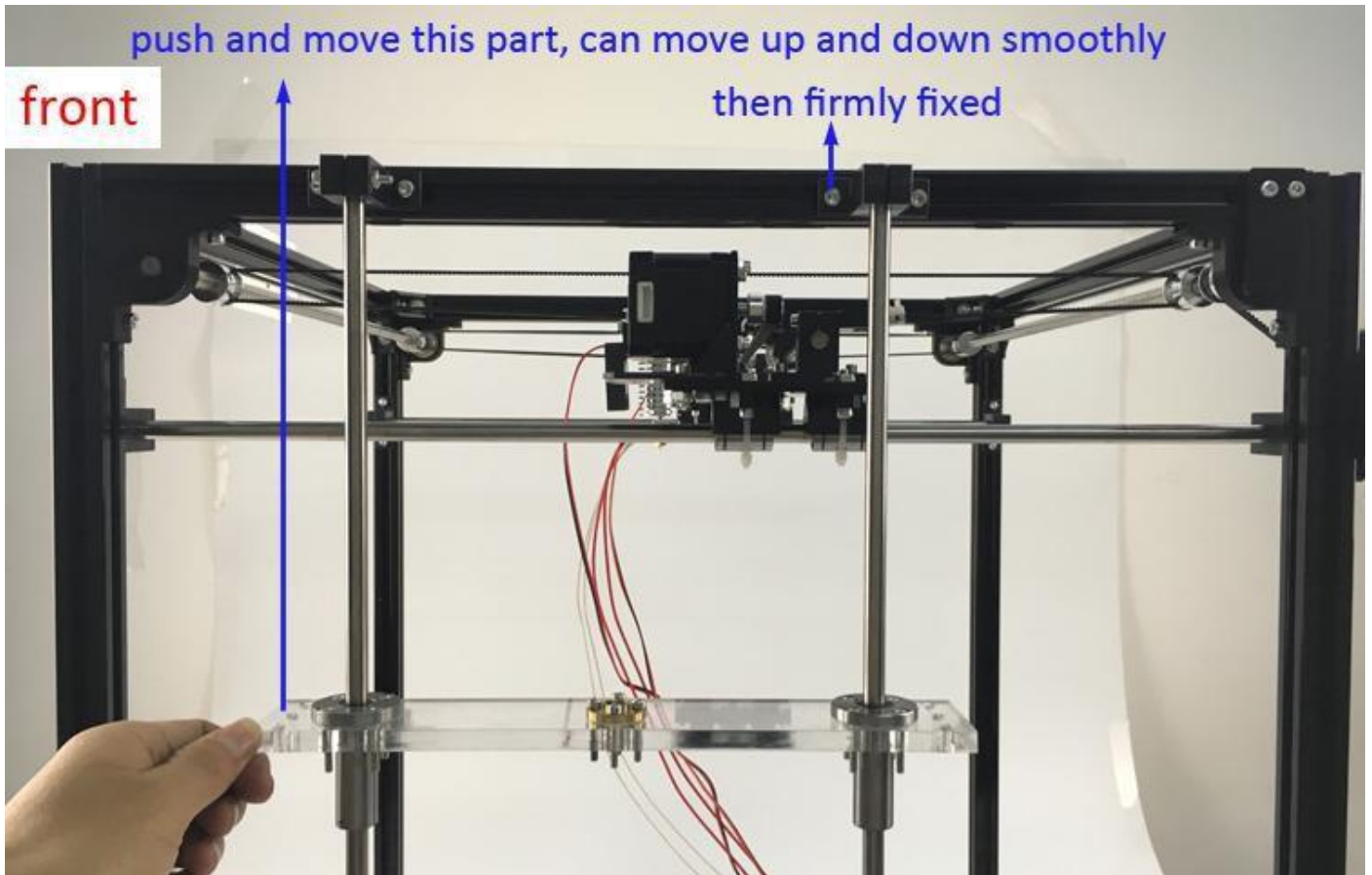
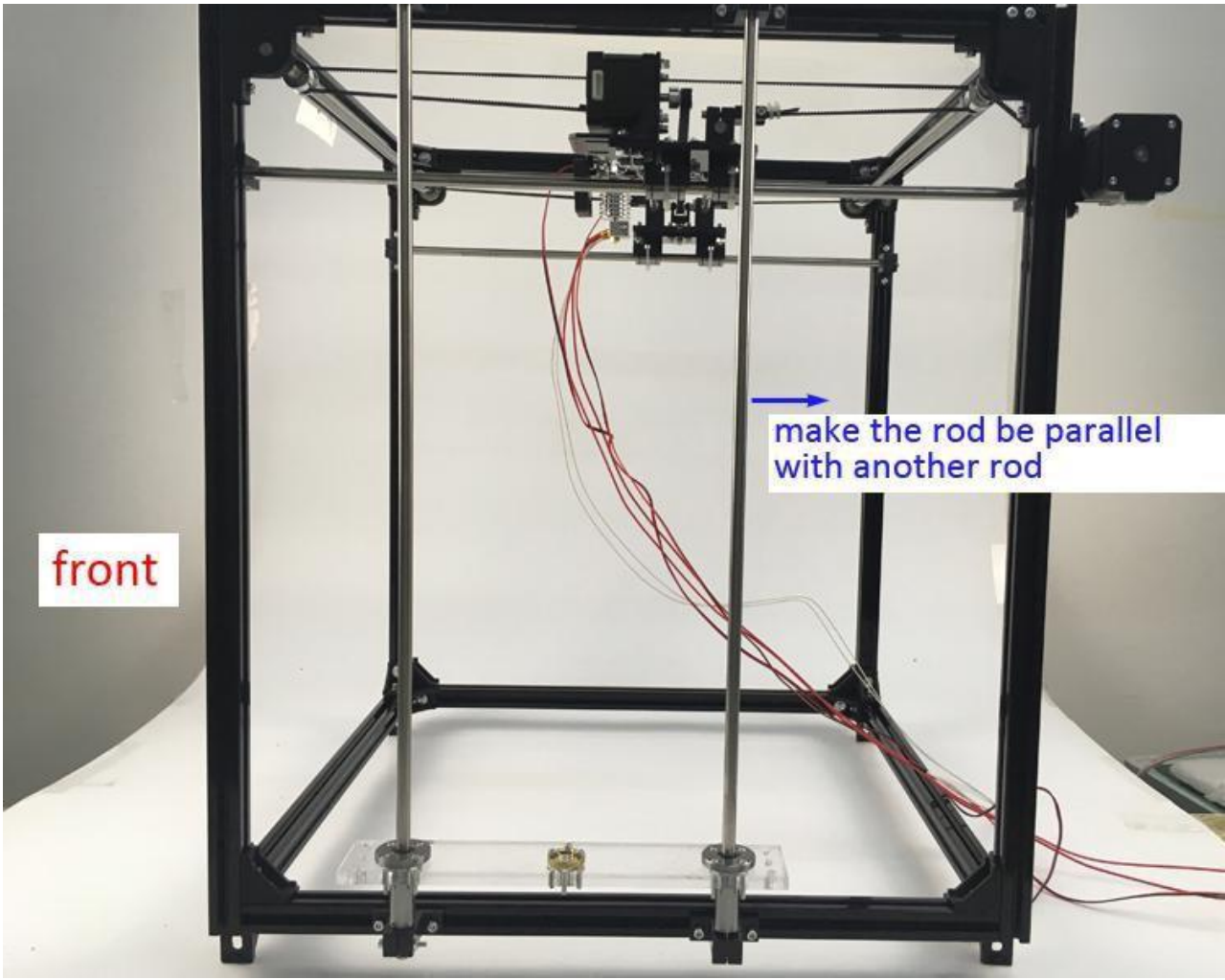

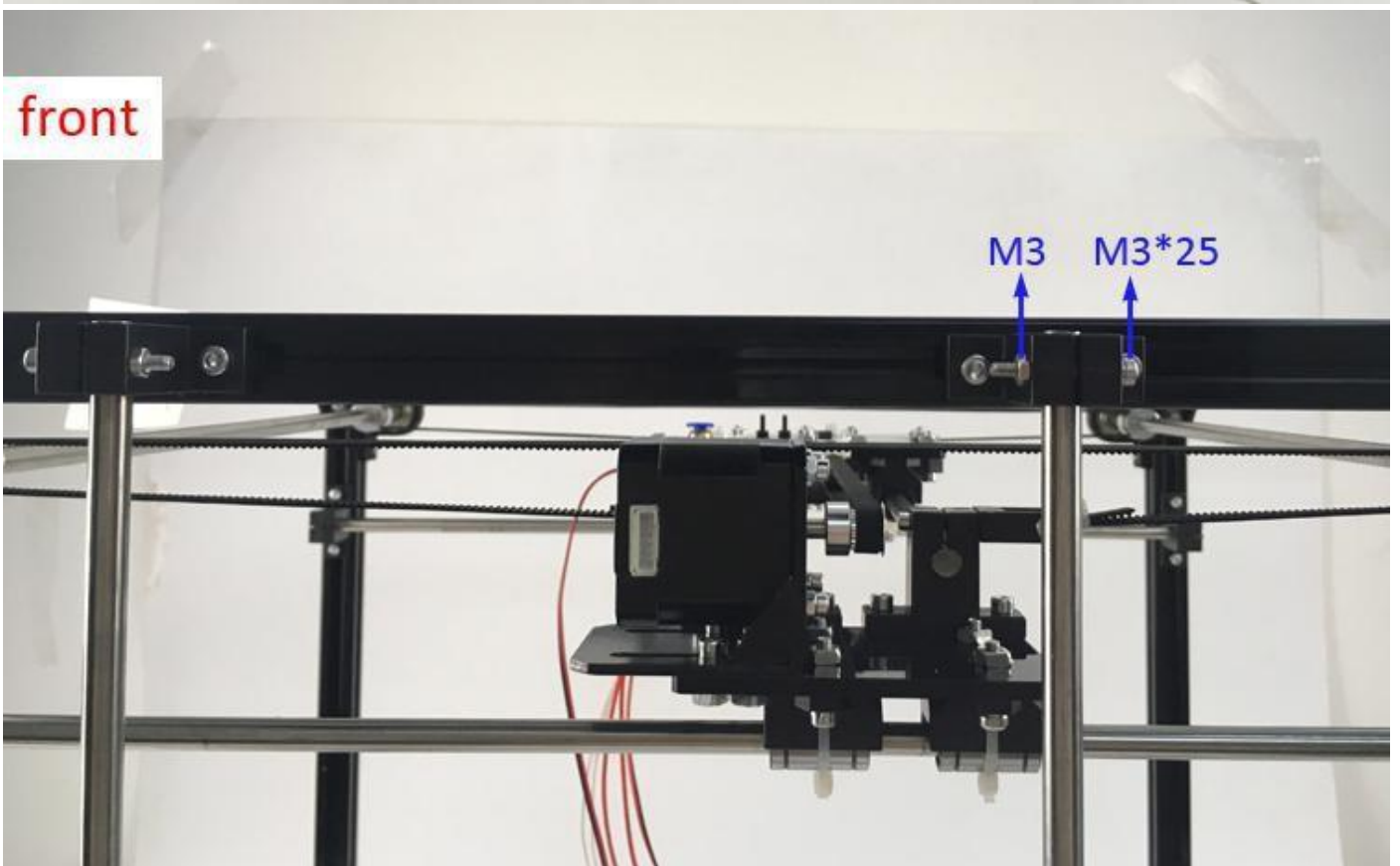
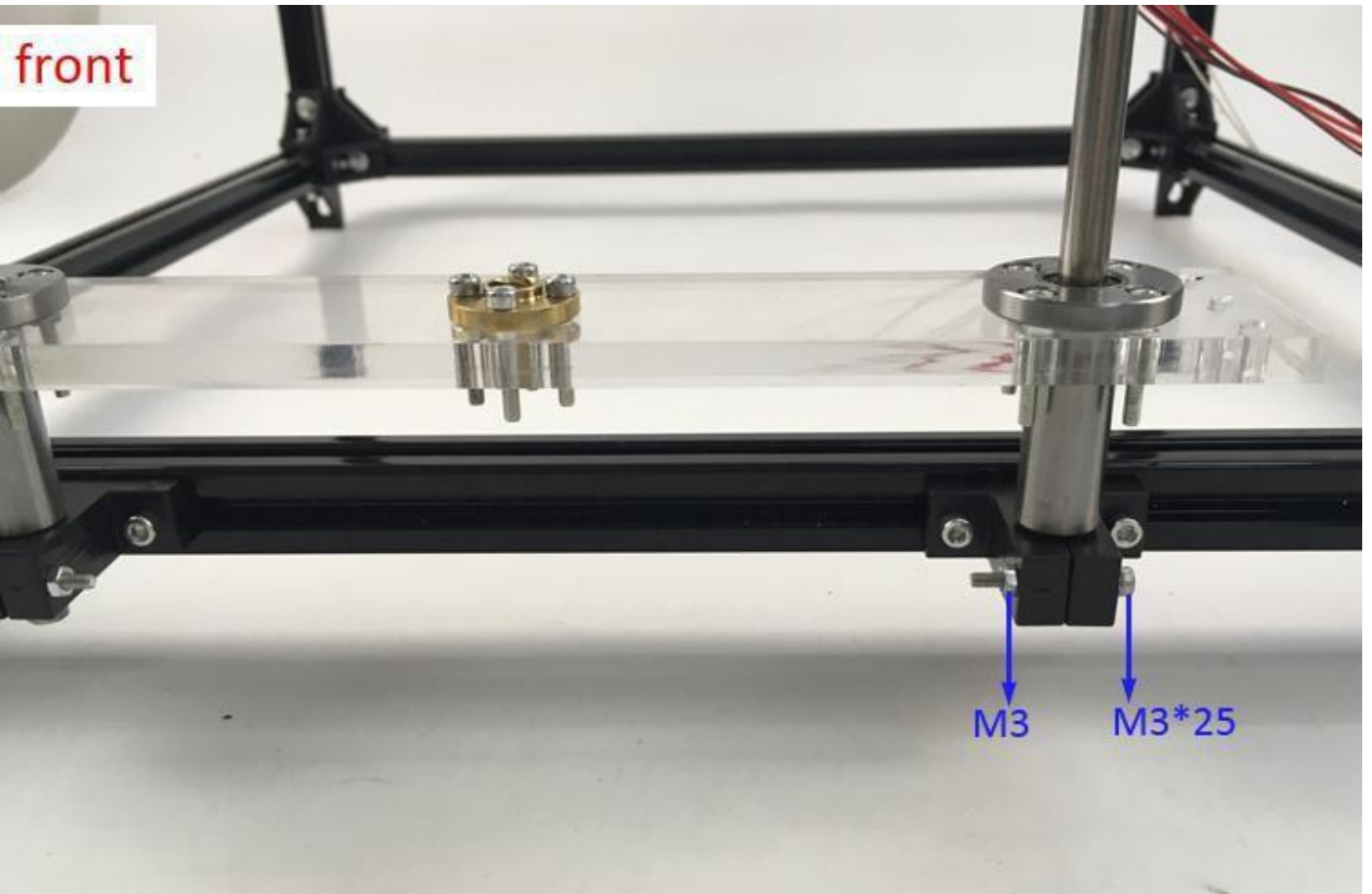

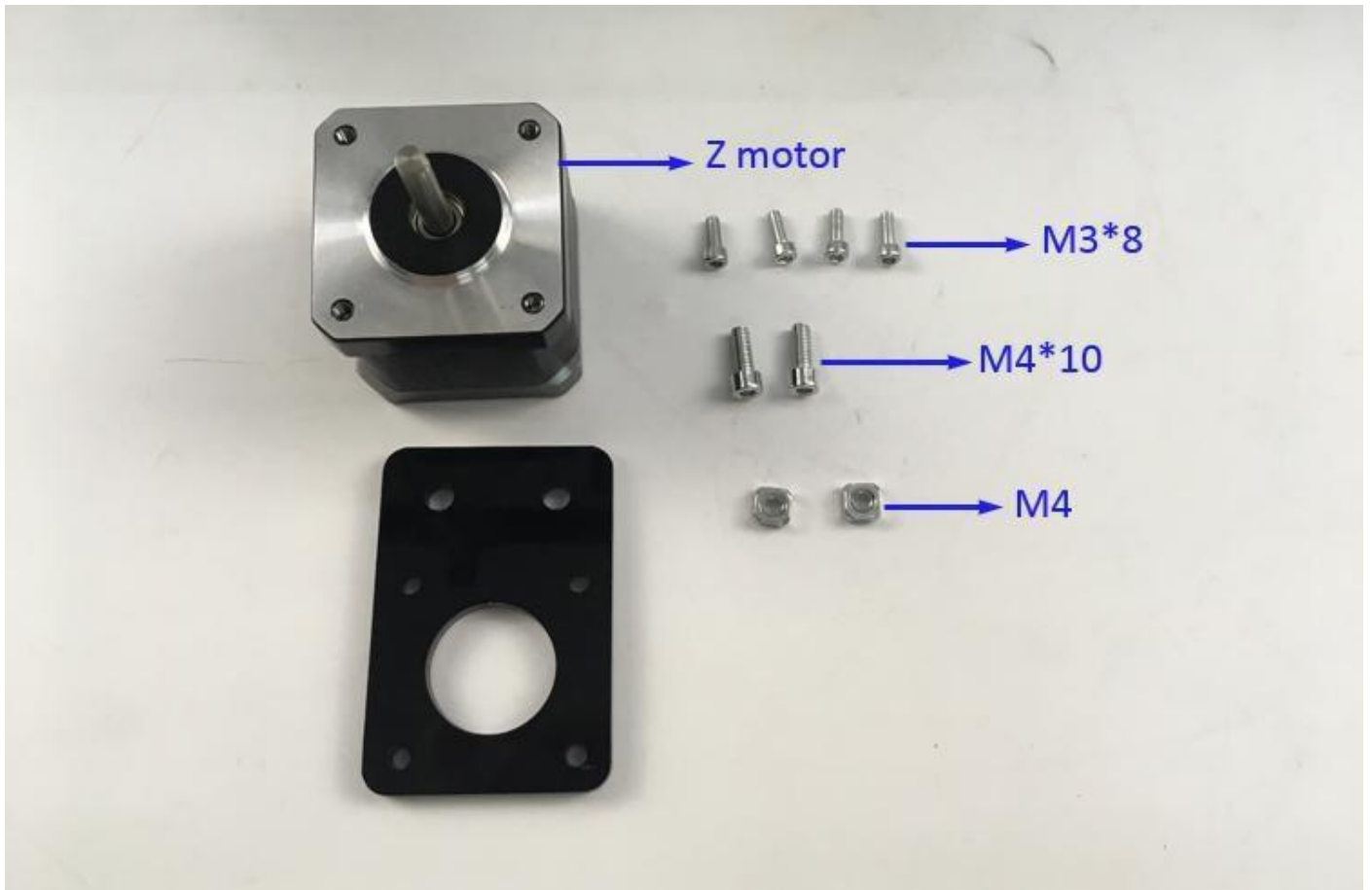

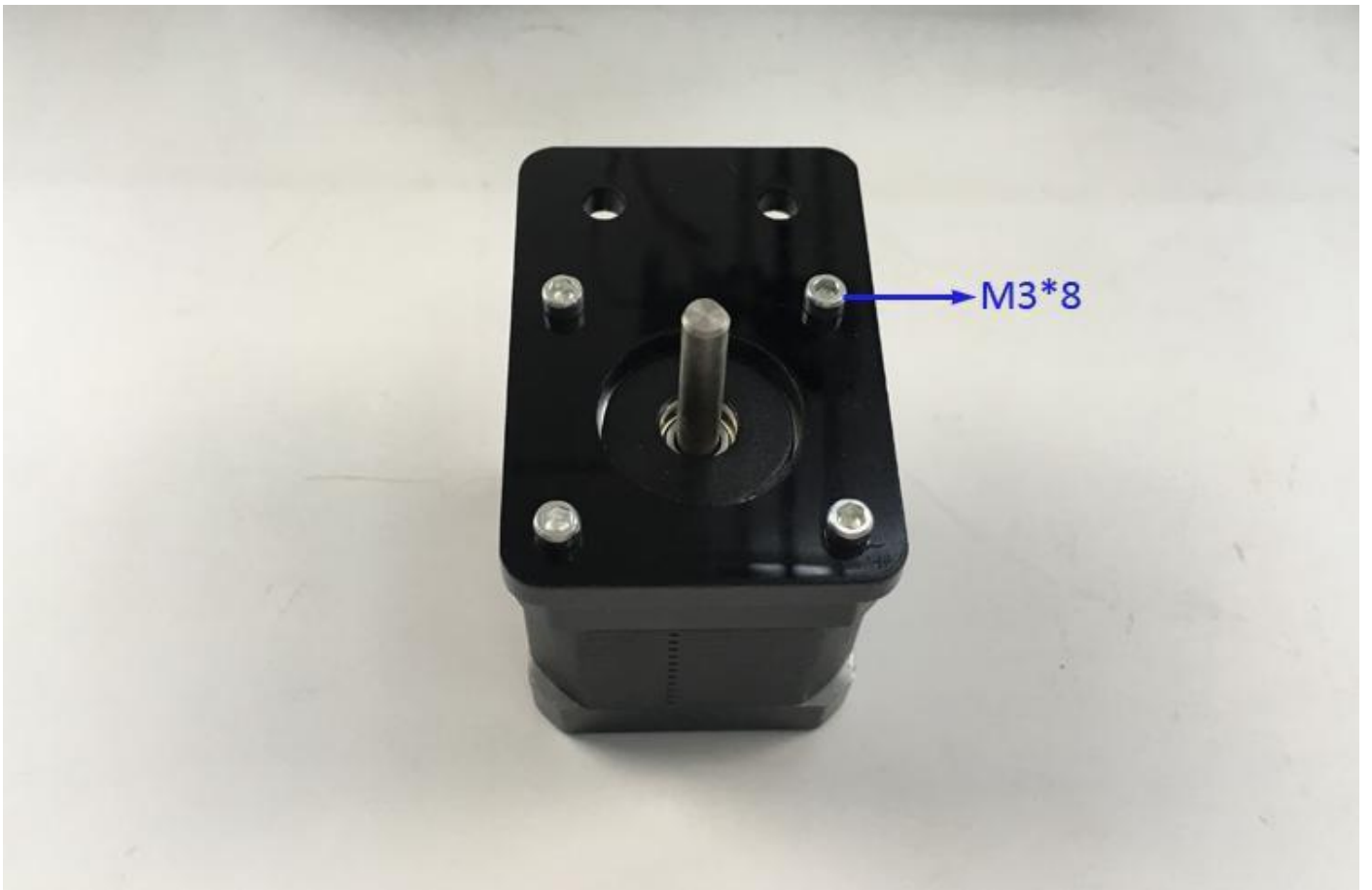

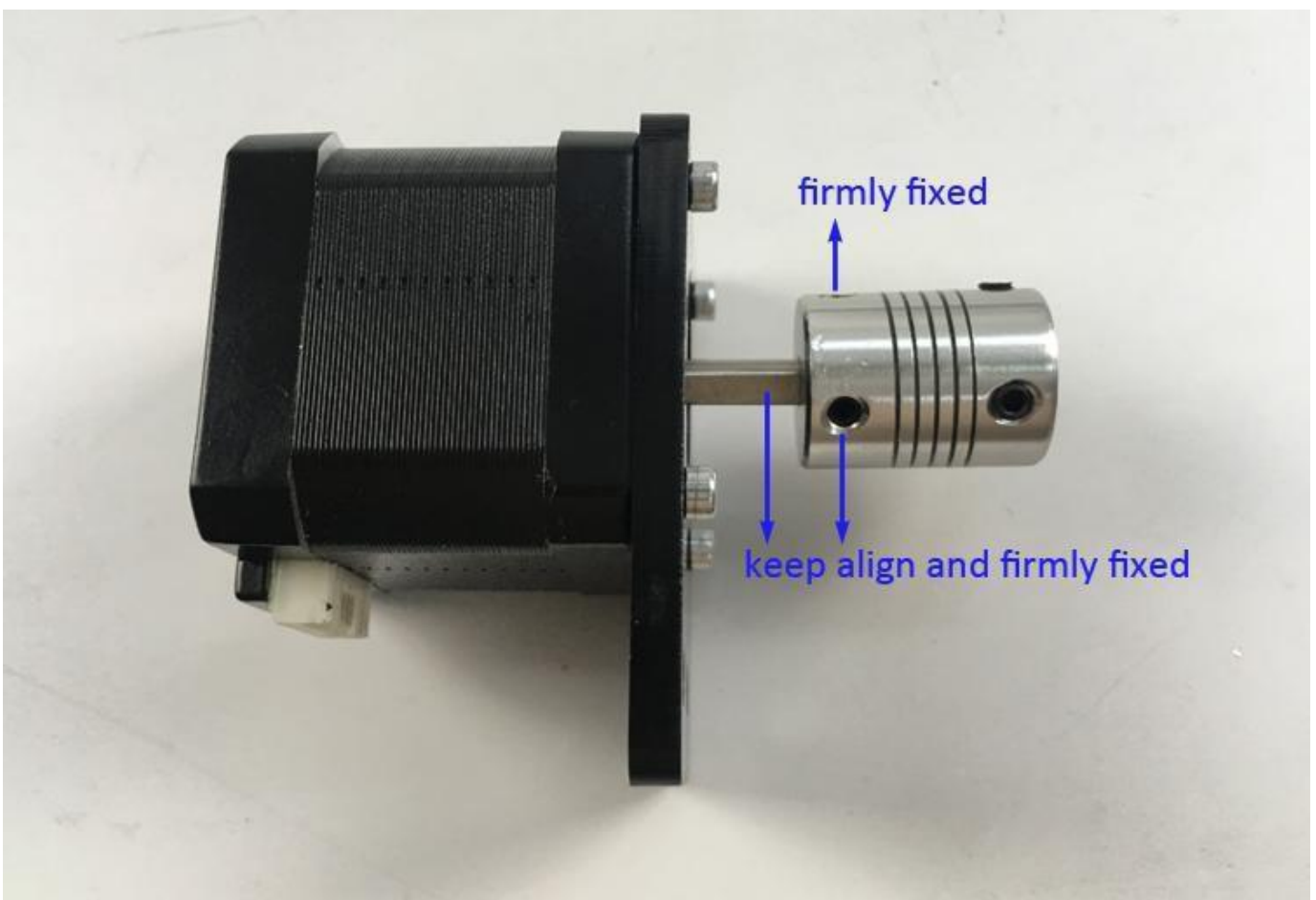
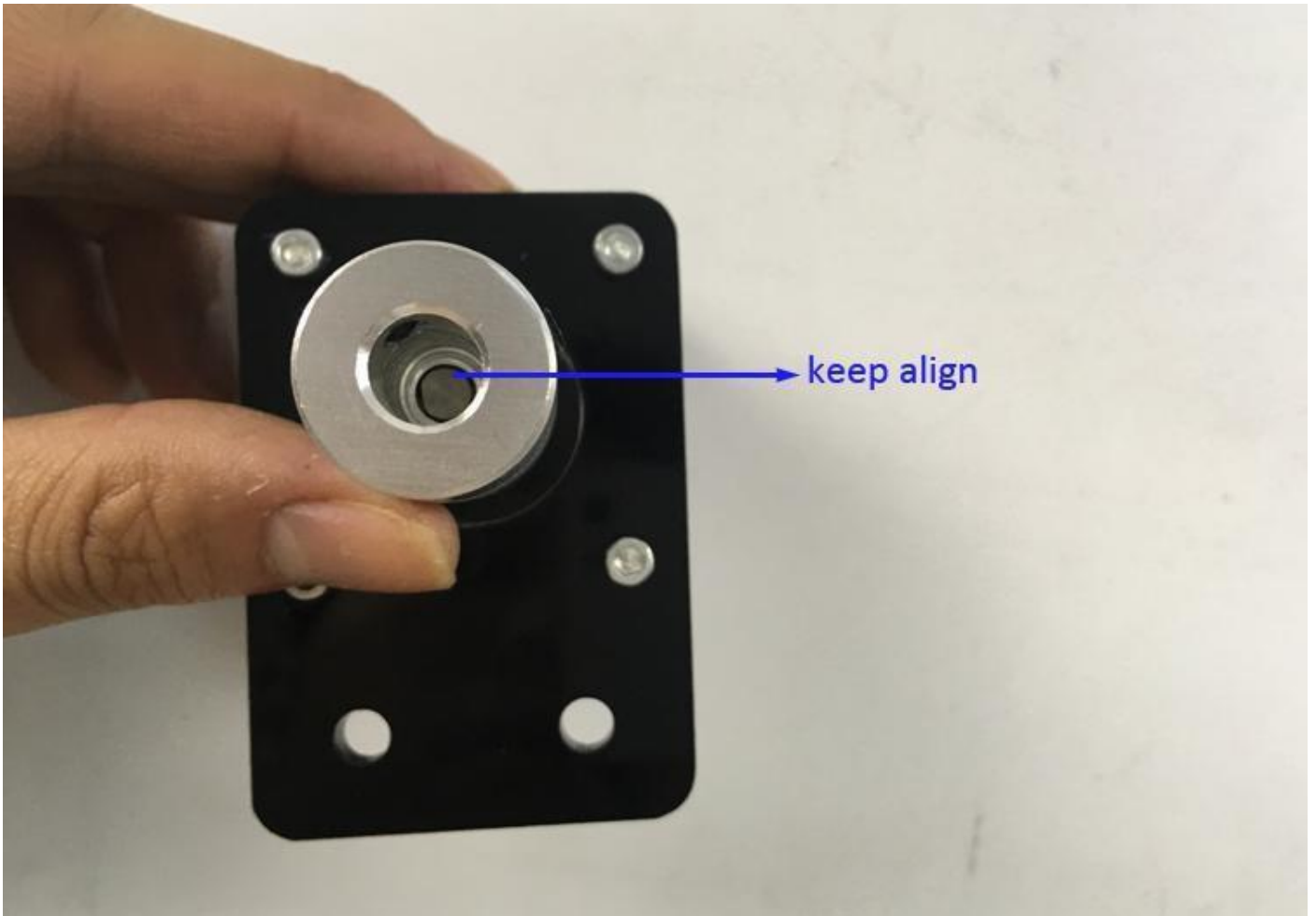

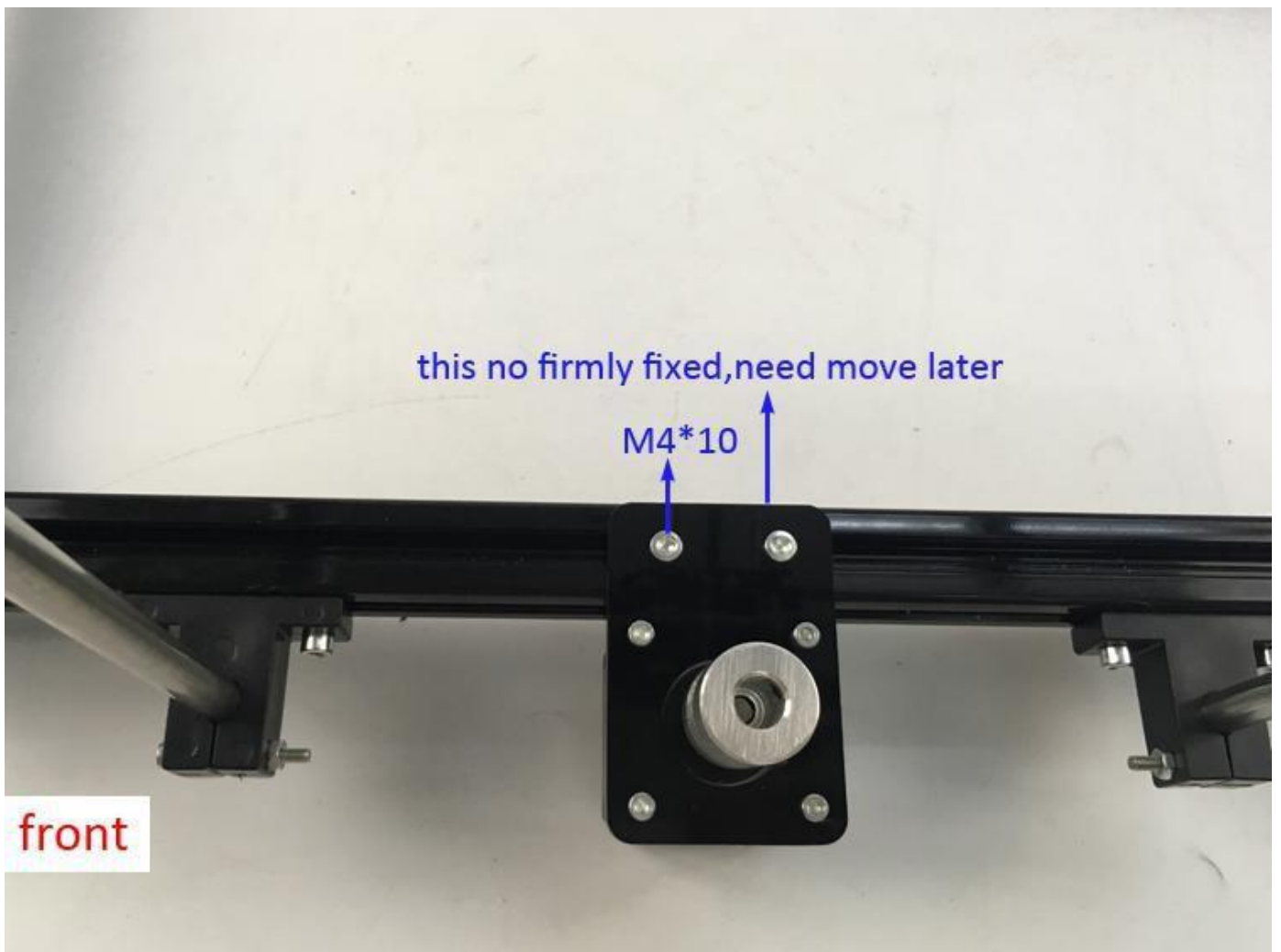
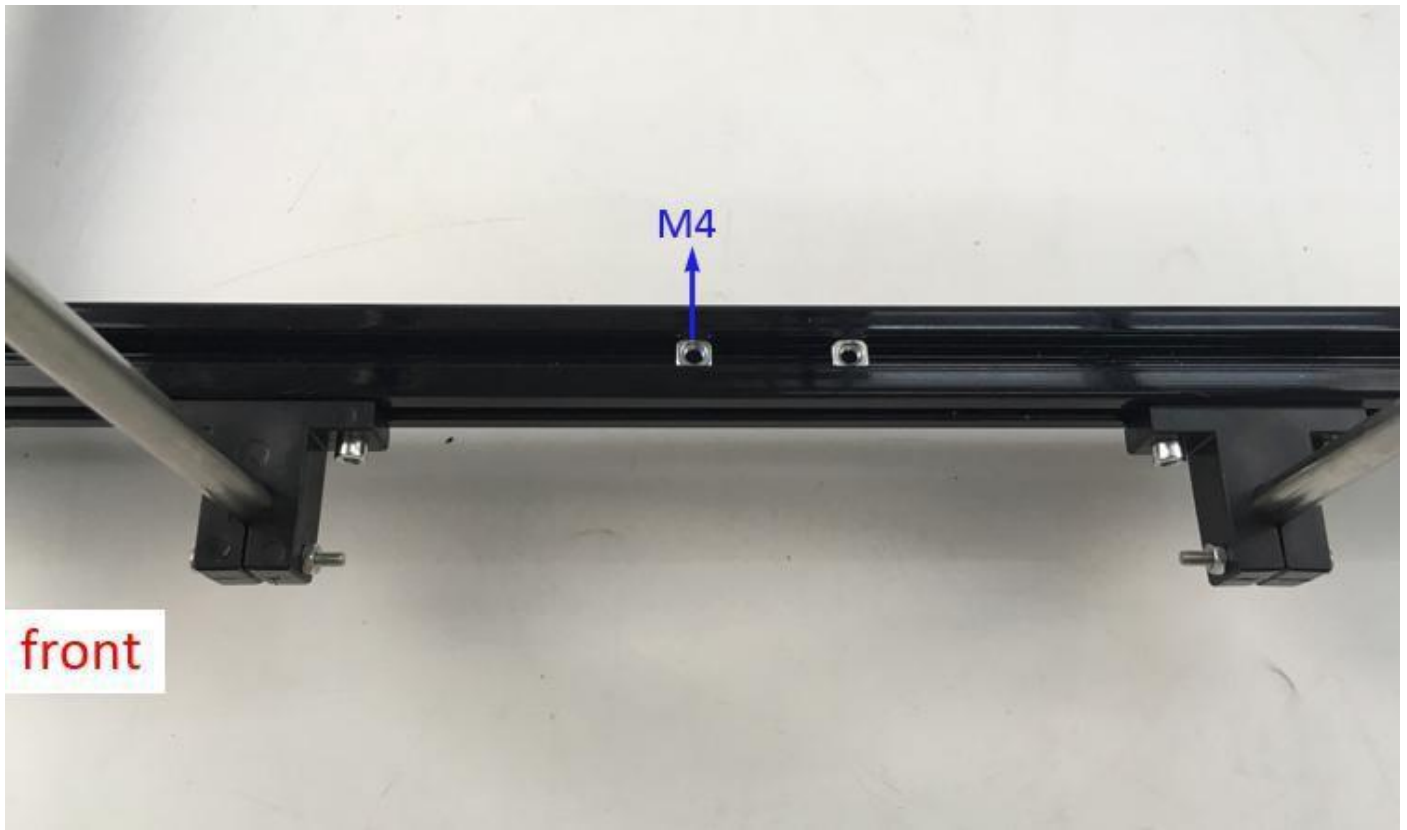



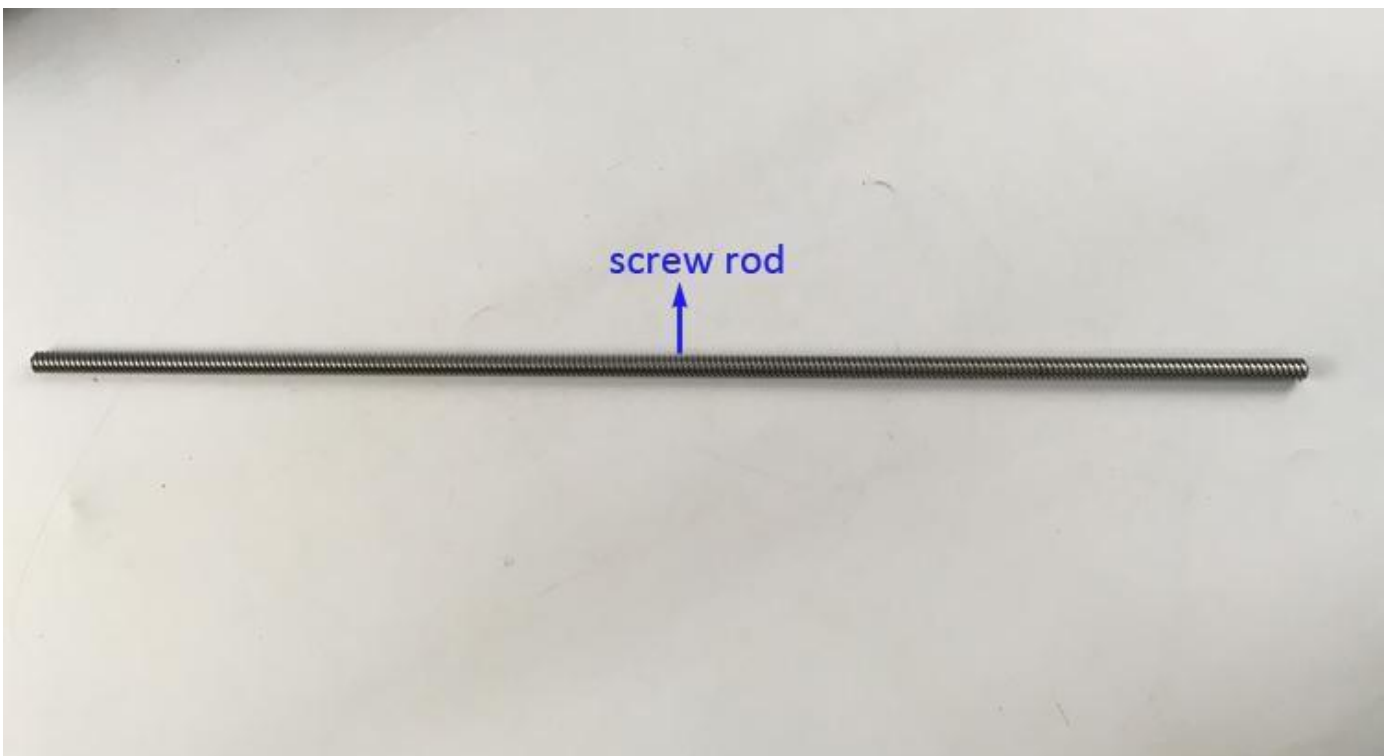
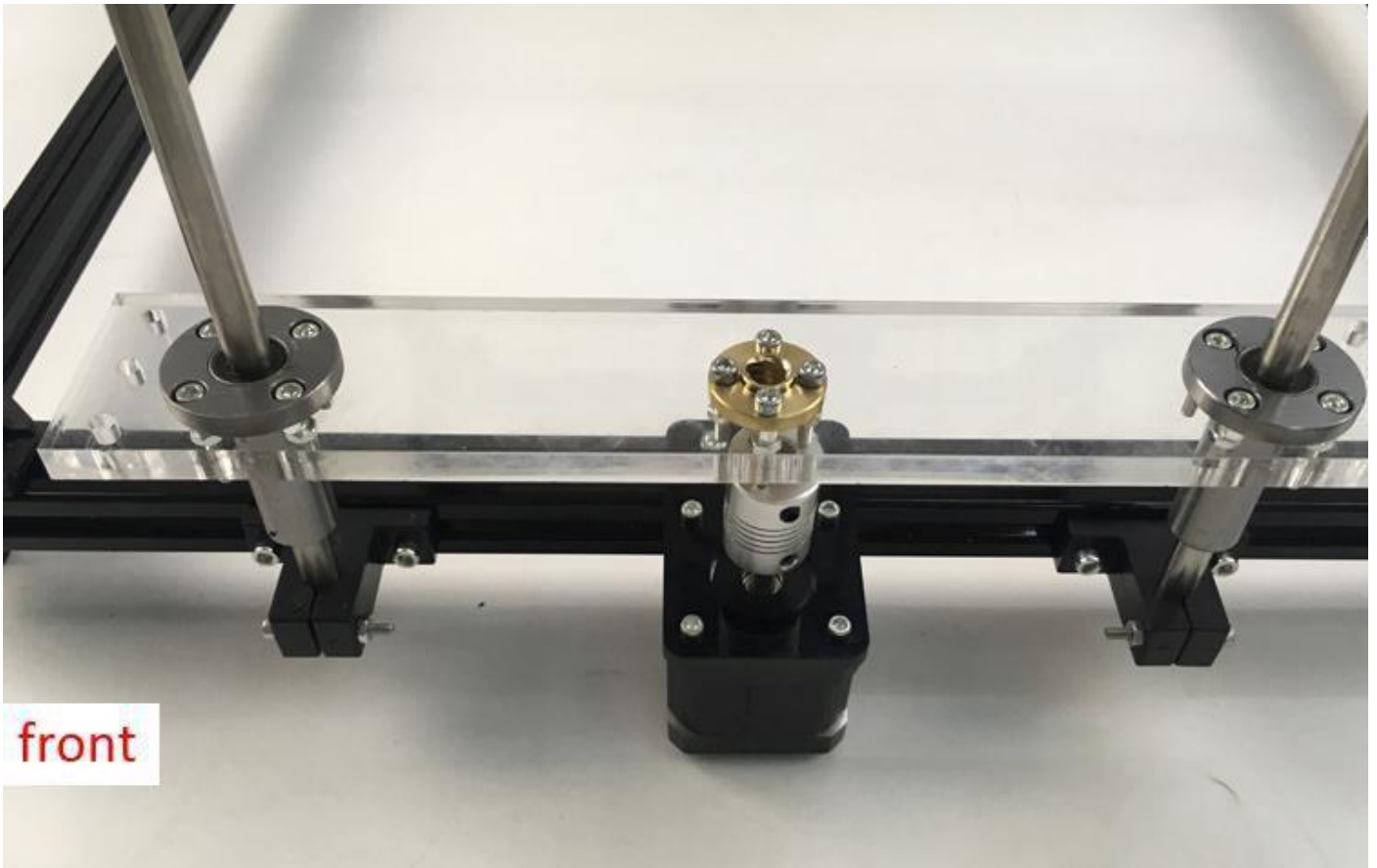

front

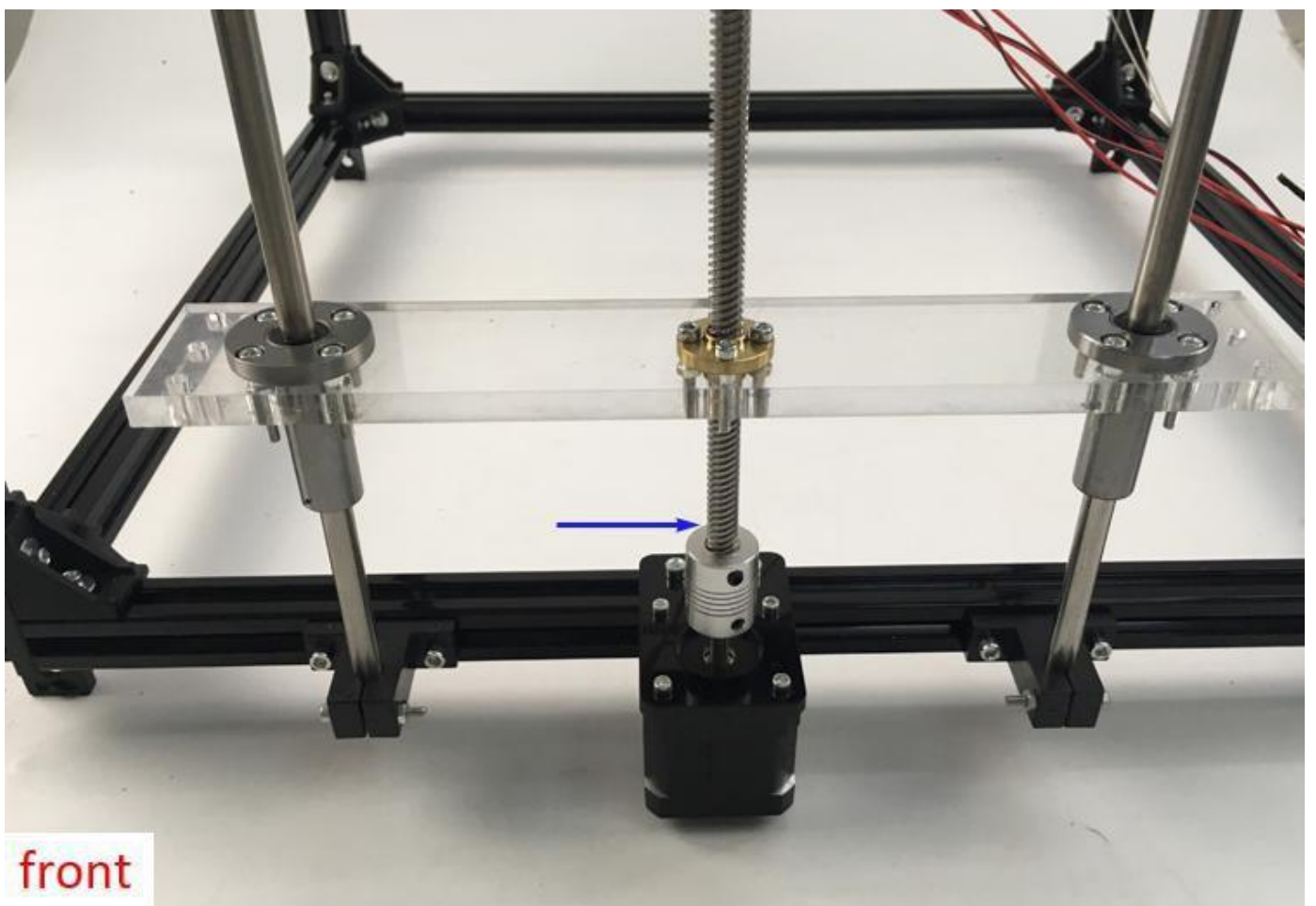
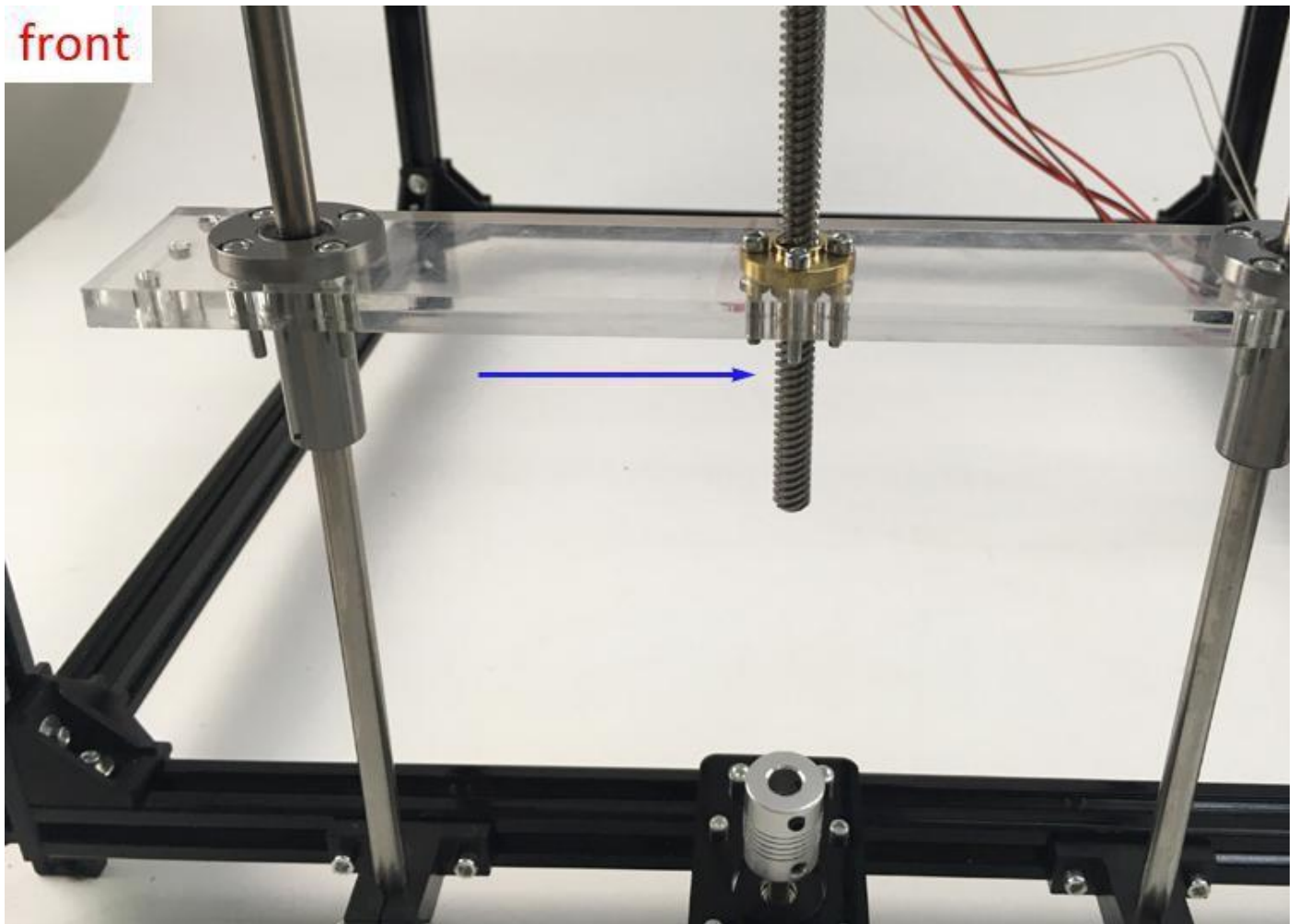

front

move the motor to make the screw rod be vertical, that is to say, 1 and 2 can be in one same straight line

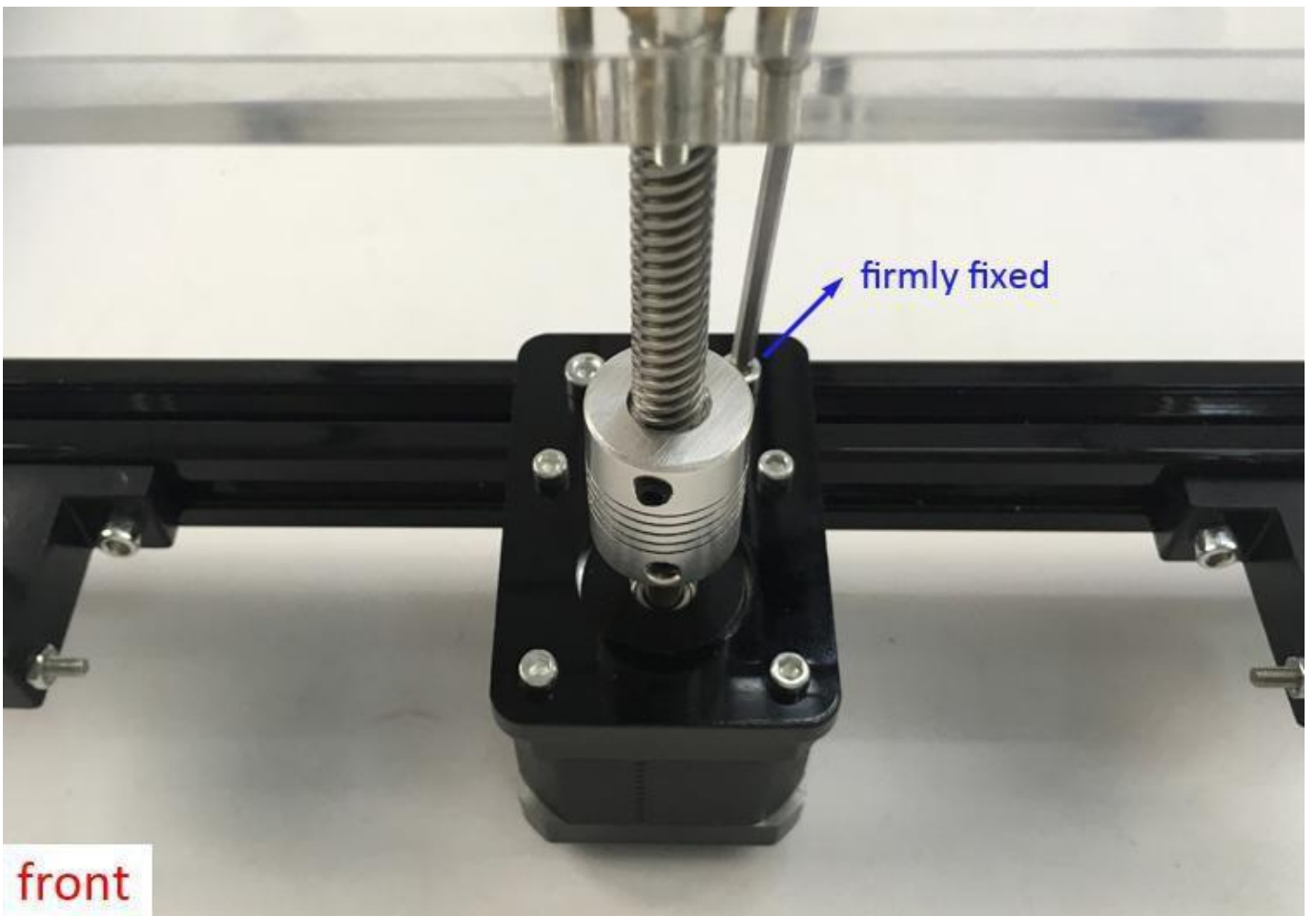
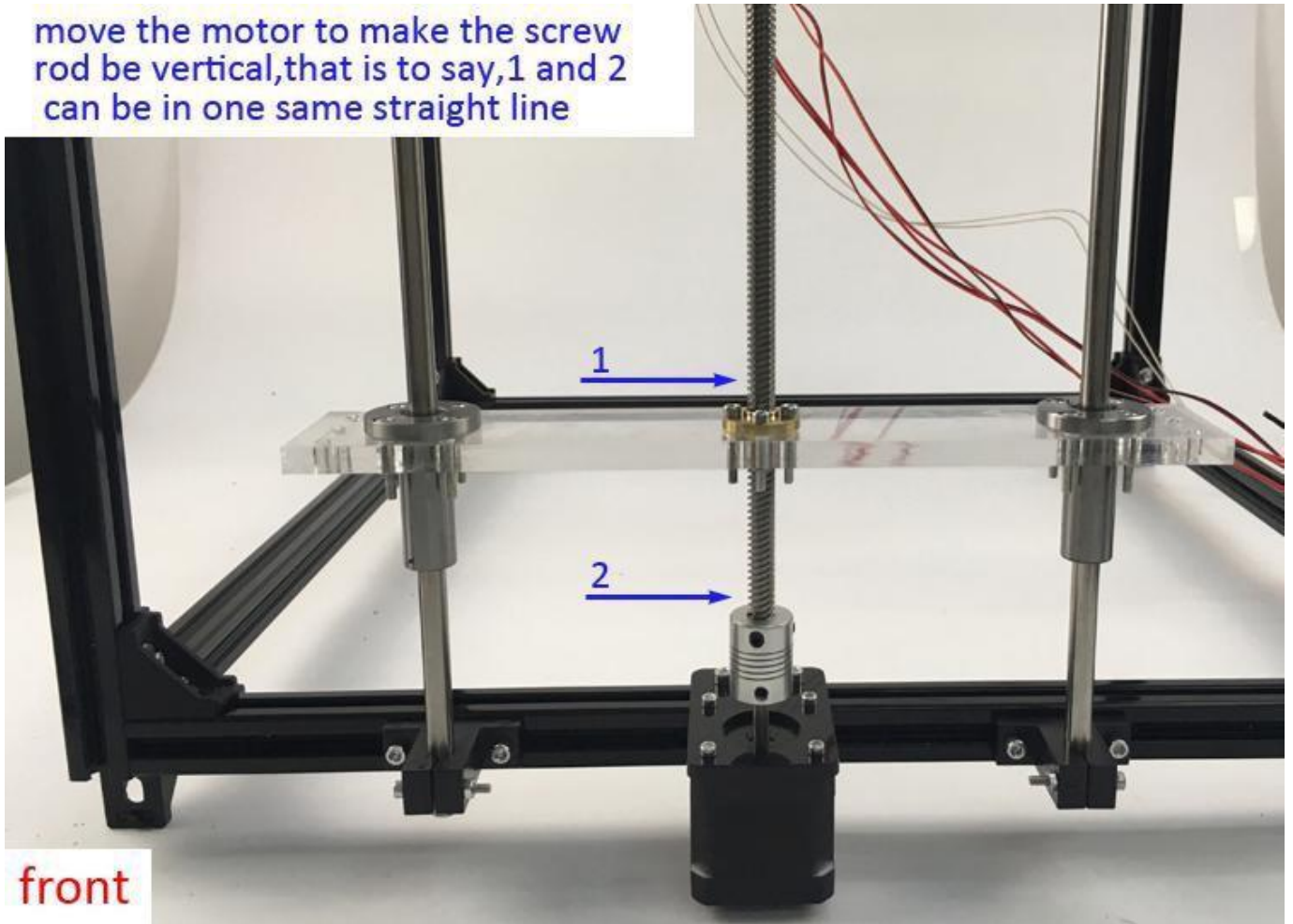

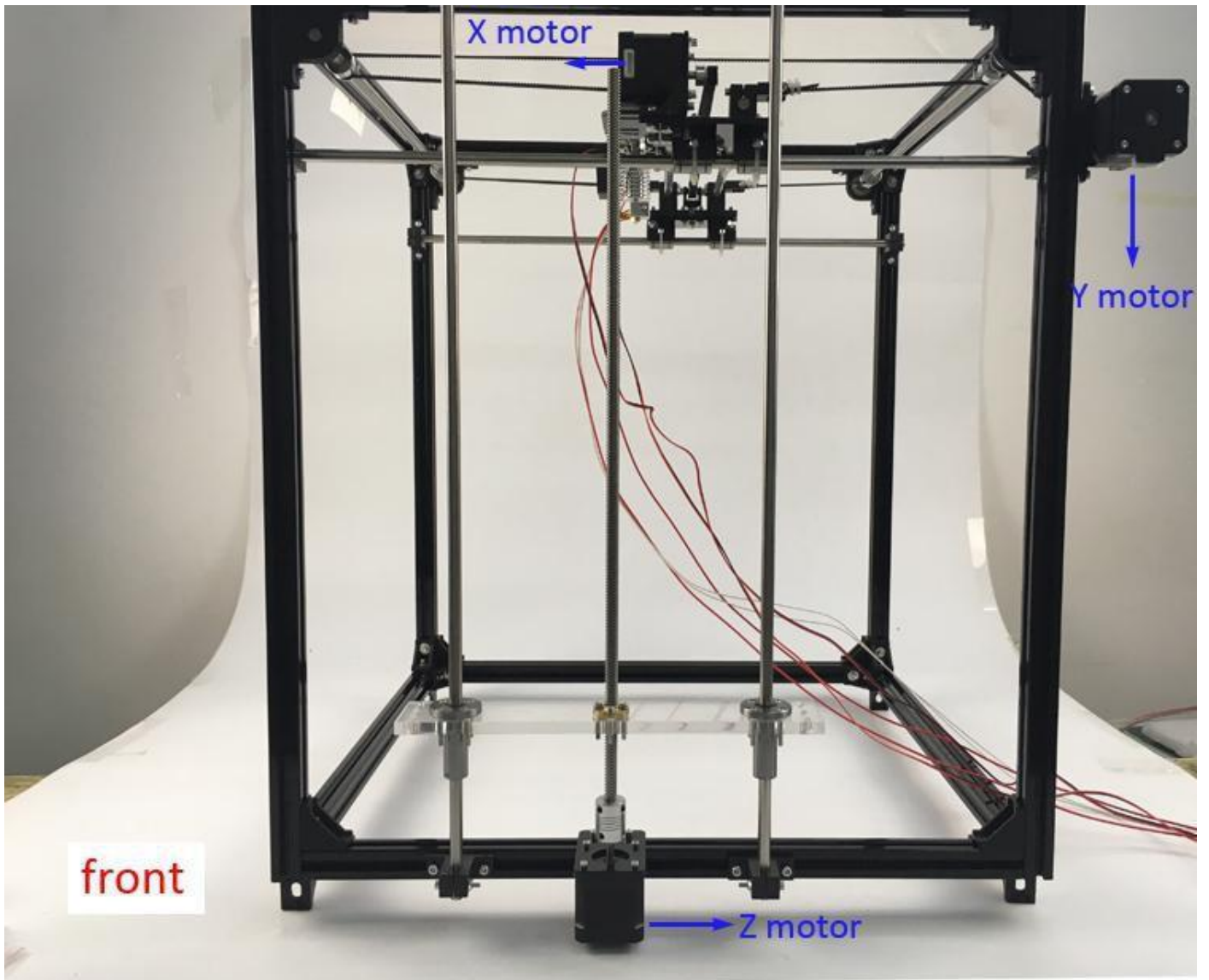

rotate the machine 180 °,assembly another Z axis.  
as before definy,the right is front.

this Z axis is same with another one,the assembly way is same,  
here only show some key points.

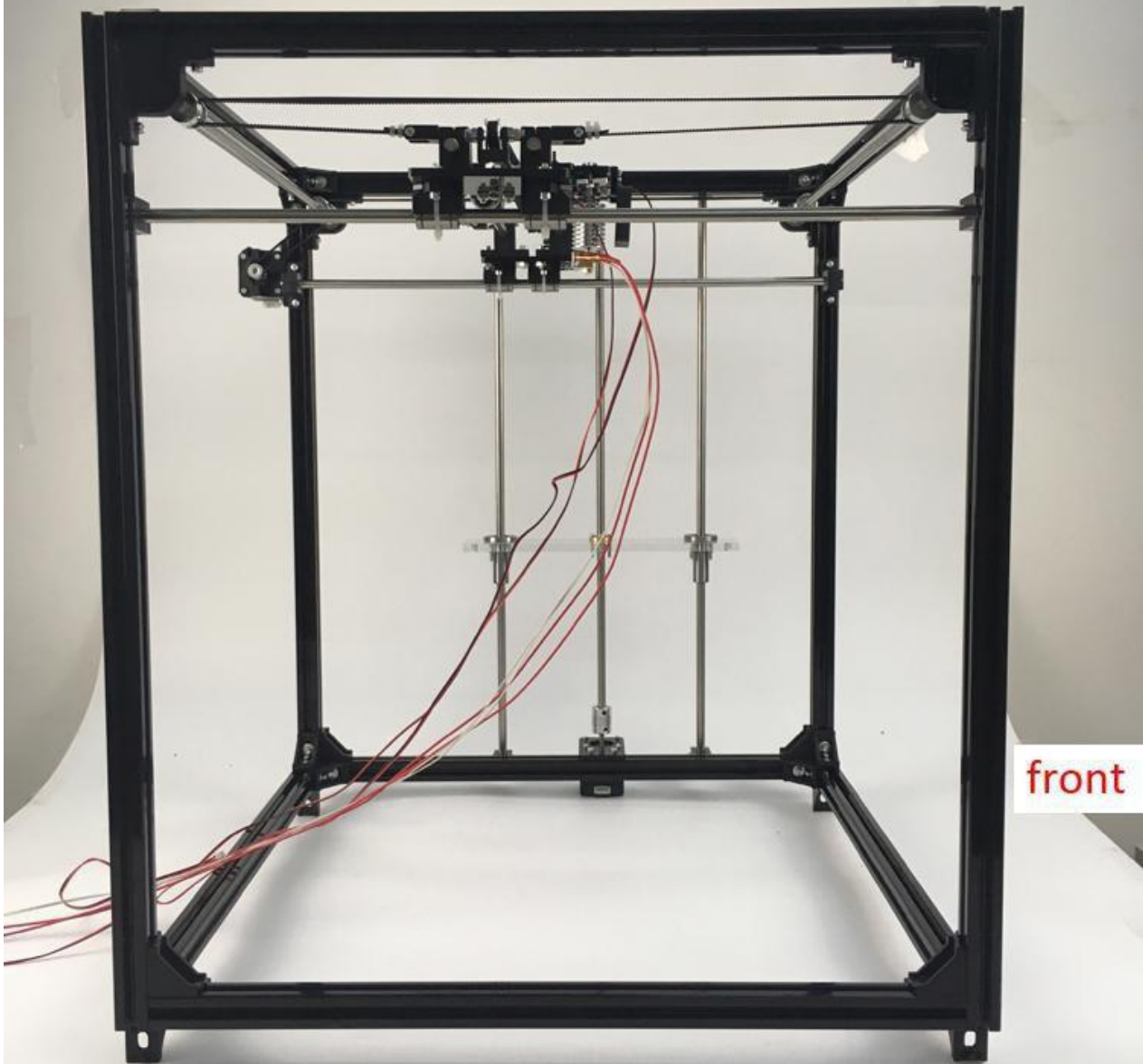

front

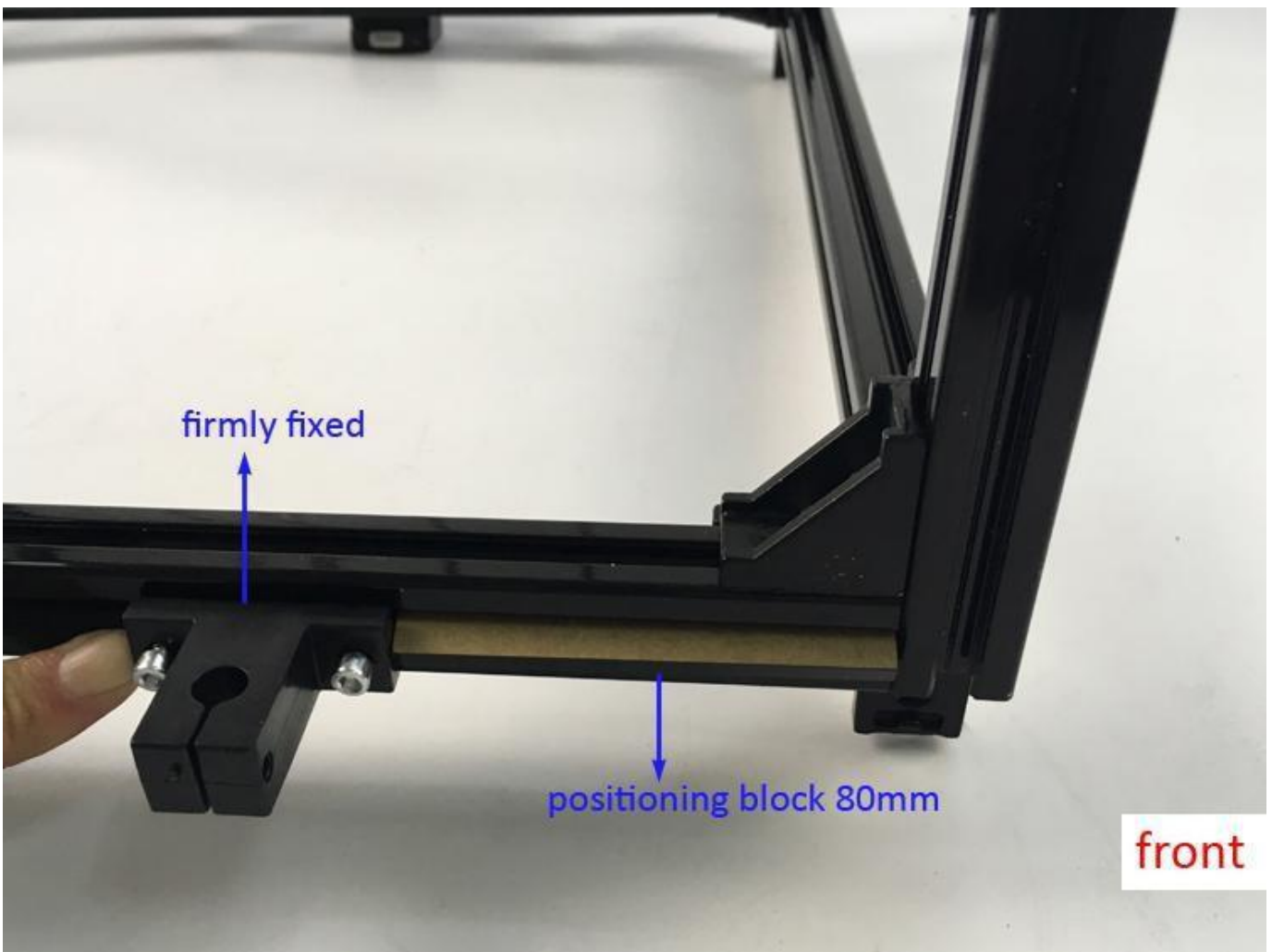

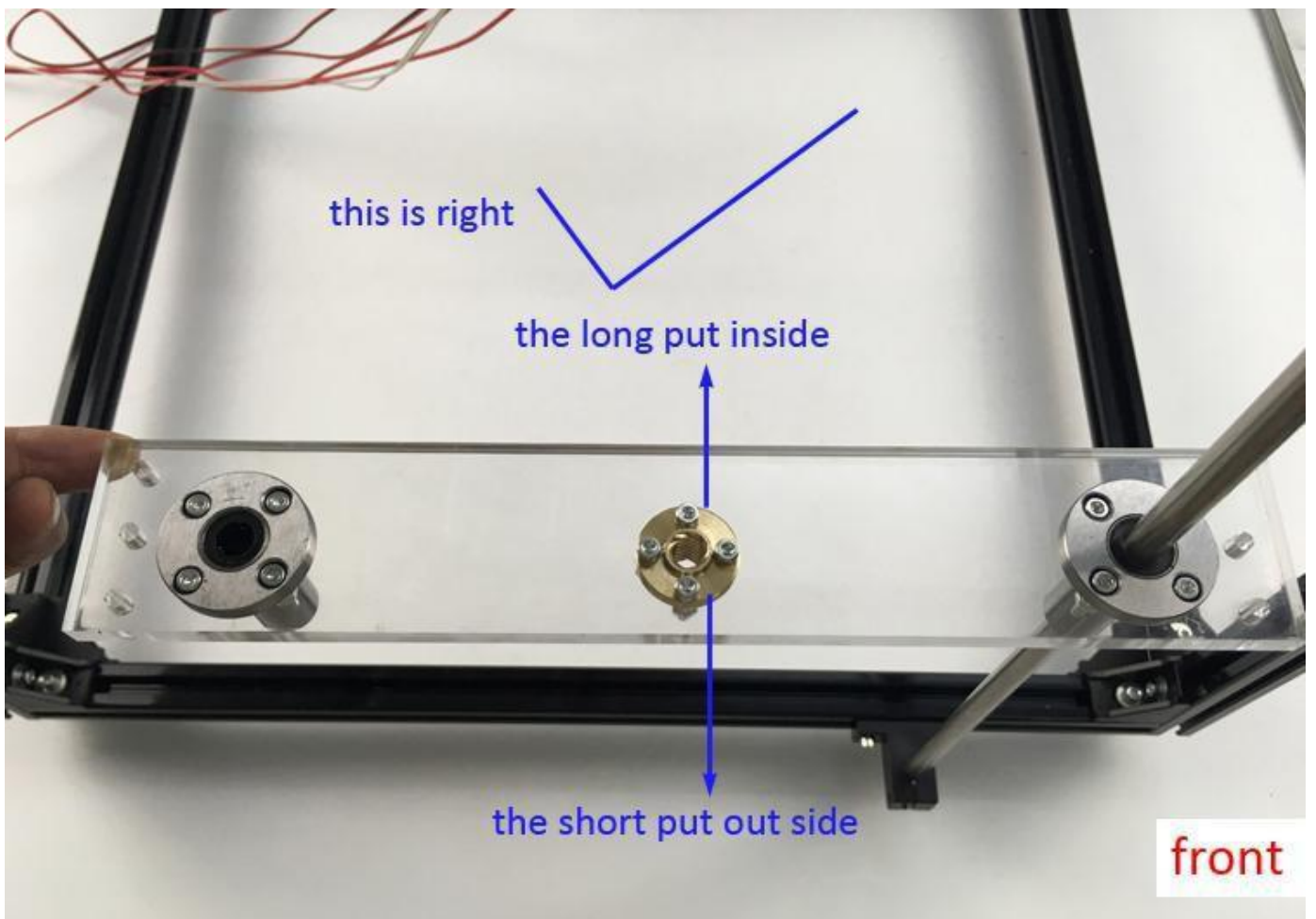
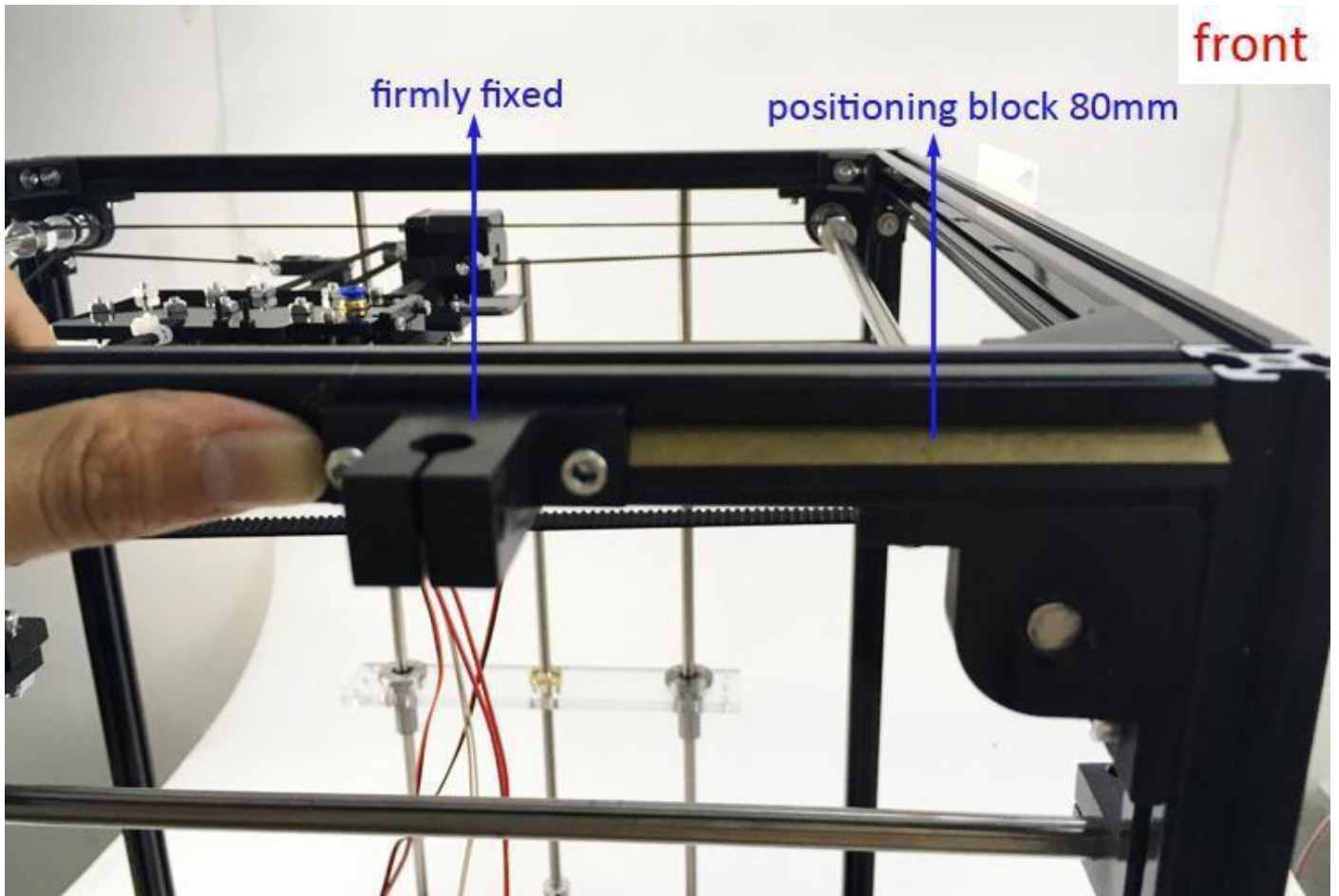

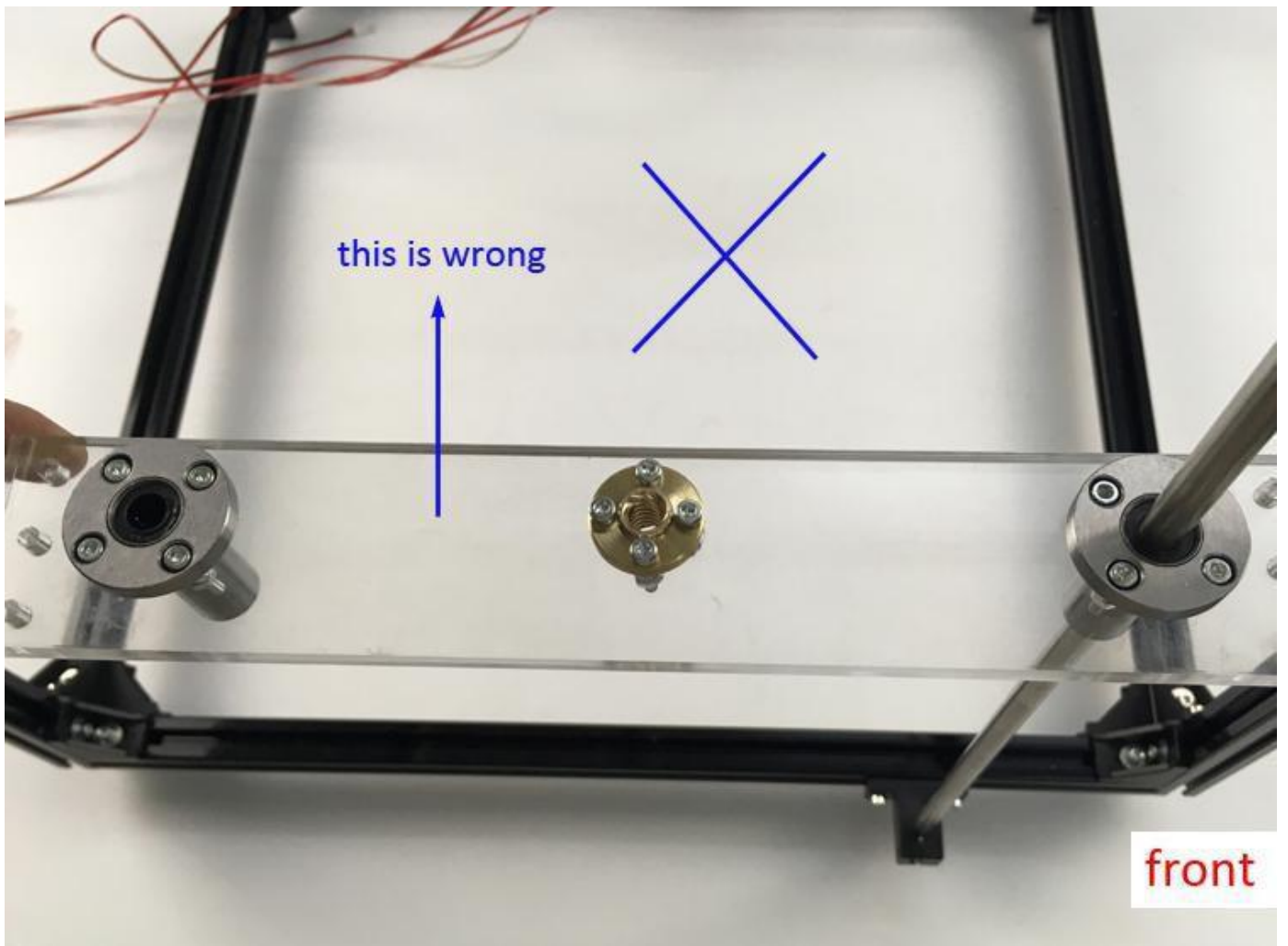



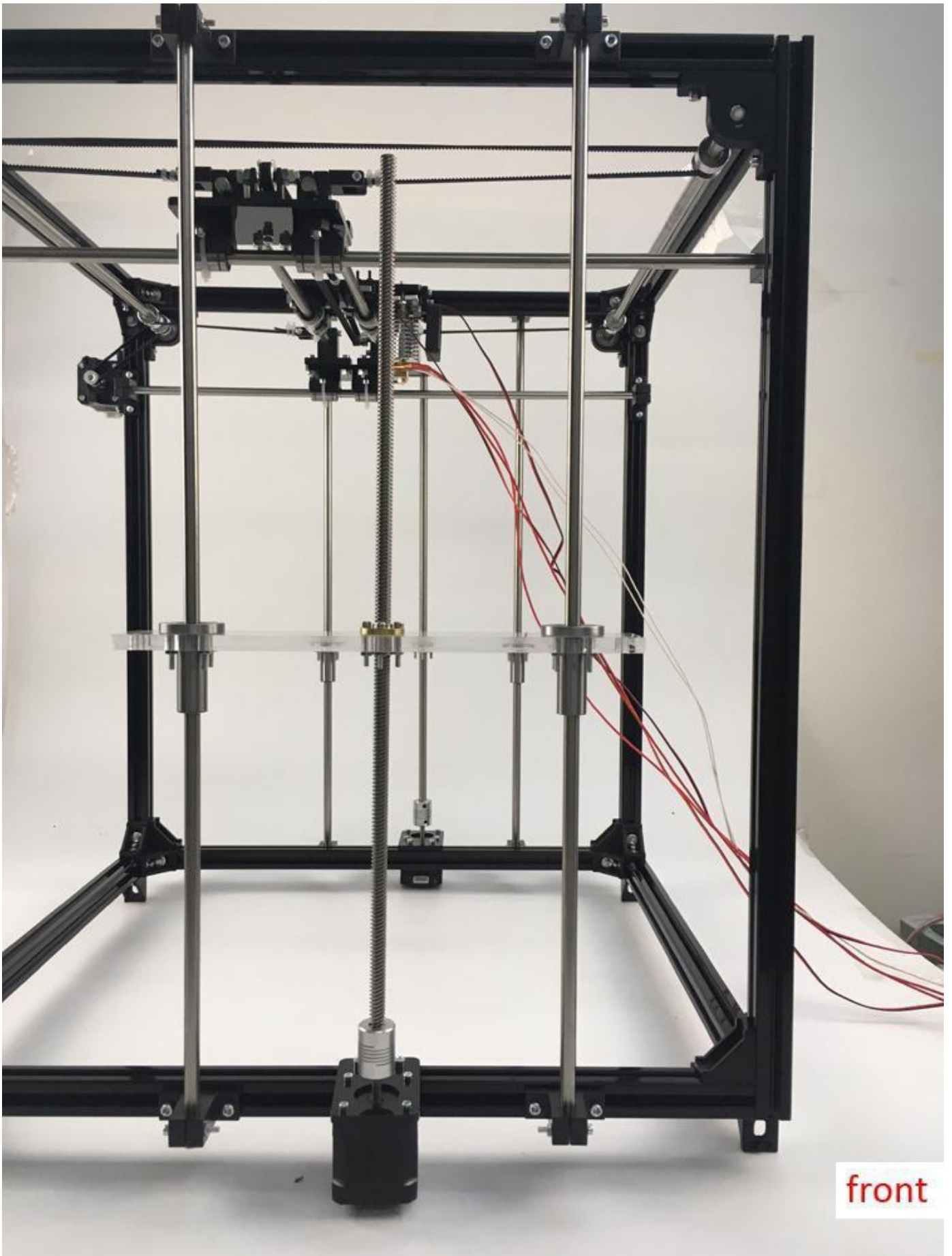

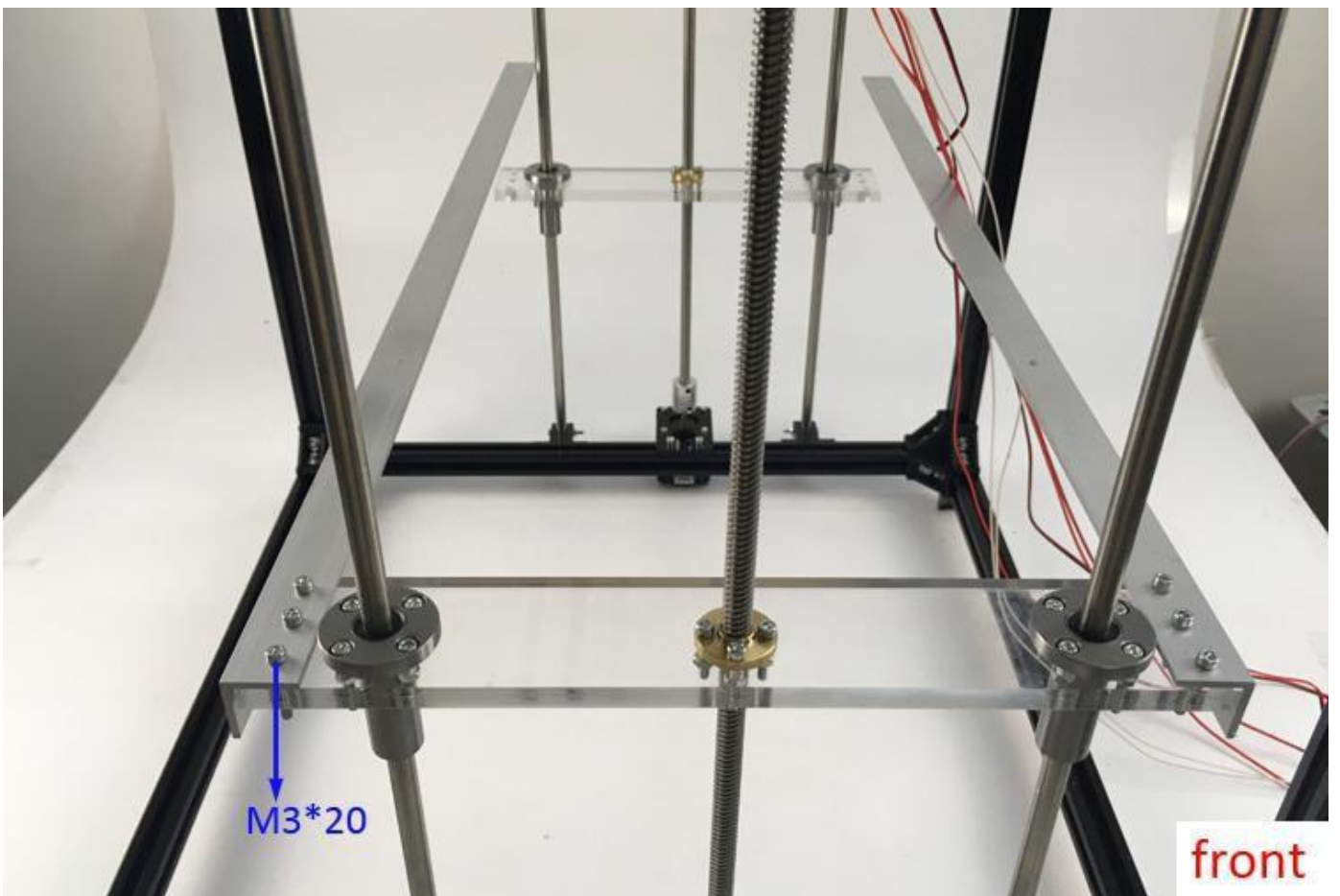

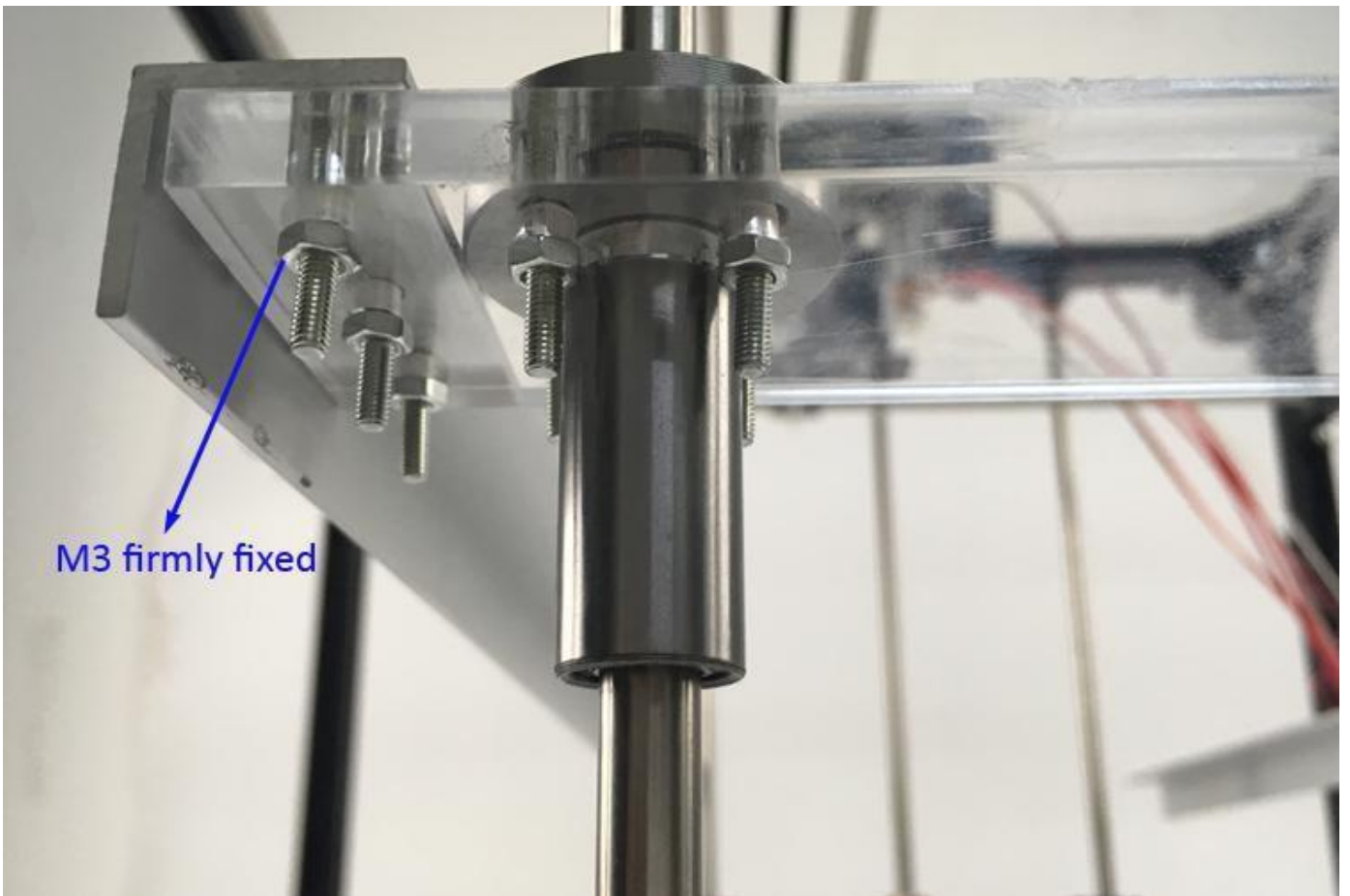
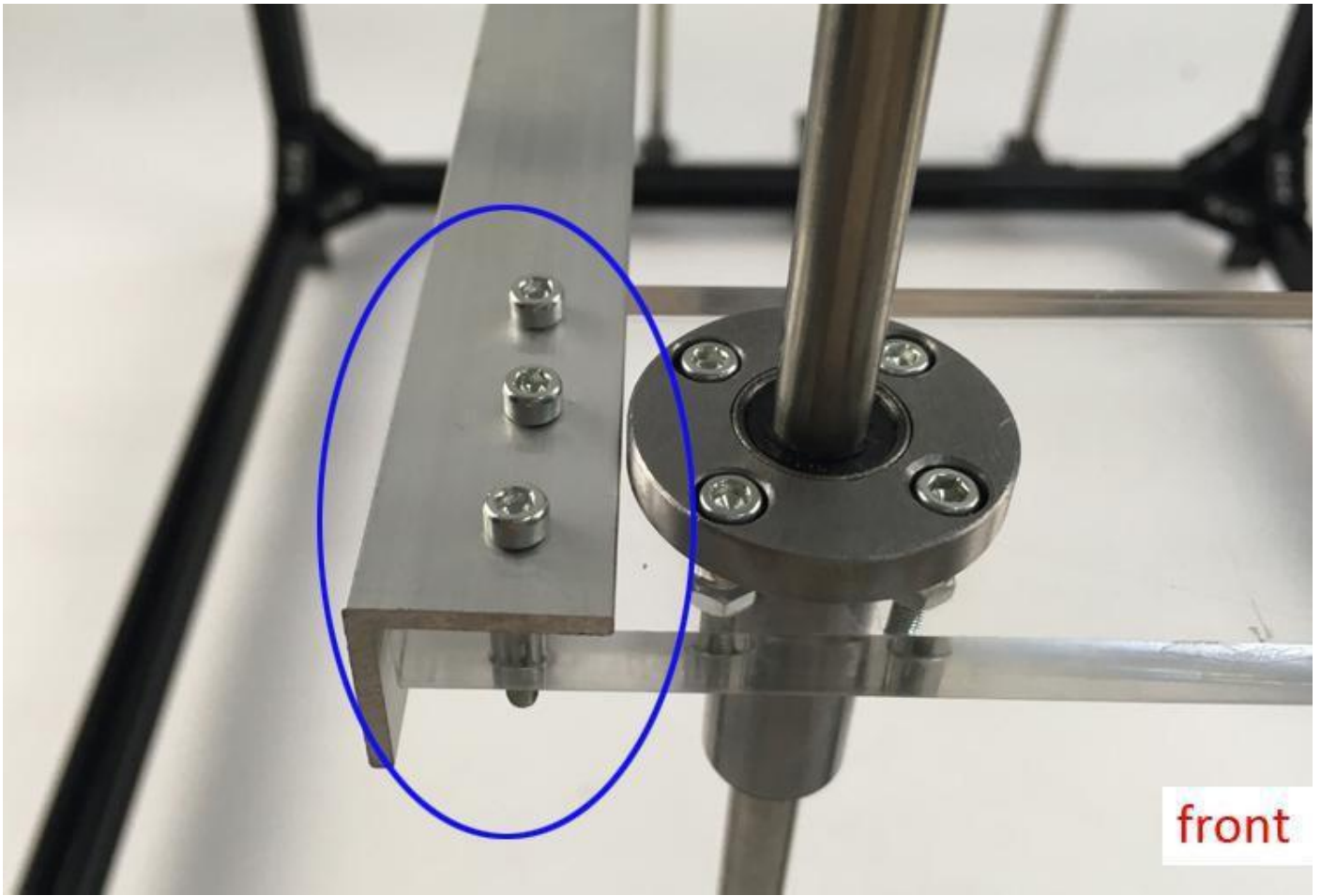

rotate 180°, assembly another  
rotate the screw rod, up the  
support

front

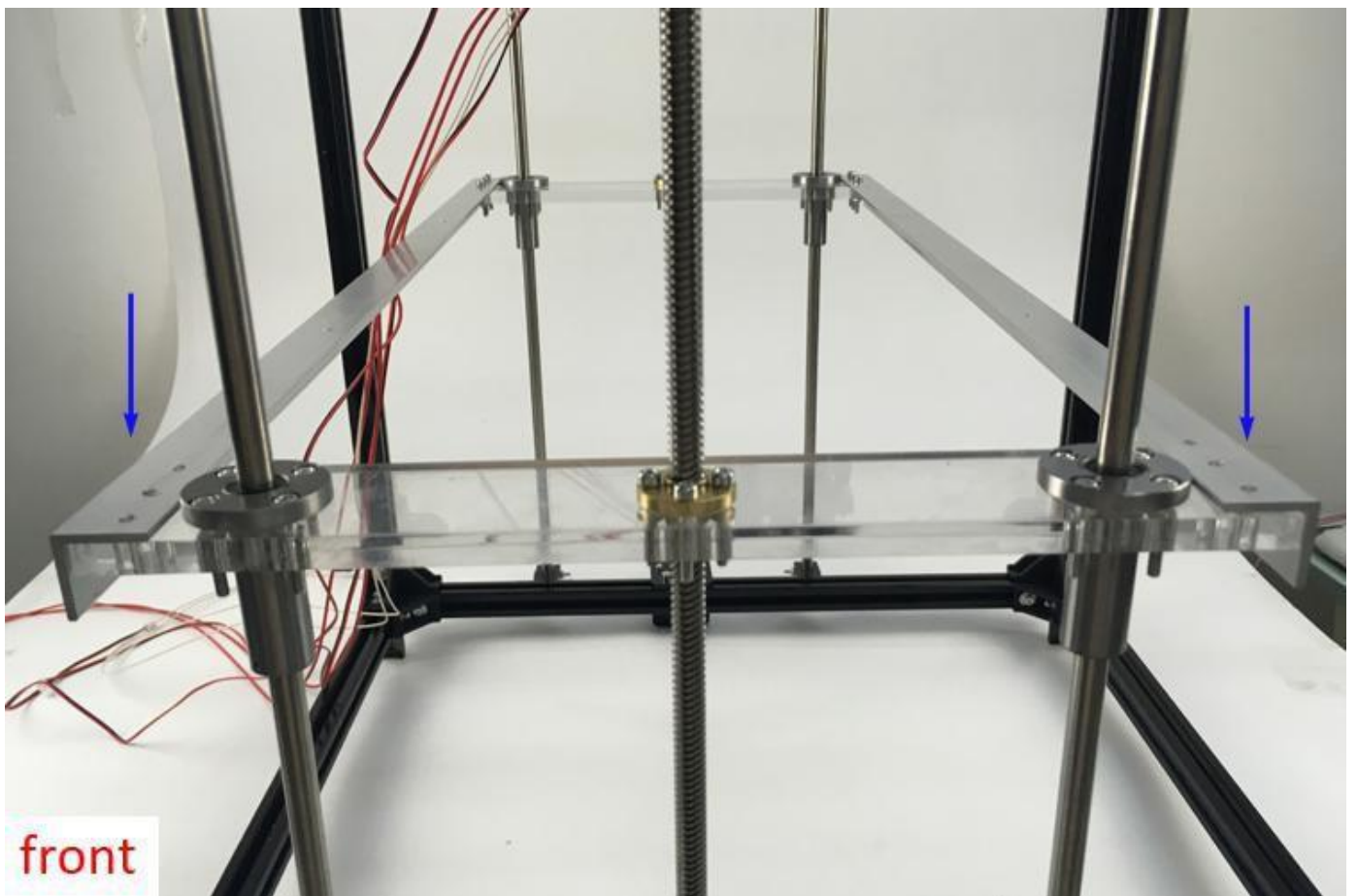

front

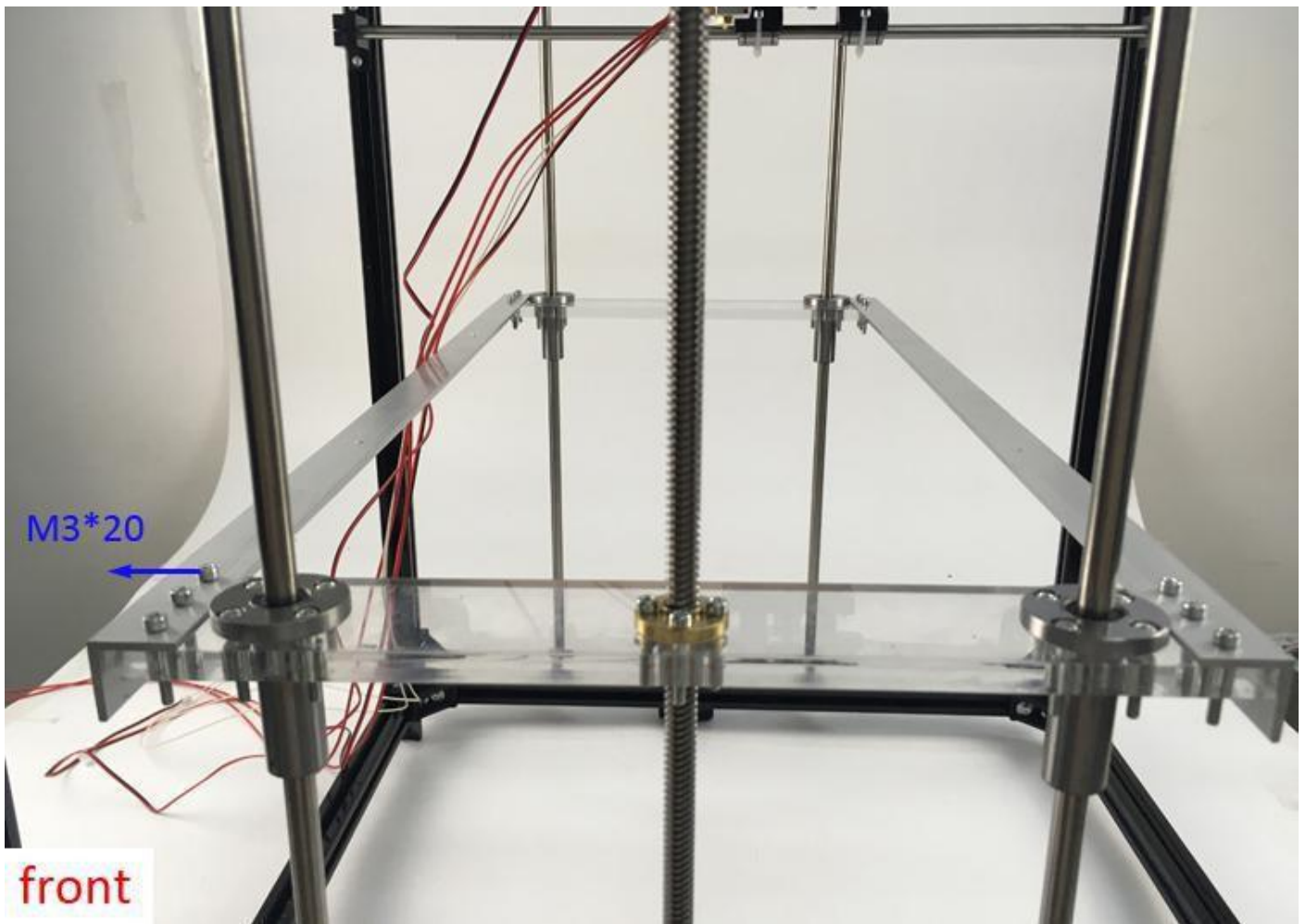

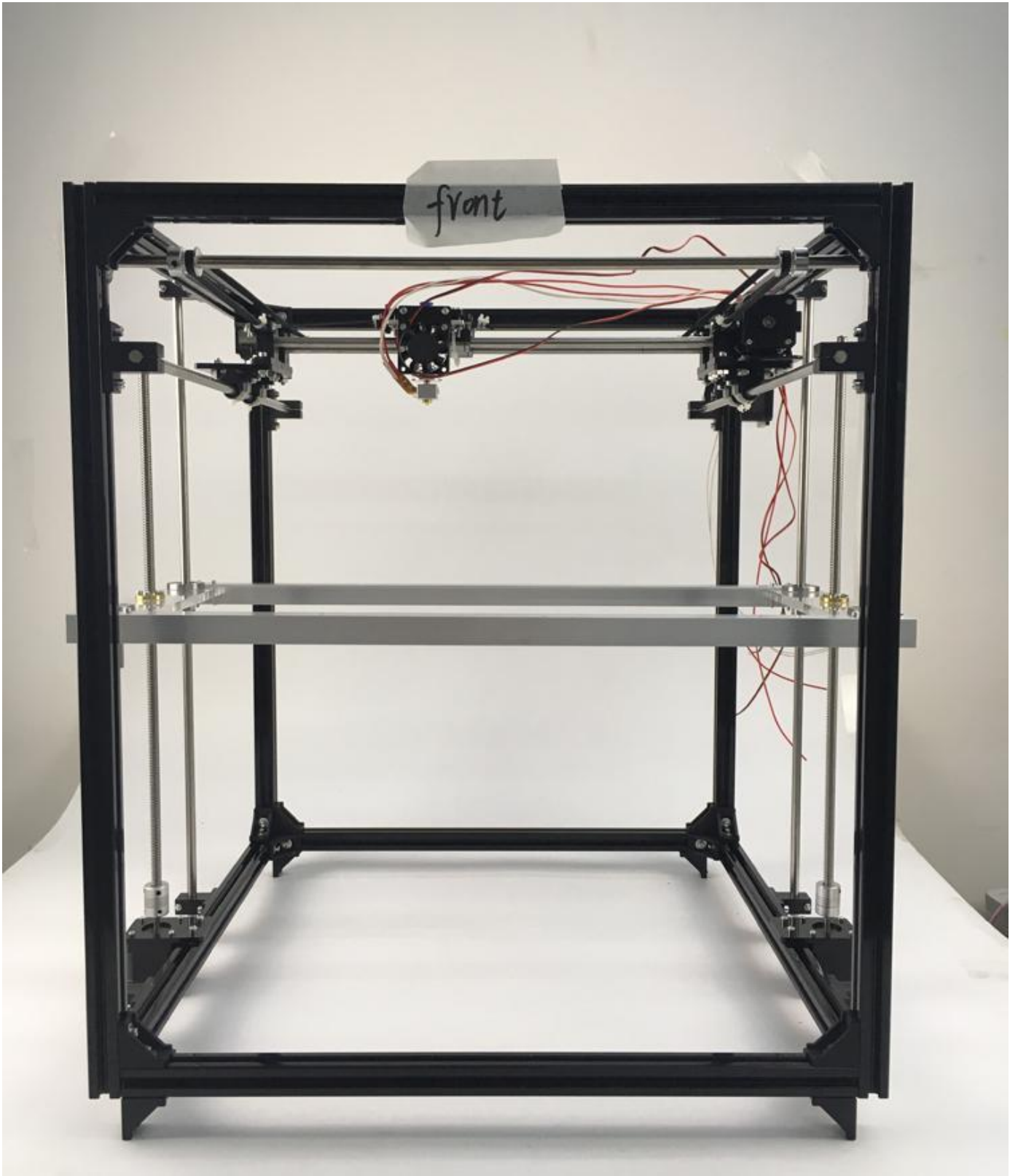

front

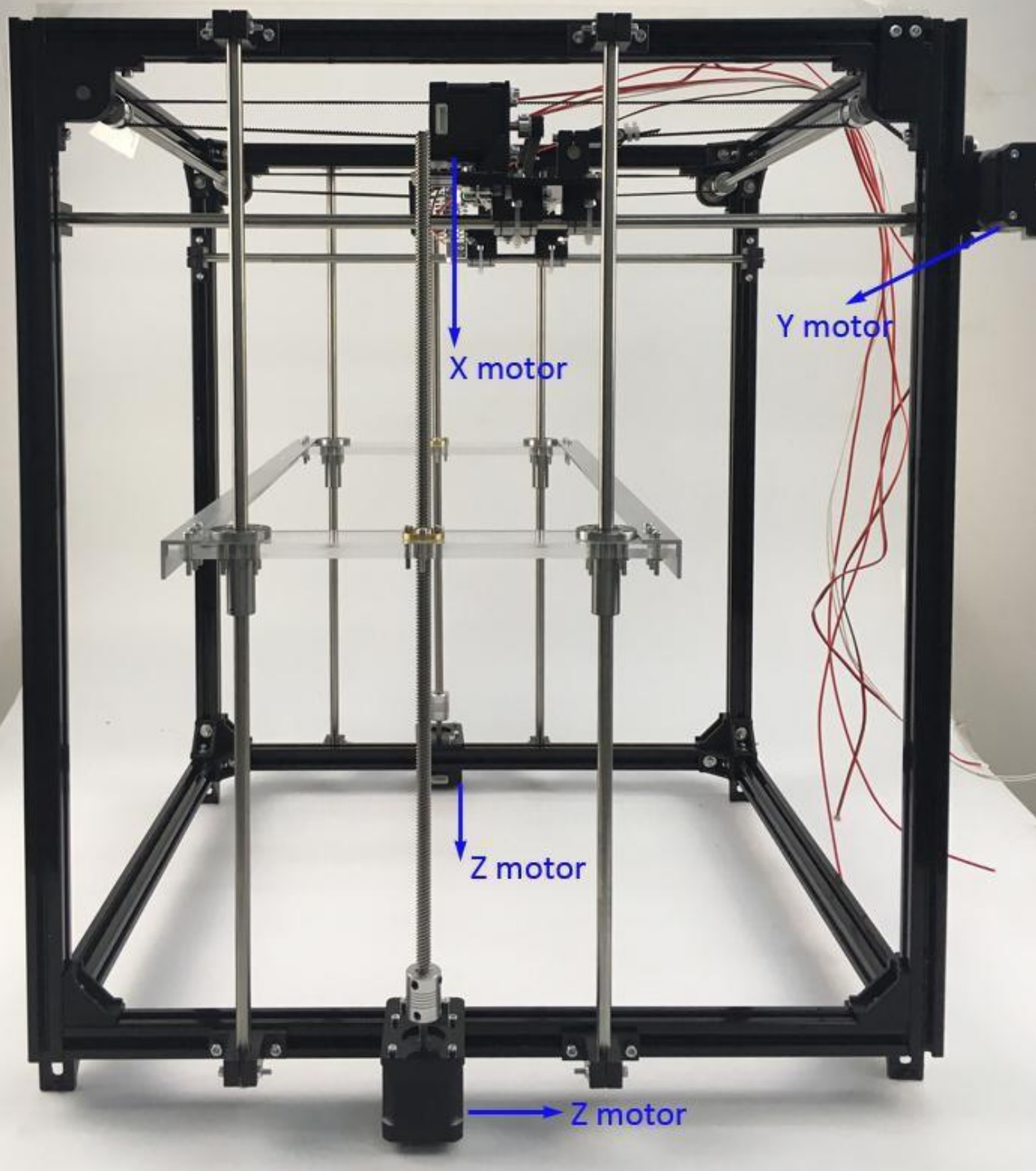

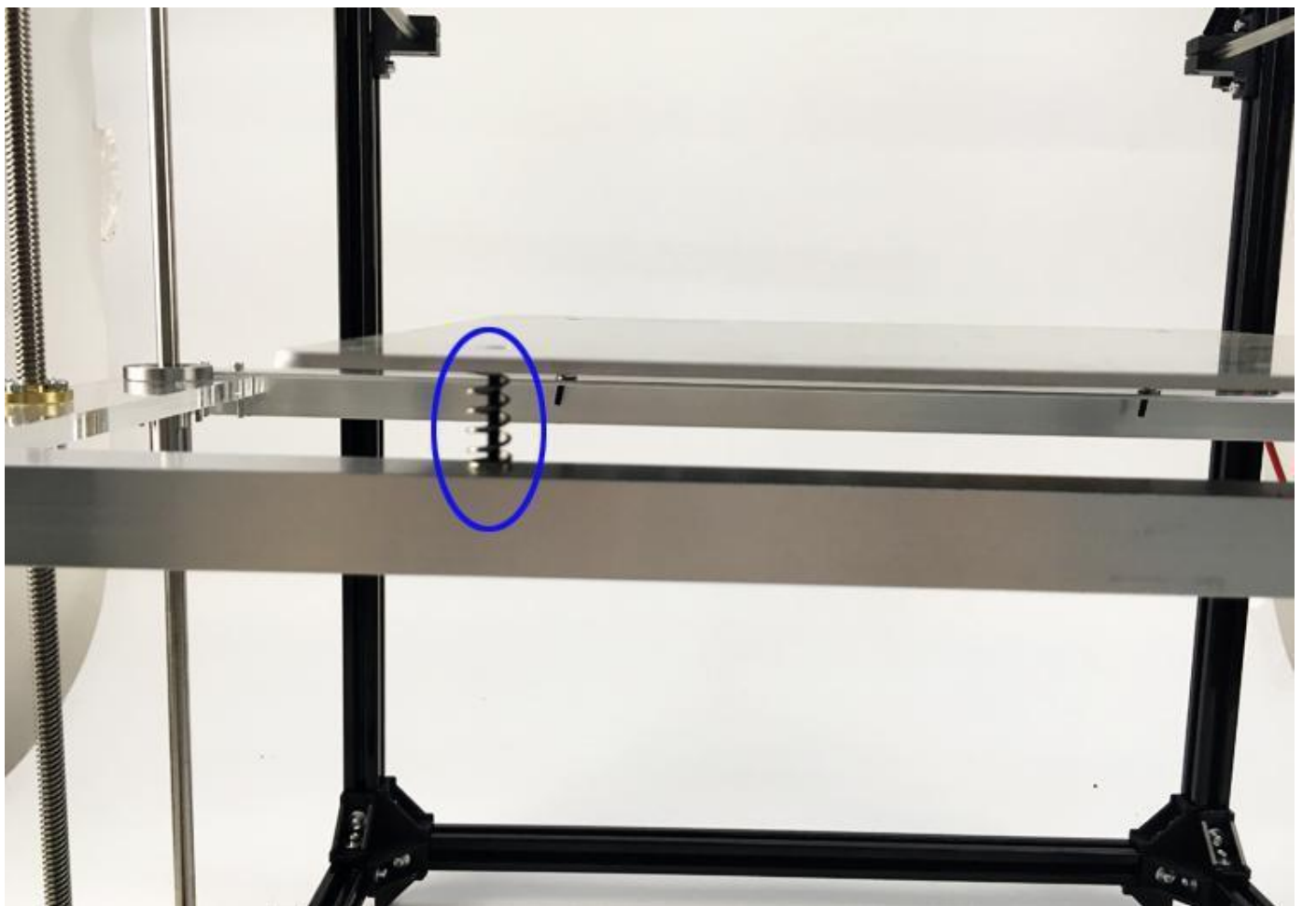
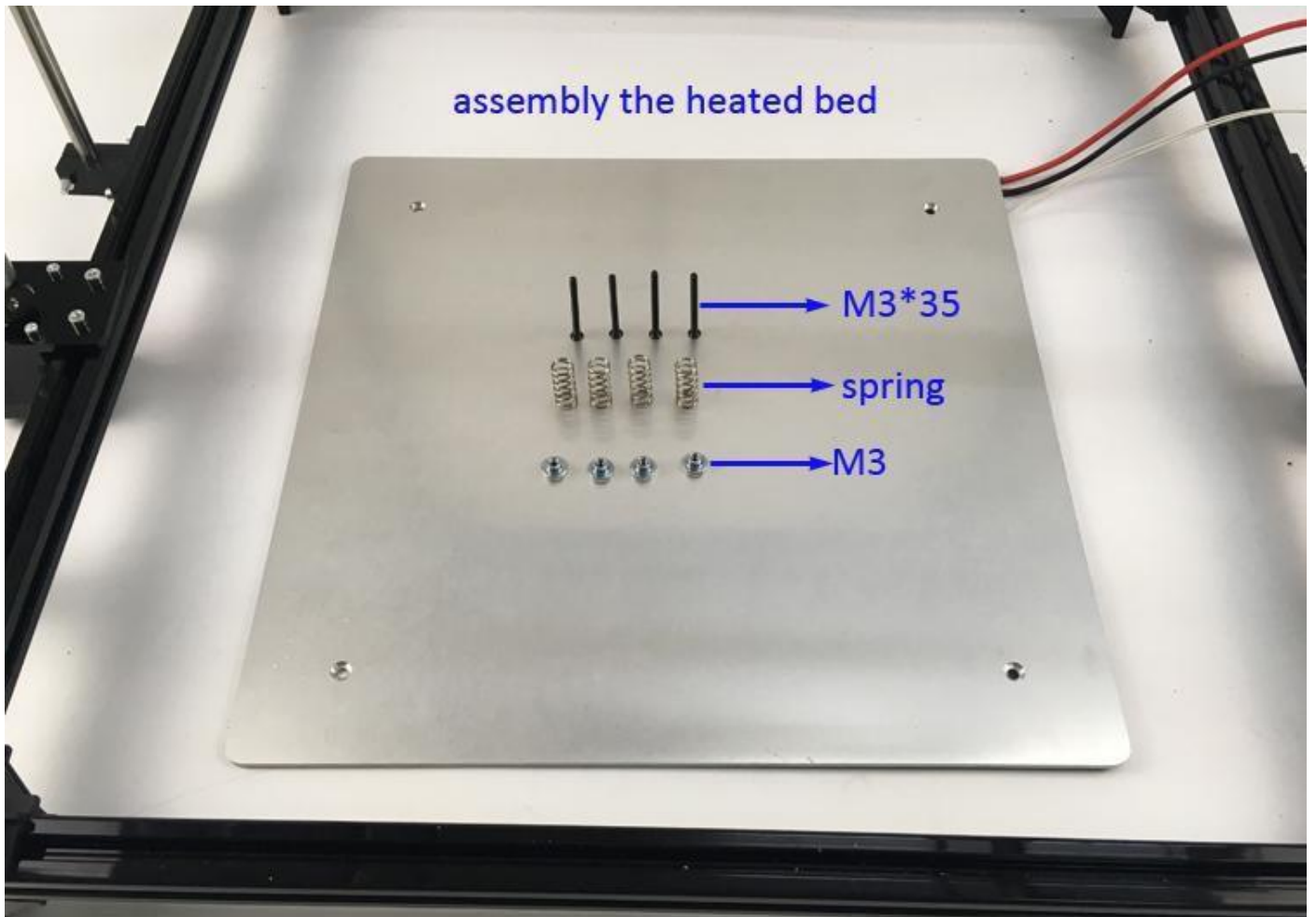



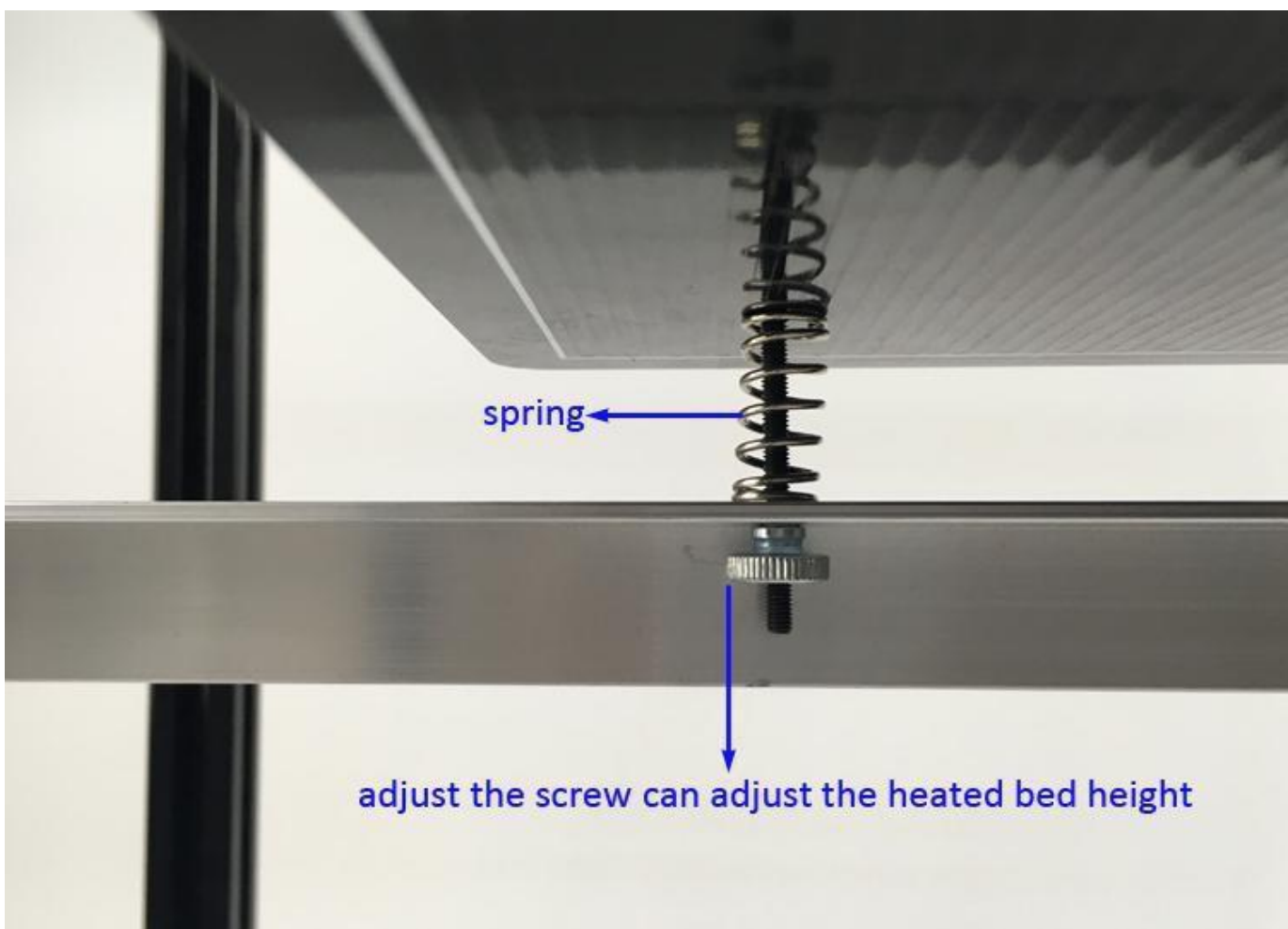
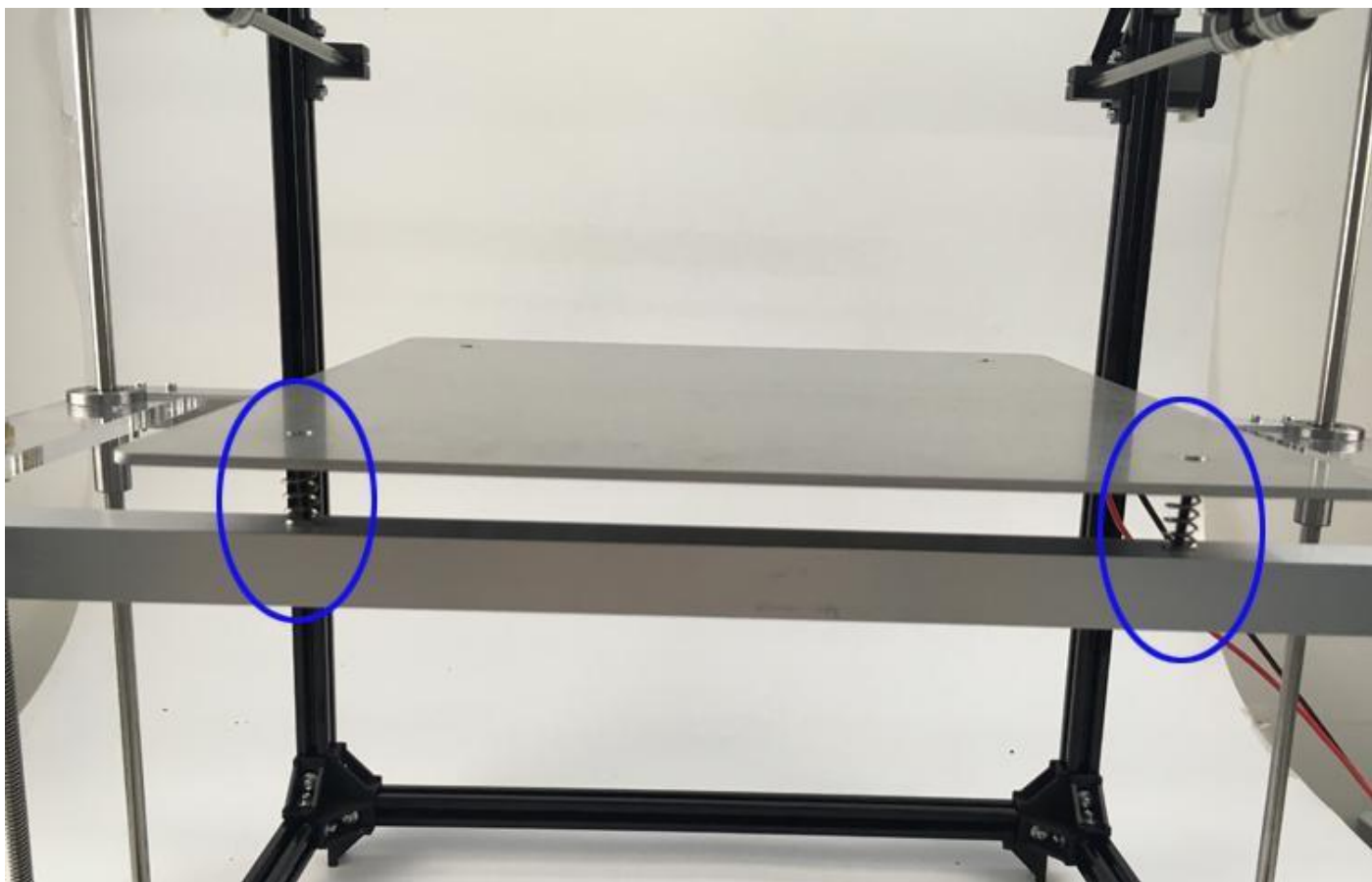

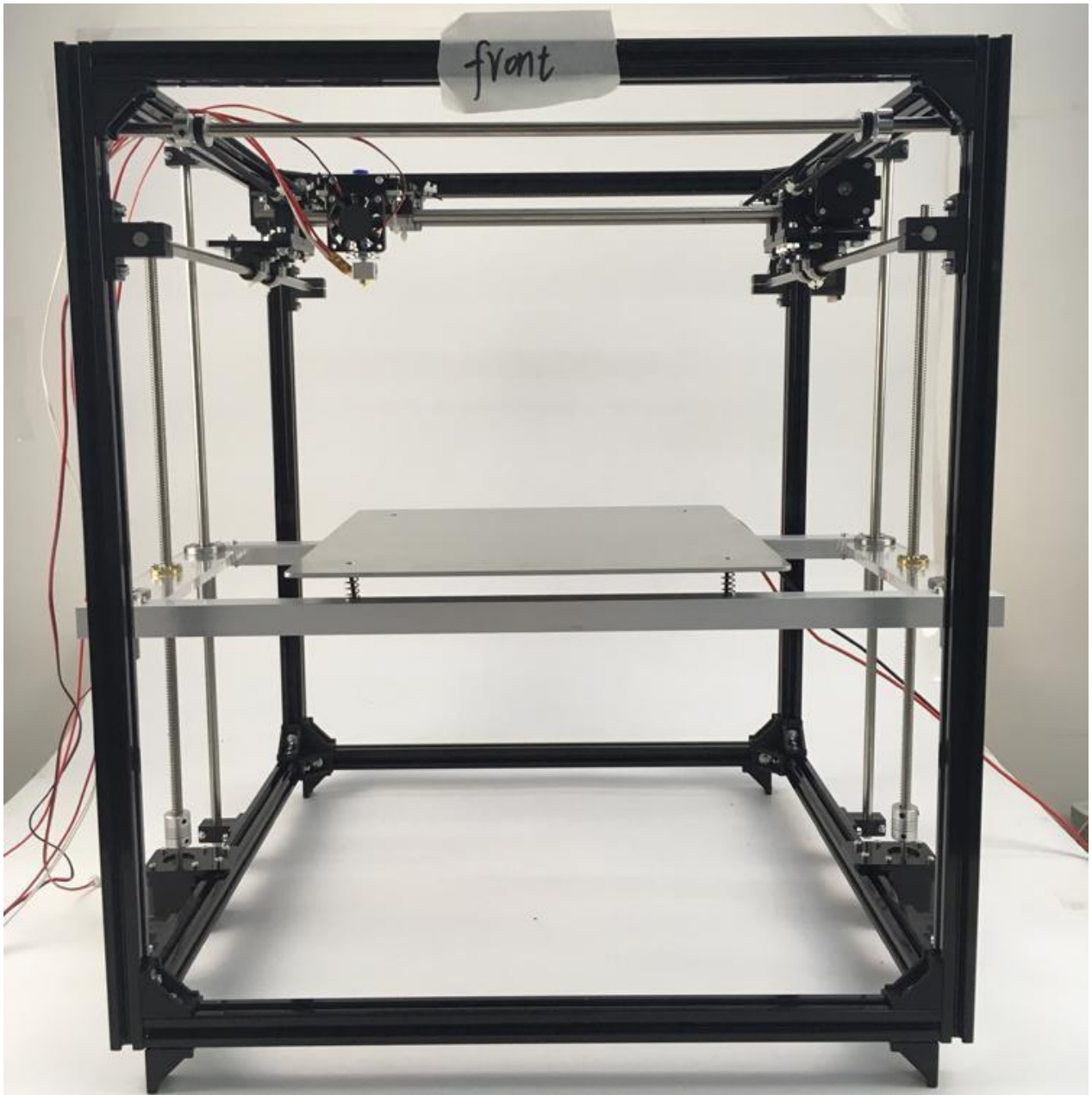

## 4 Assembly Y switch and Z switch

If you have installed an auto leveling sensor, you can not install the Z-axis limit switch, The Z-axis limit switch is only suitable for manual leveling

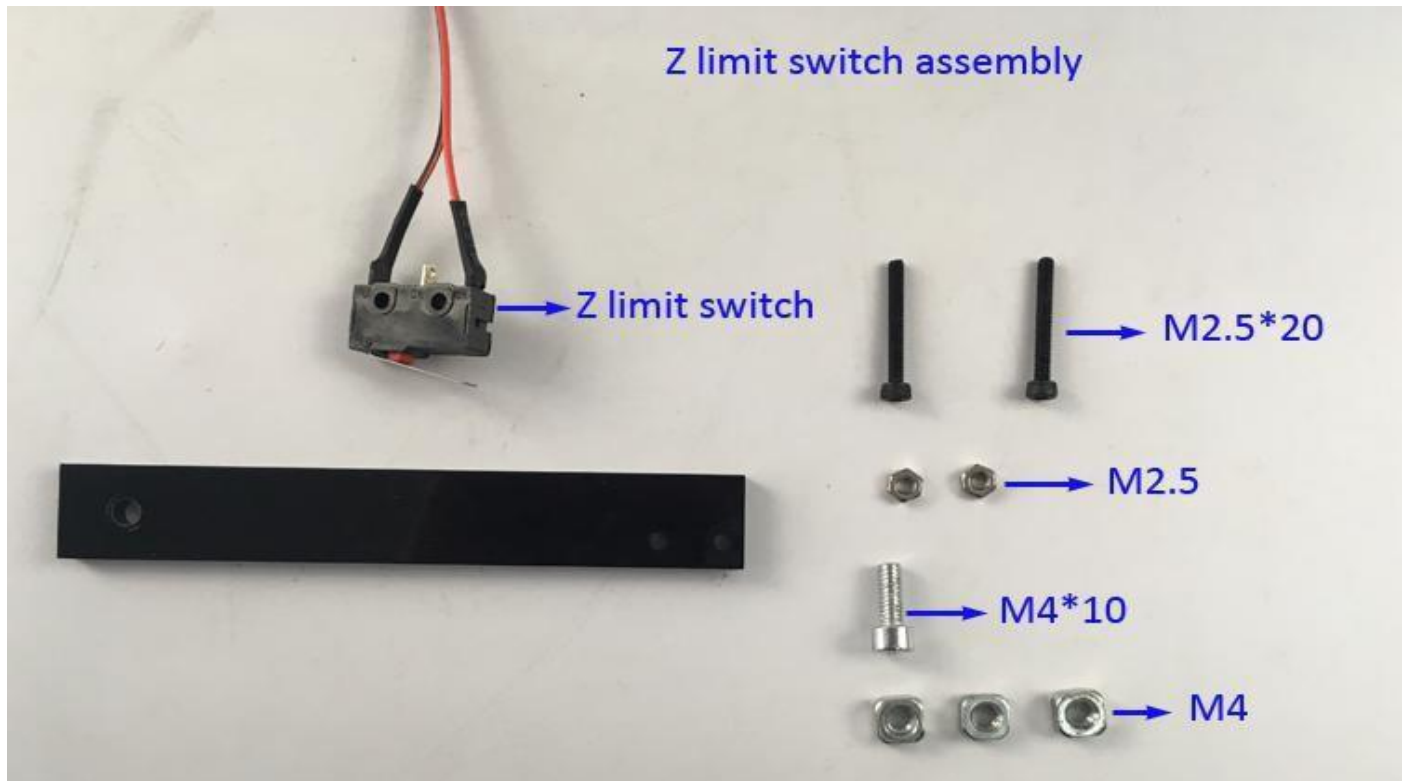

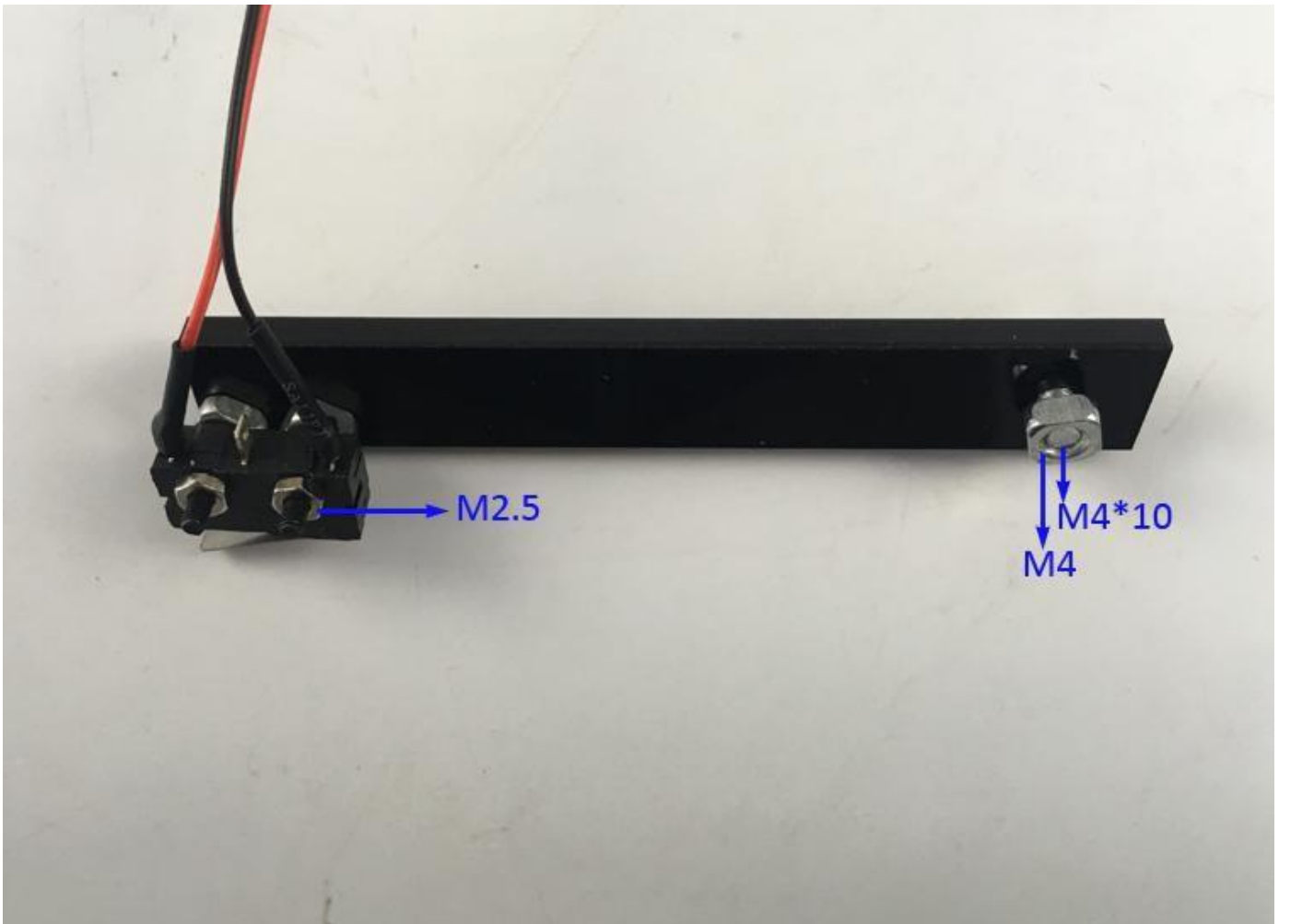
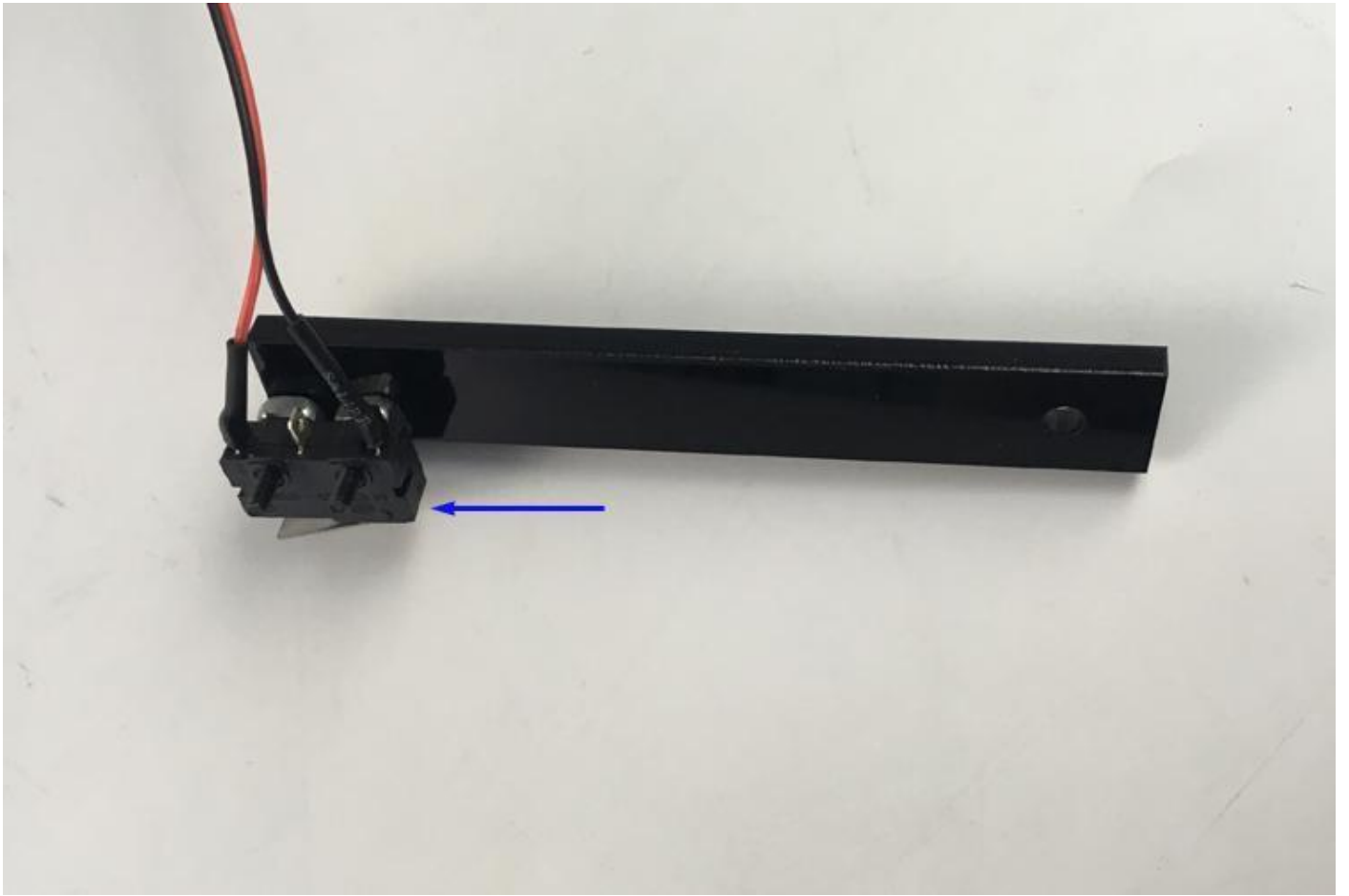

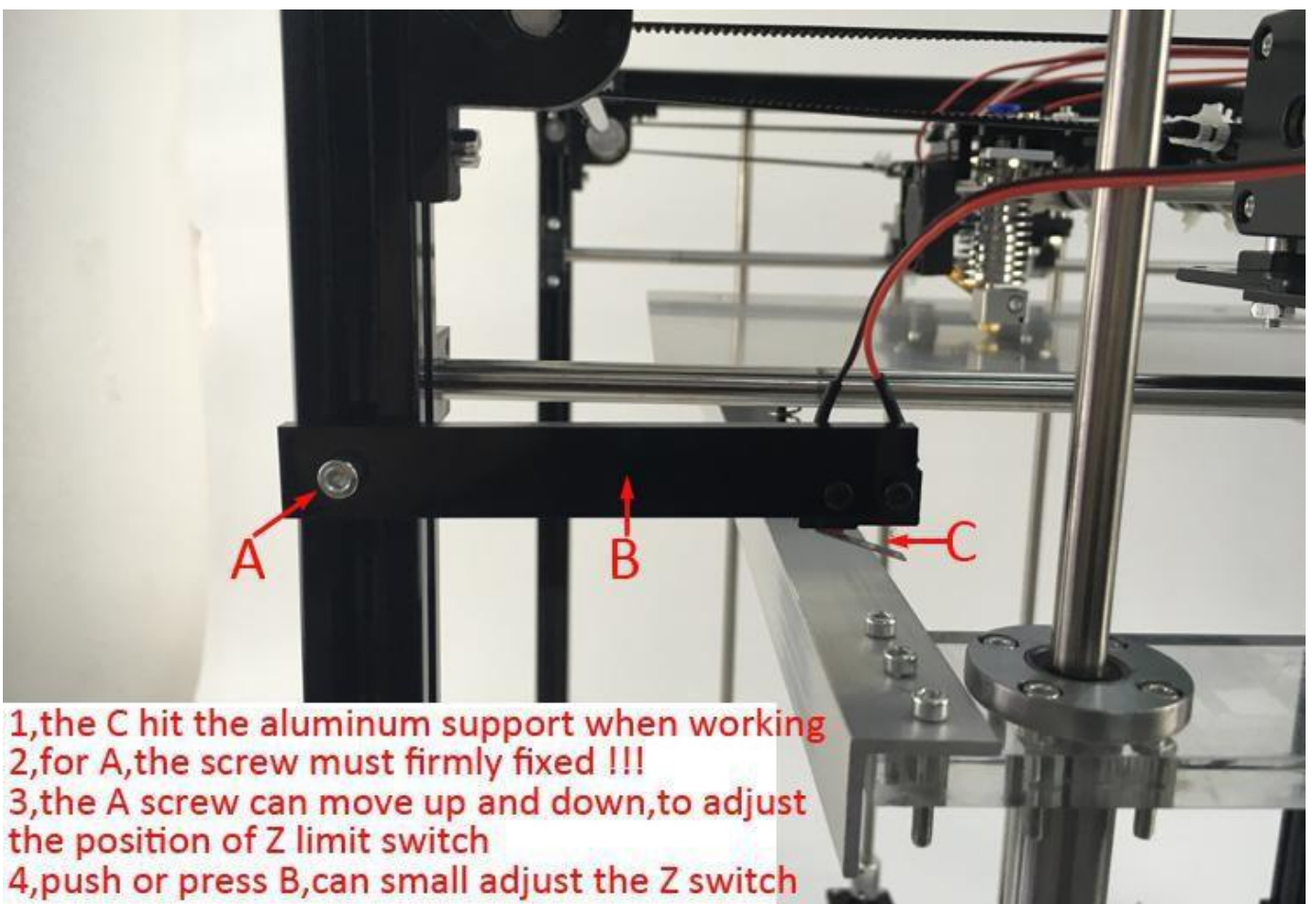
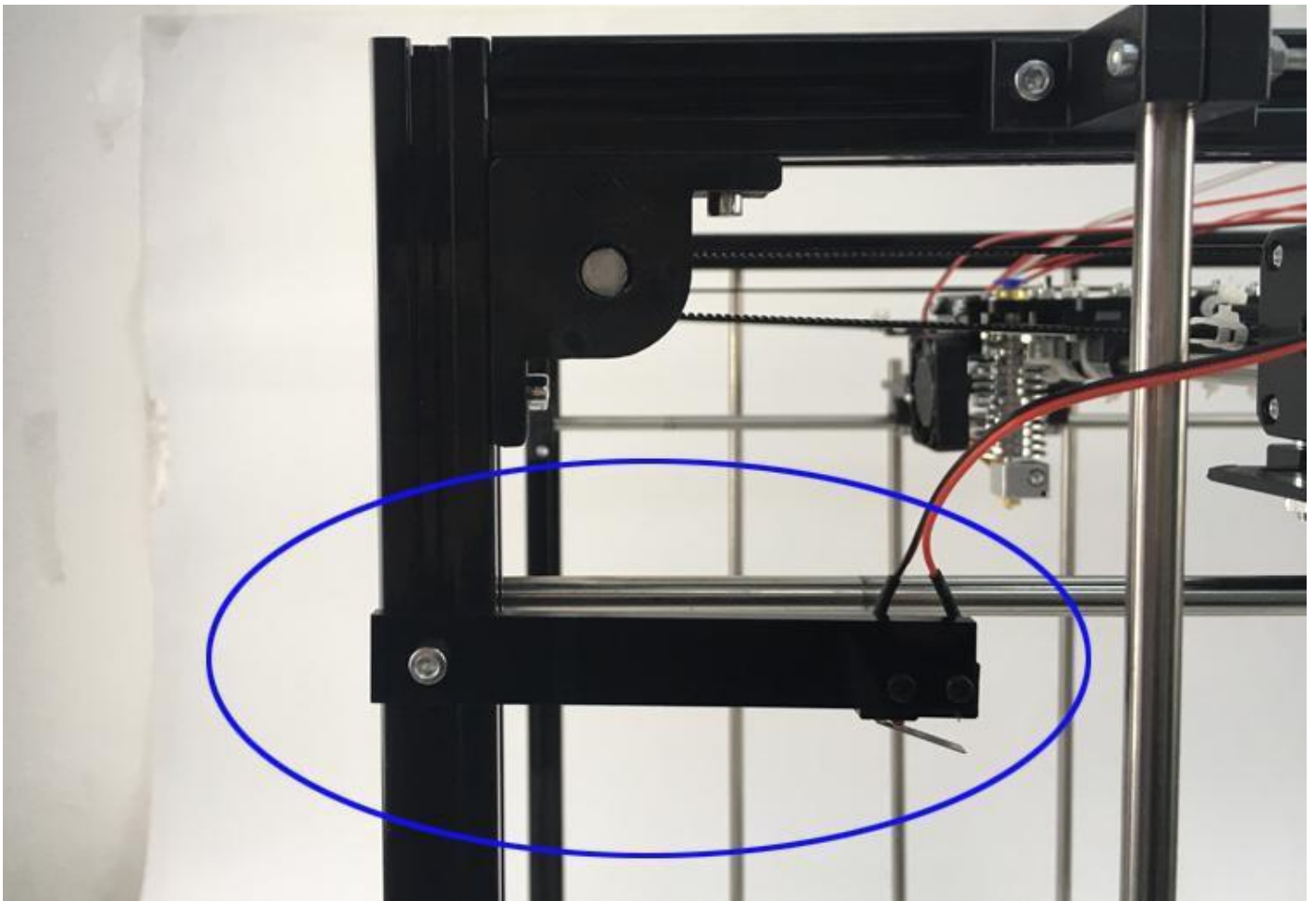

- 1, the C hit the aluminum support when working
- 2, for A, the screw must firmly fixed !!!
- 3, the A screw can move up and down, to adjust the position of Z limit switch
- 4, push or press B, can small adjust the Z switch

### Y limit switch assembly

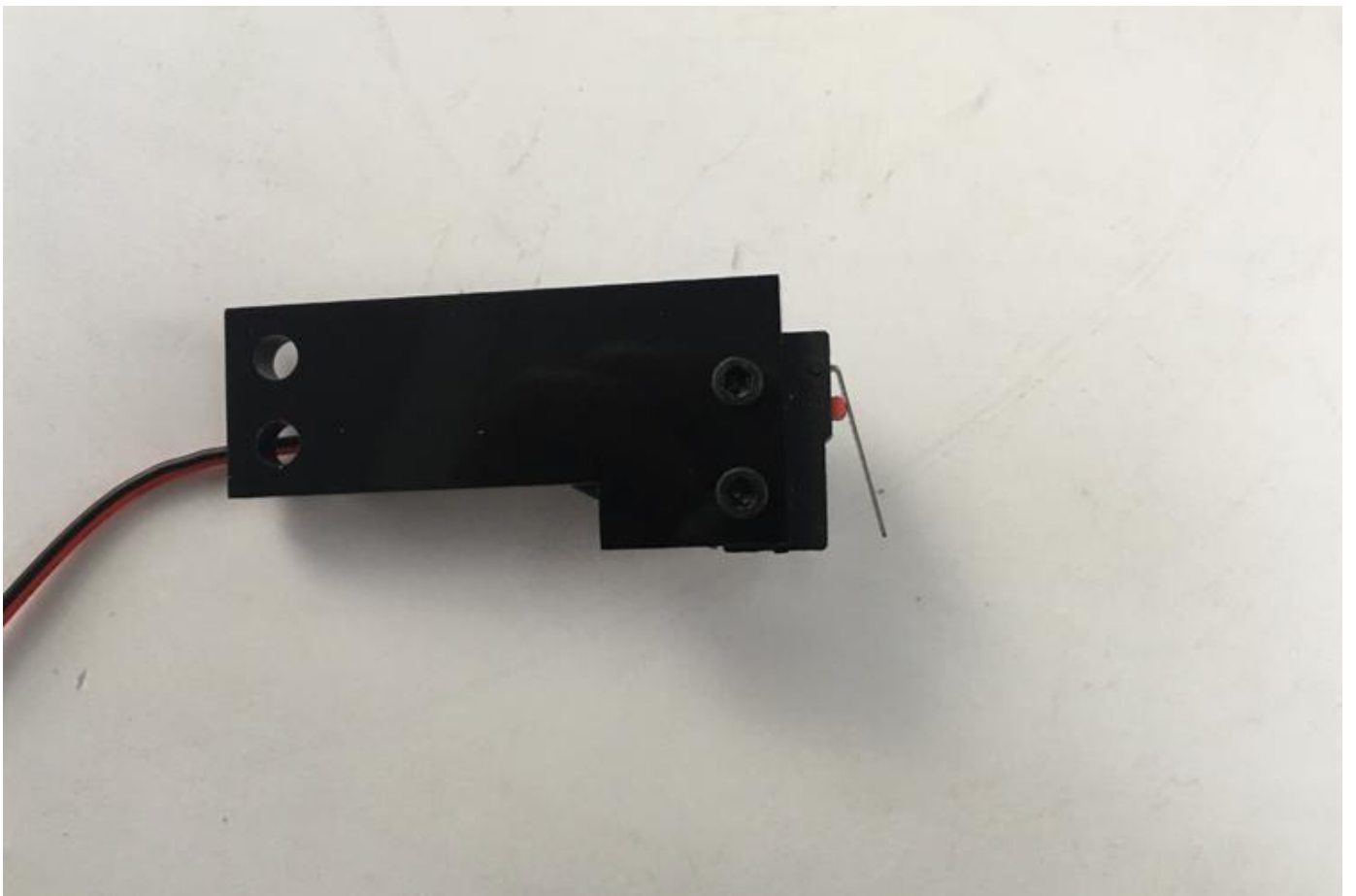
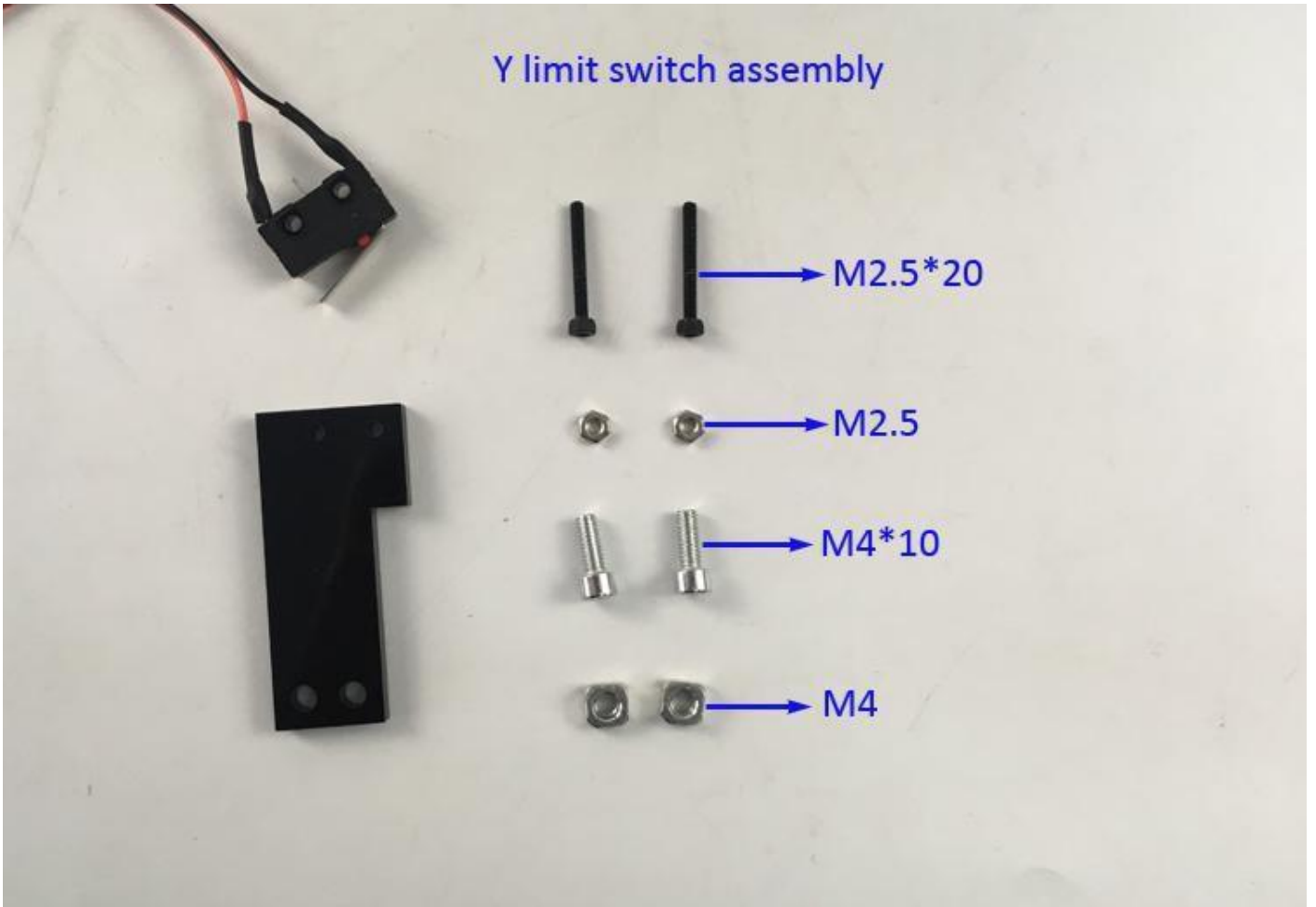

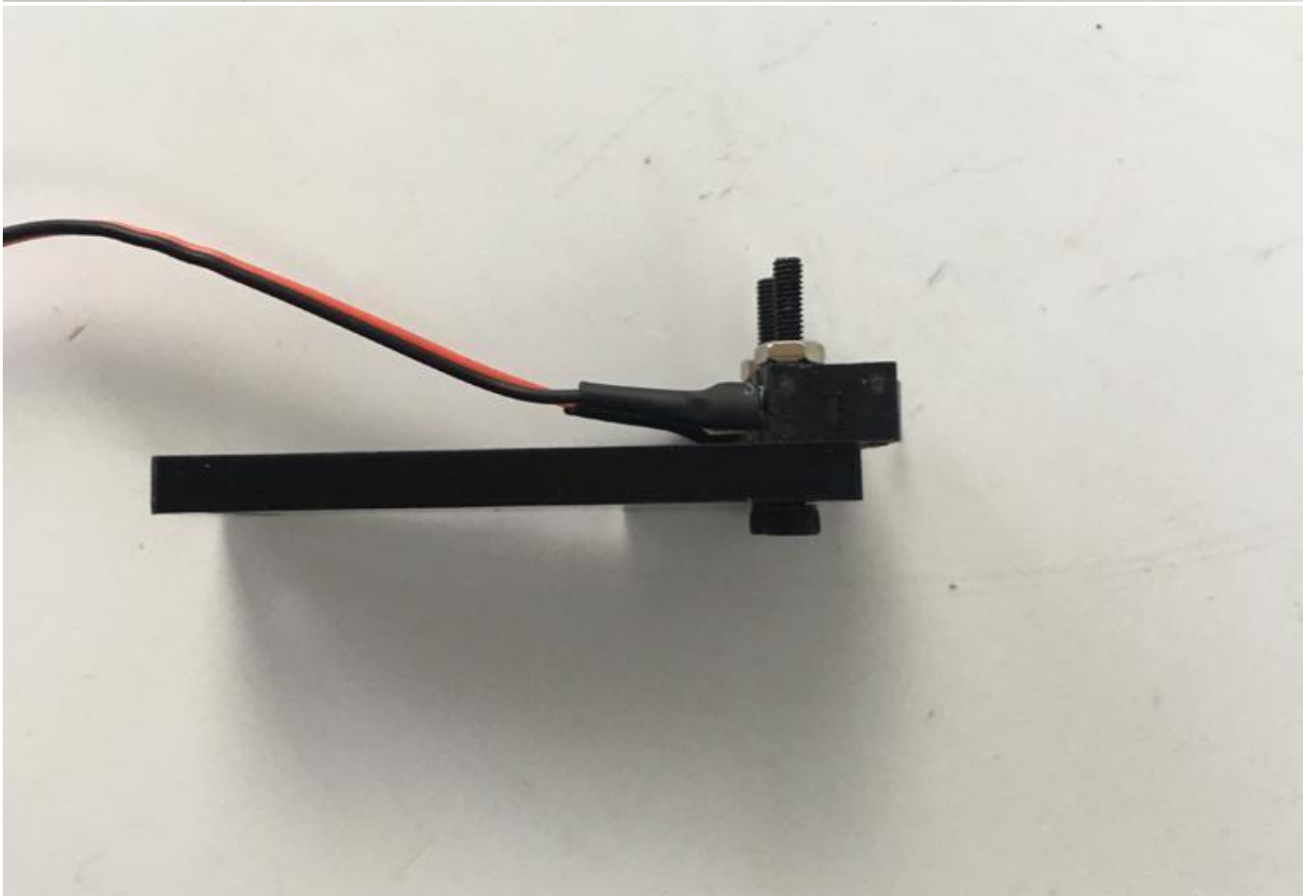
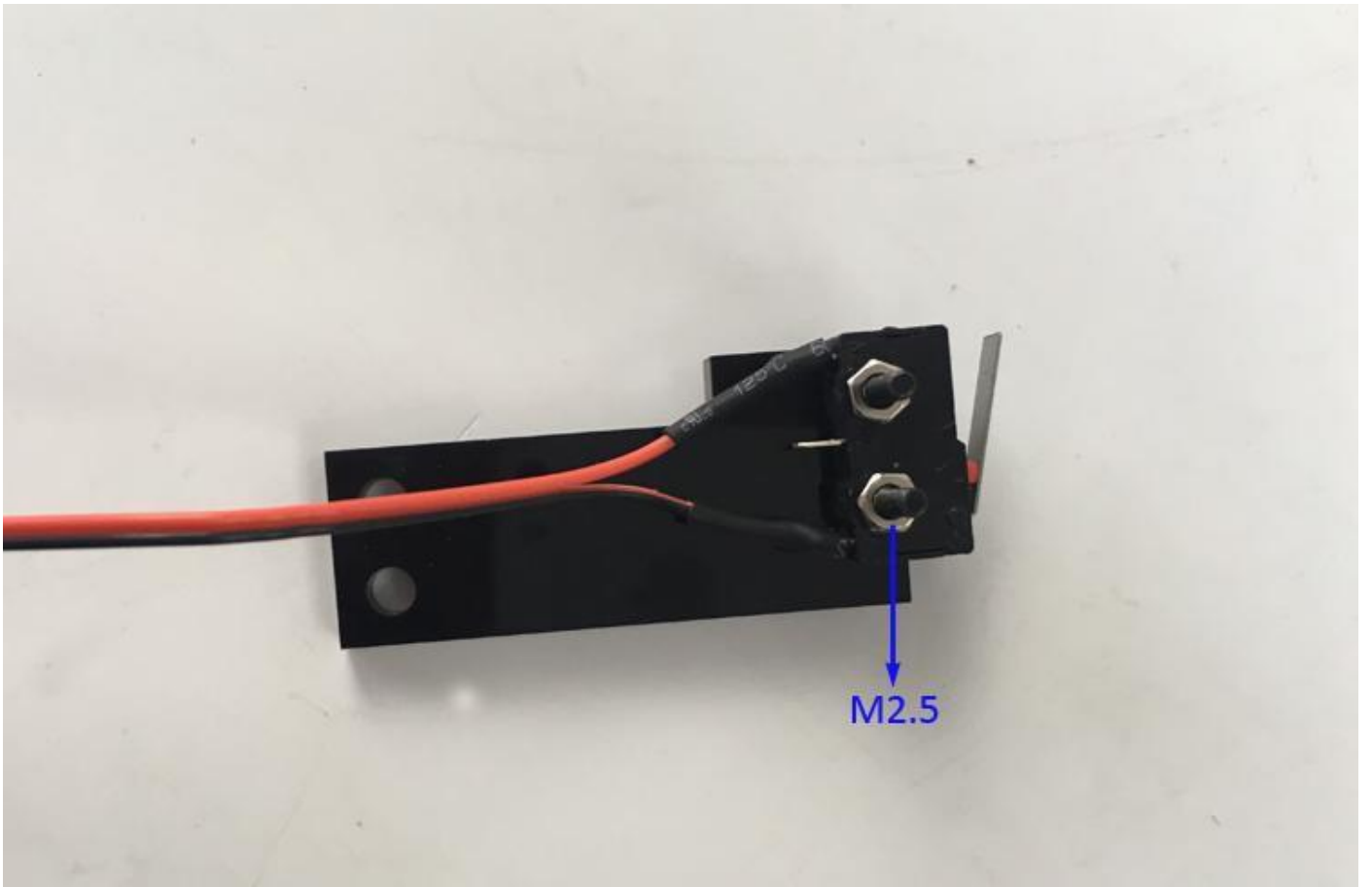

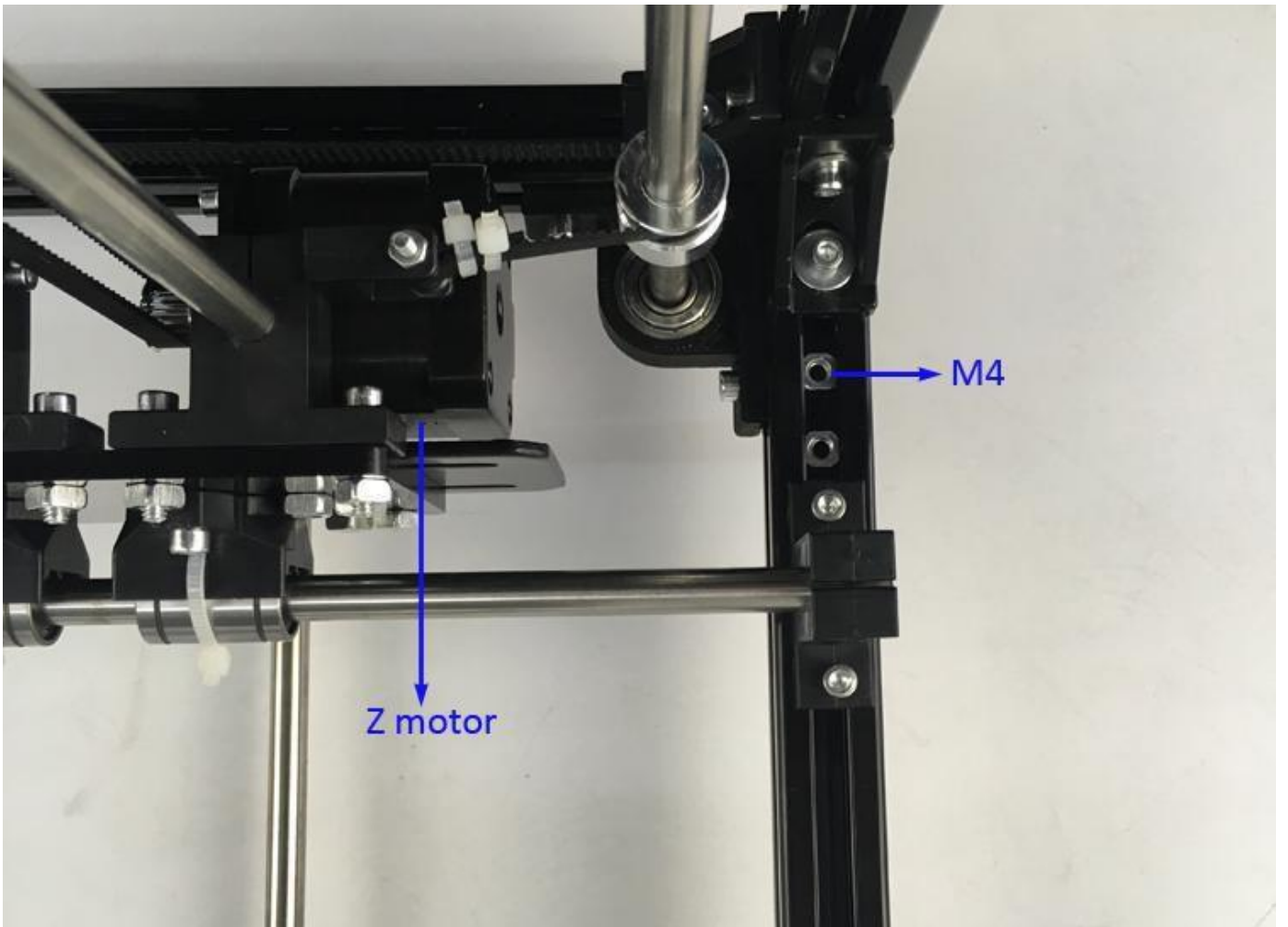
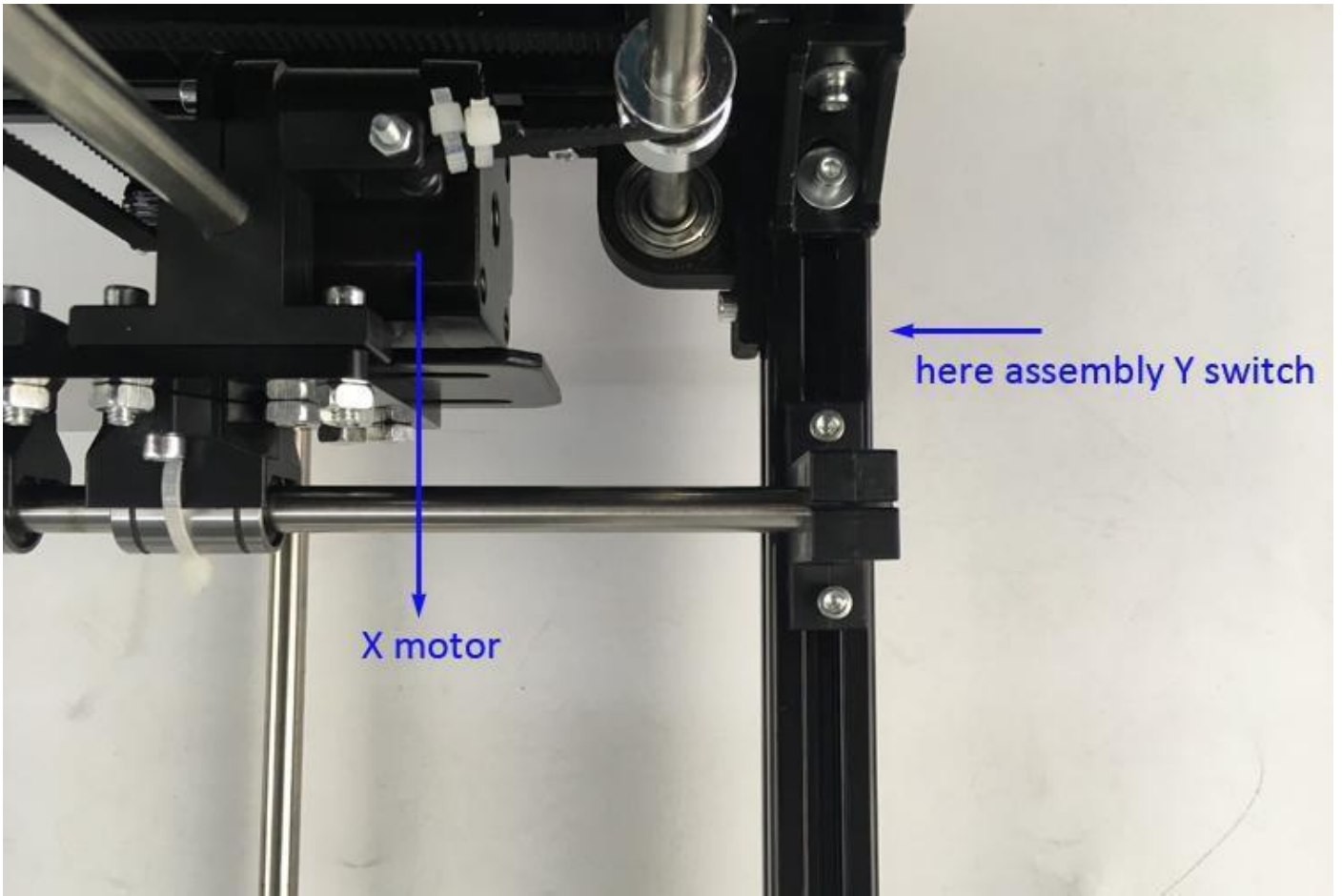



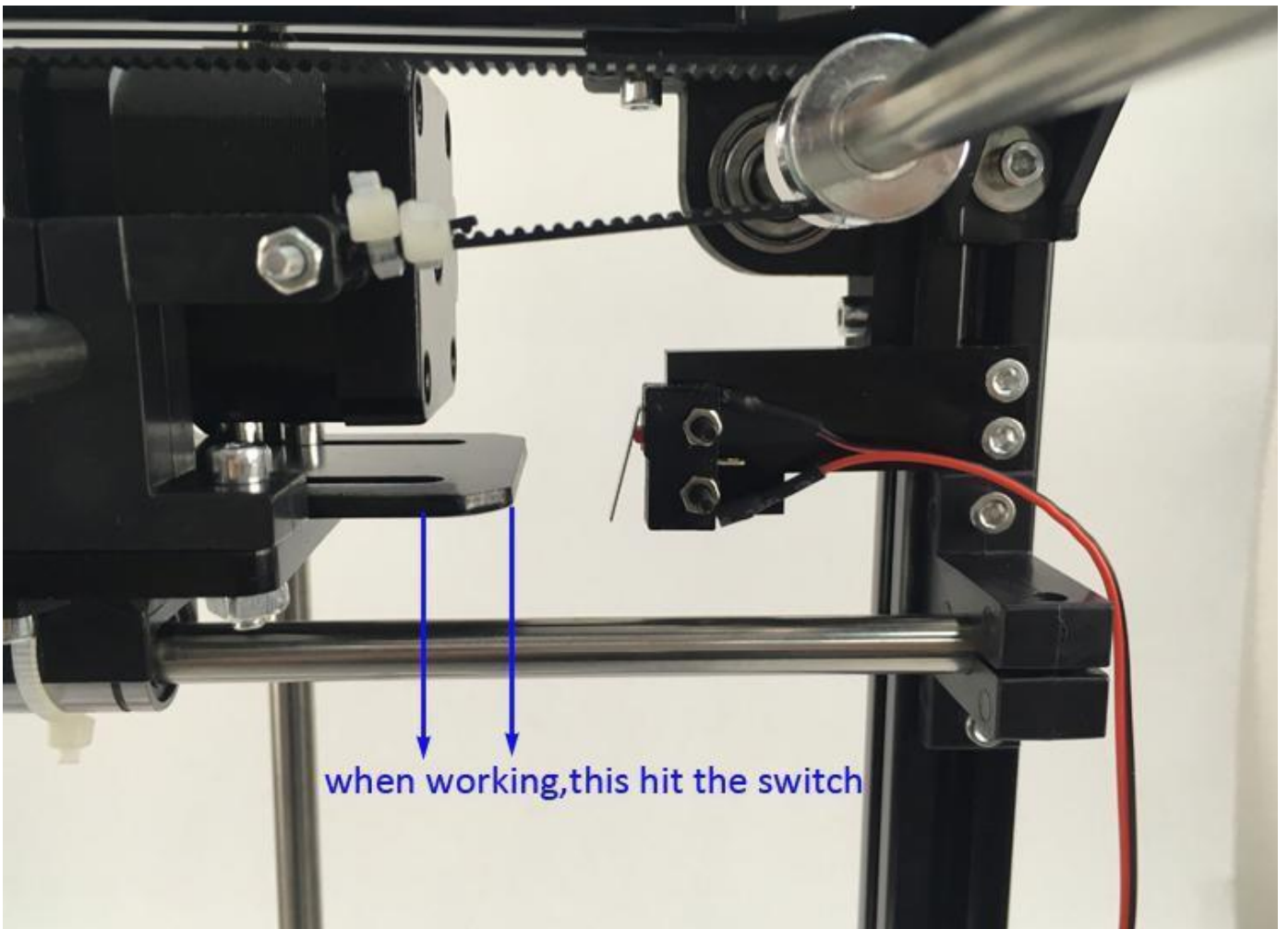
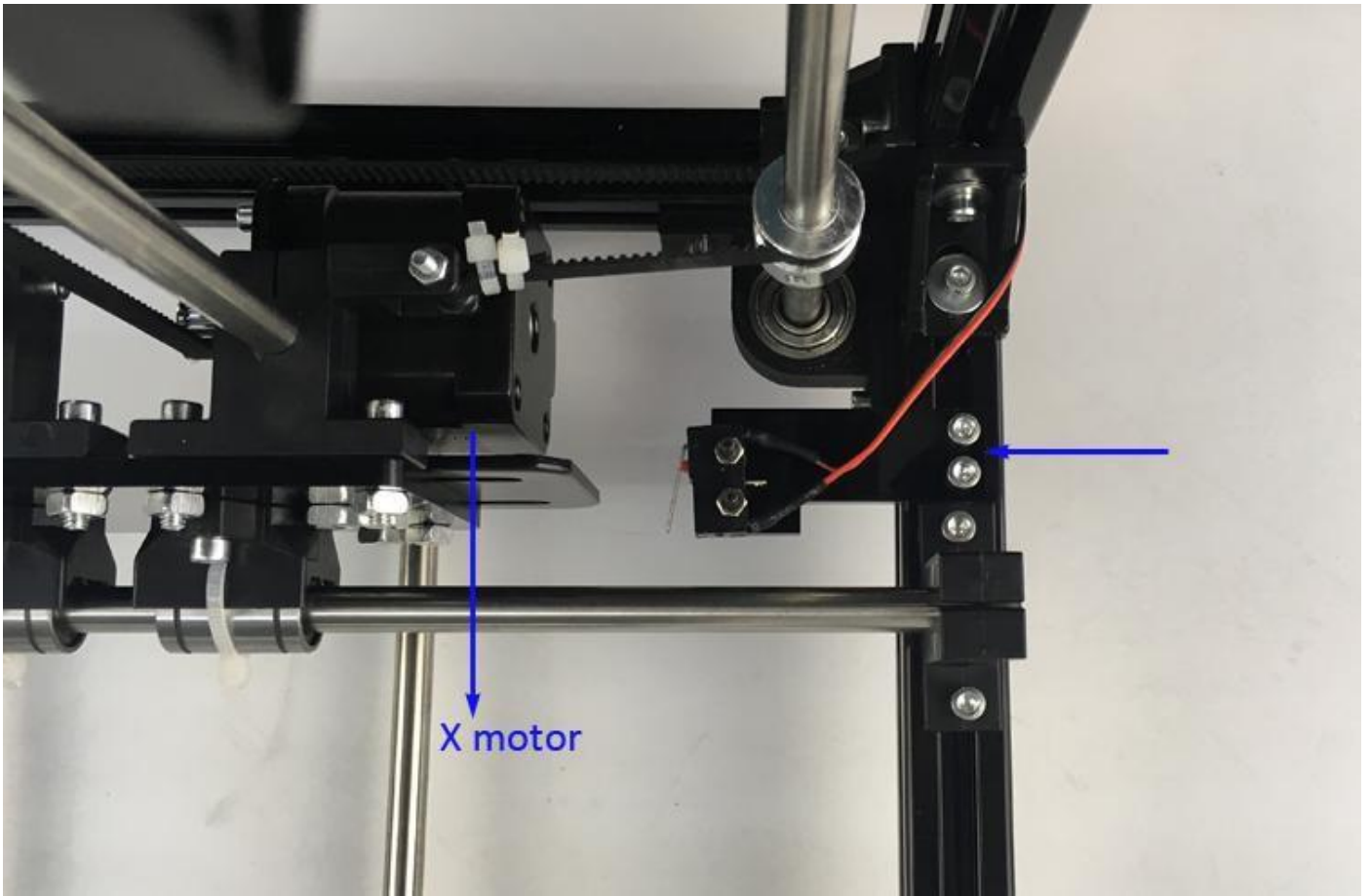

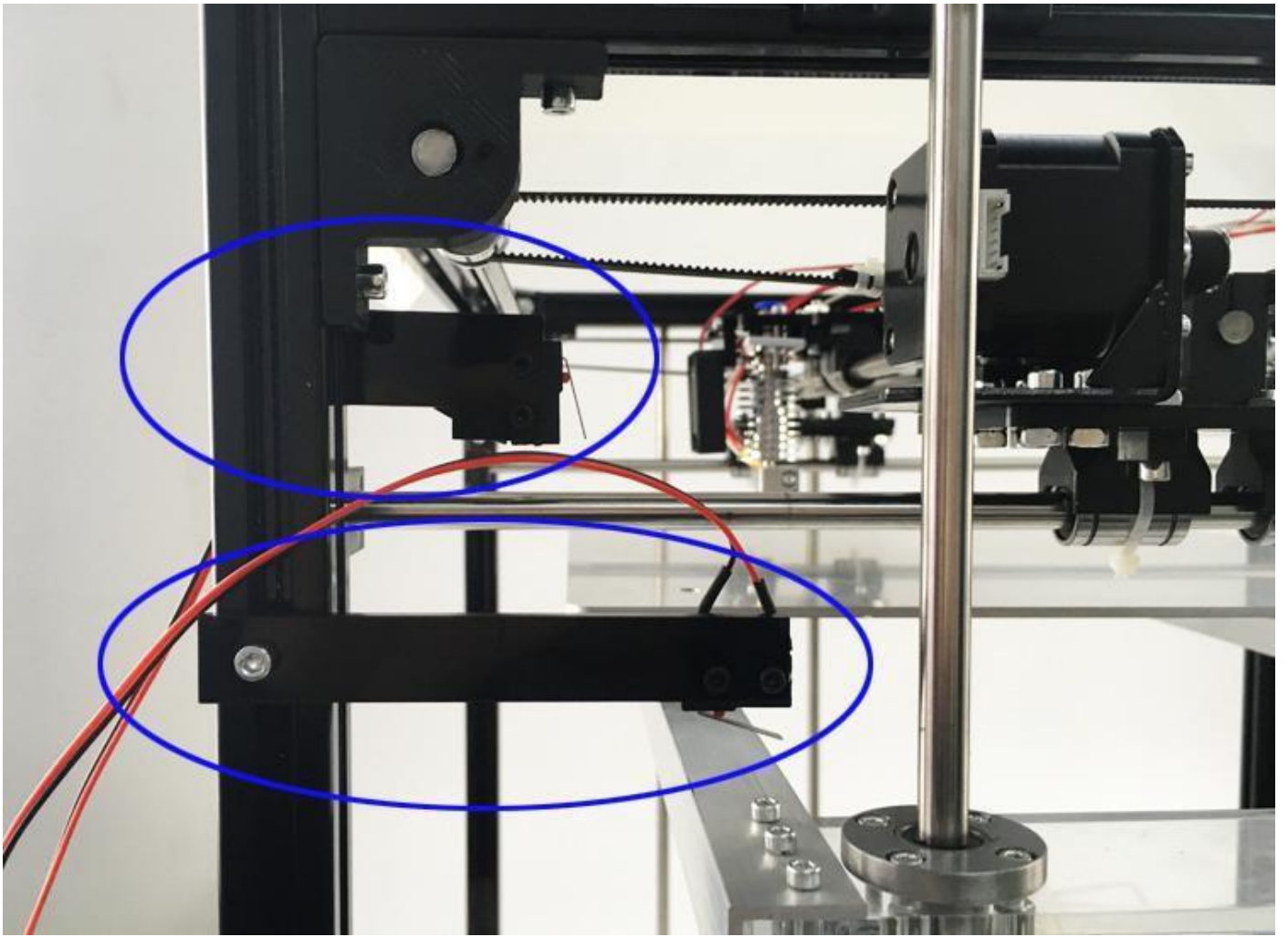

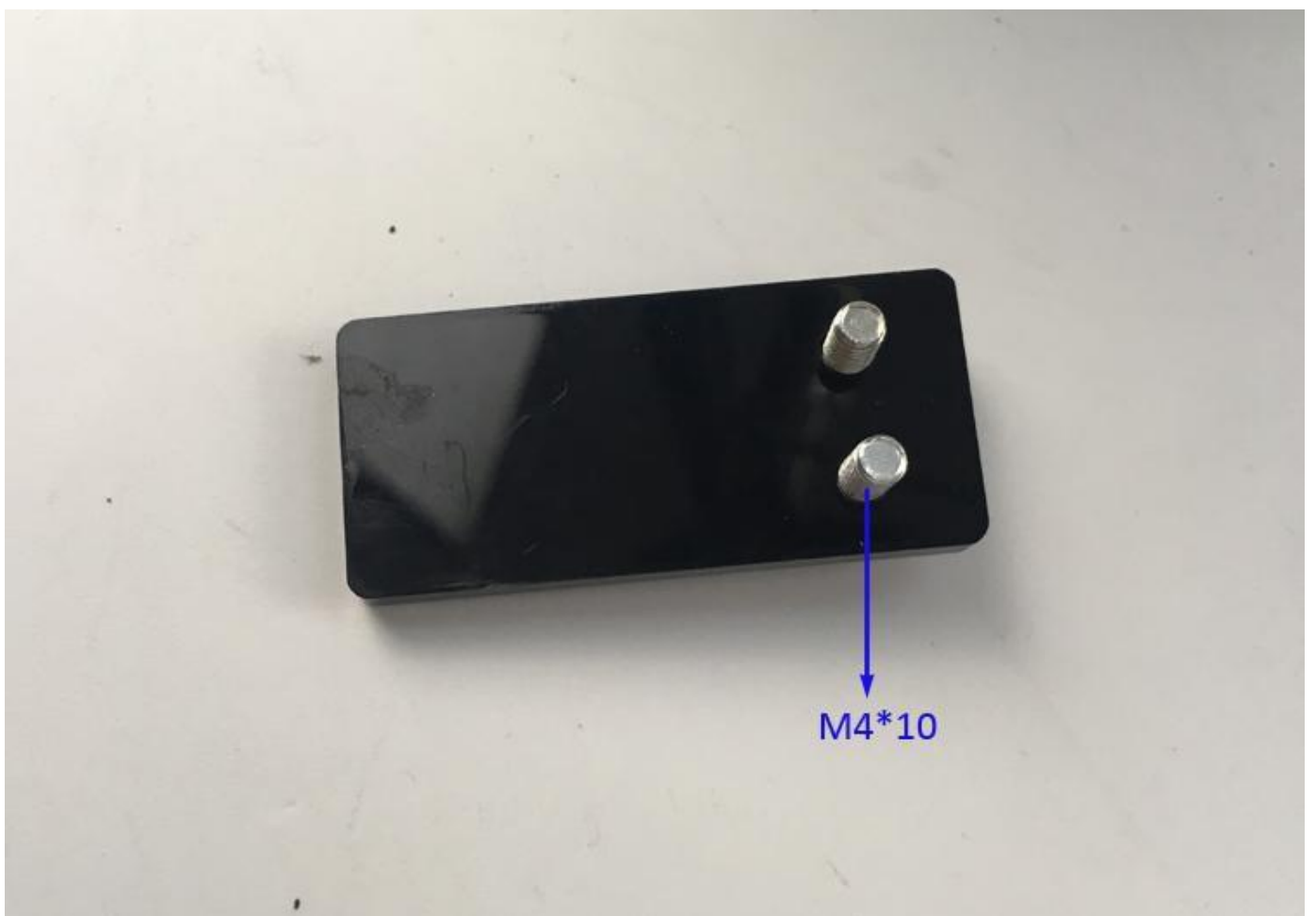
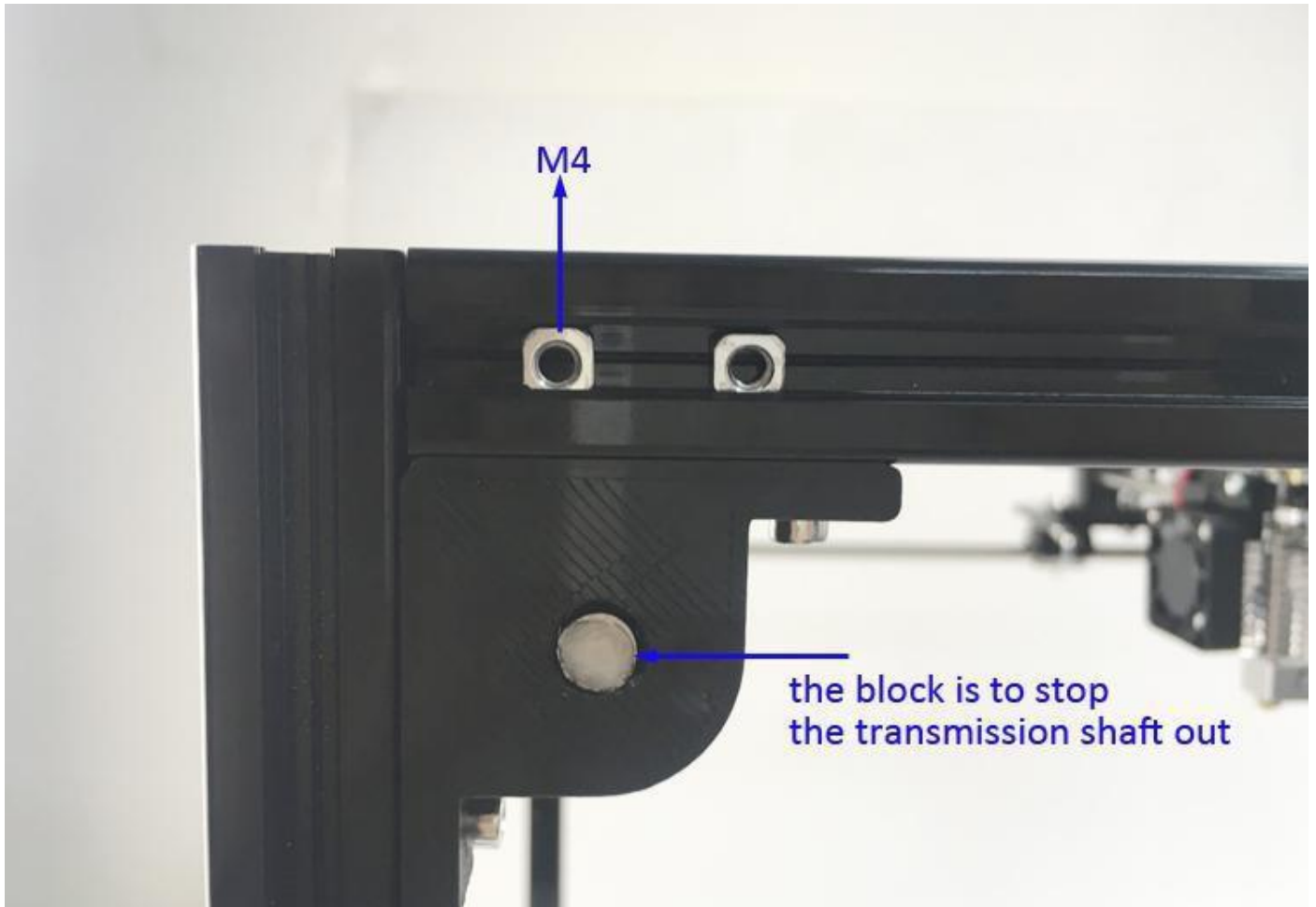

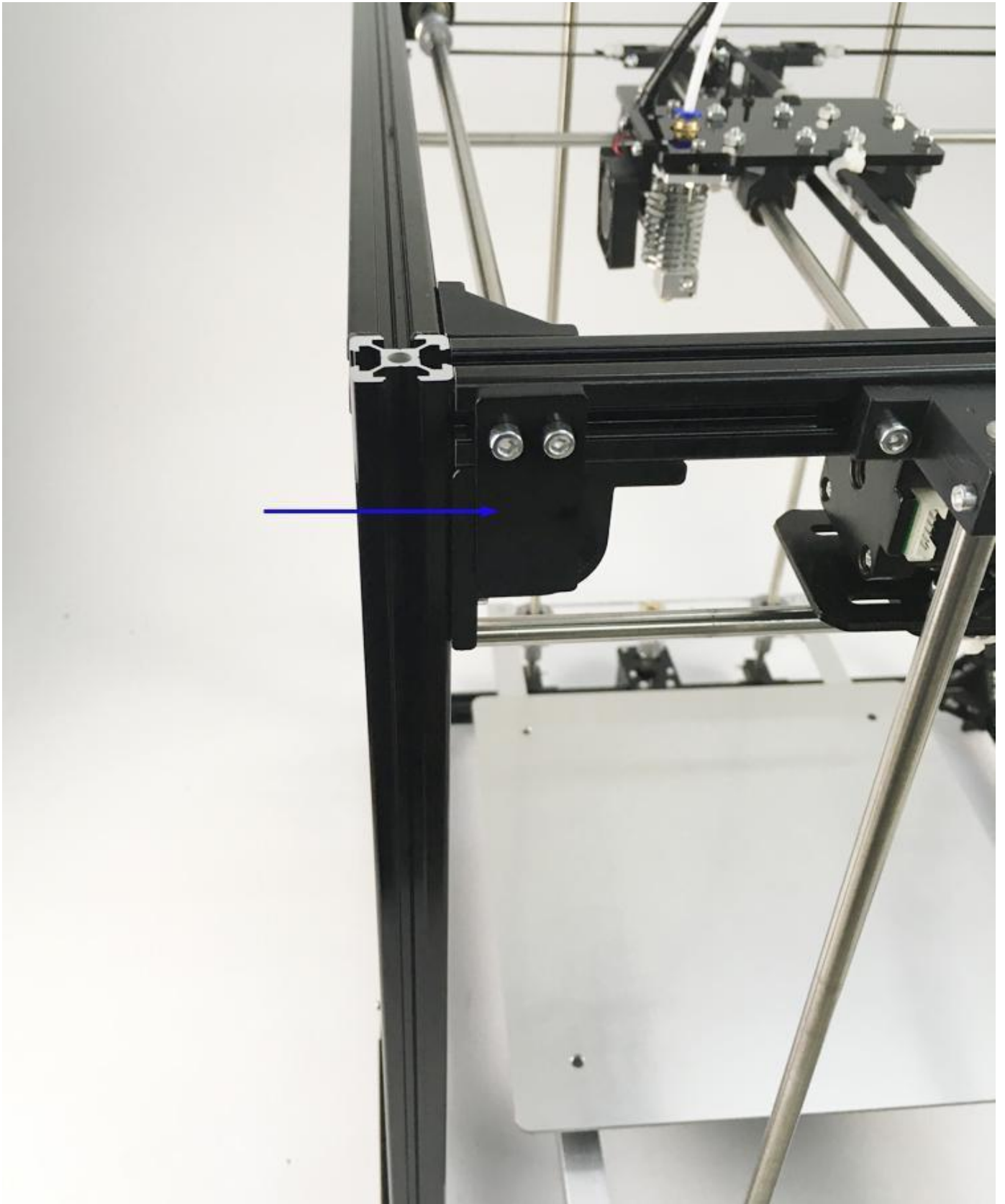

## 5 Assembly feeder motor

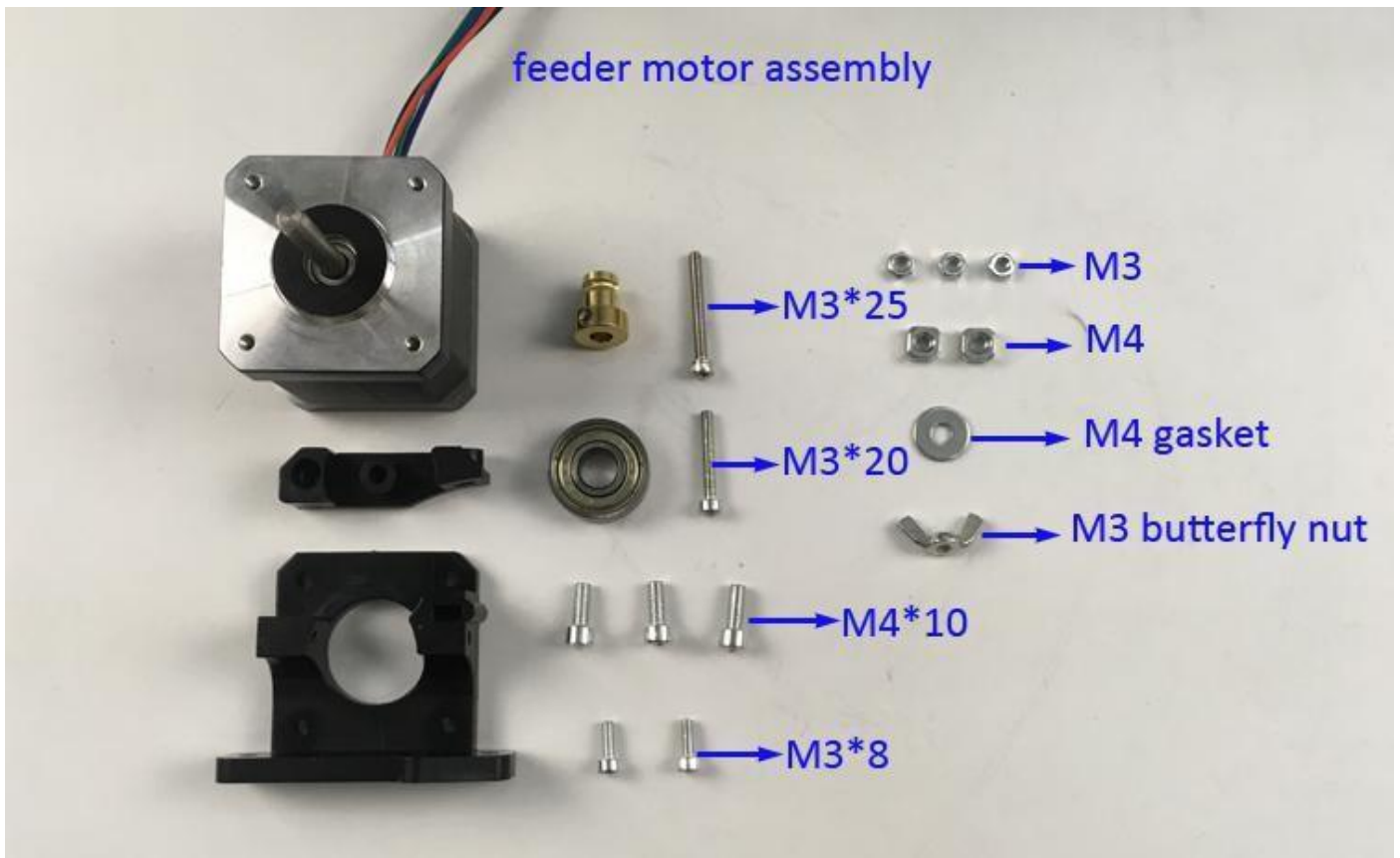



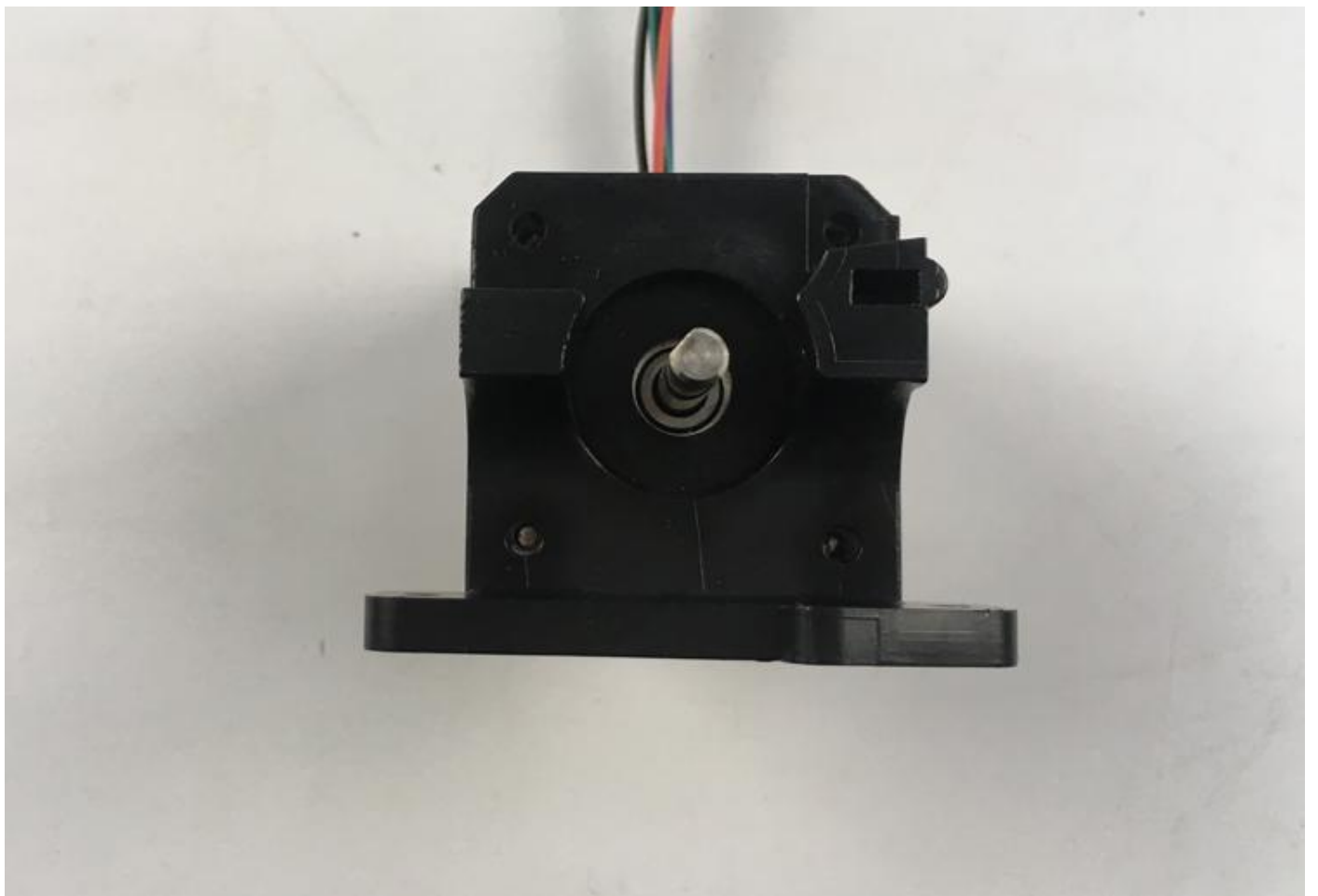
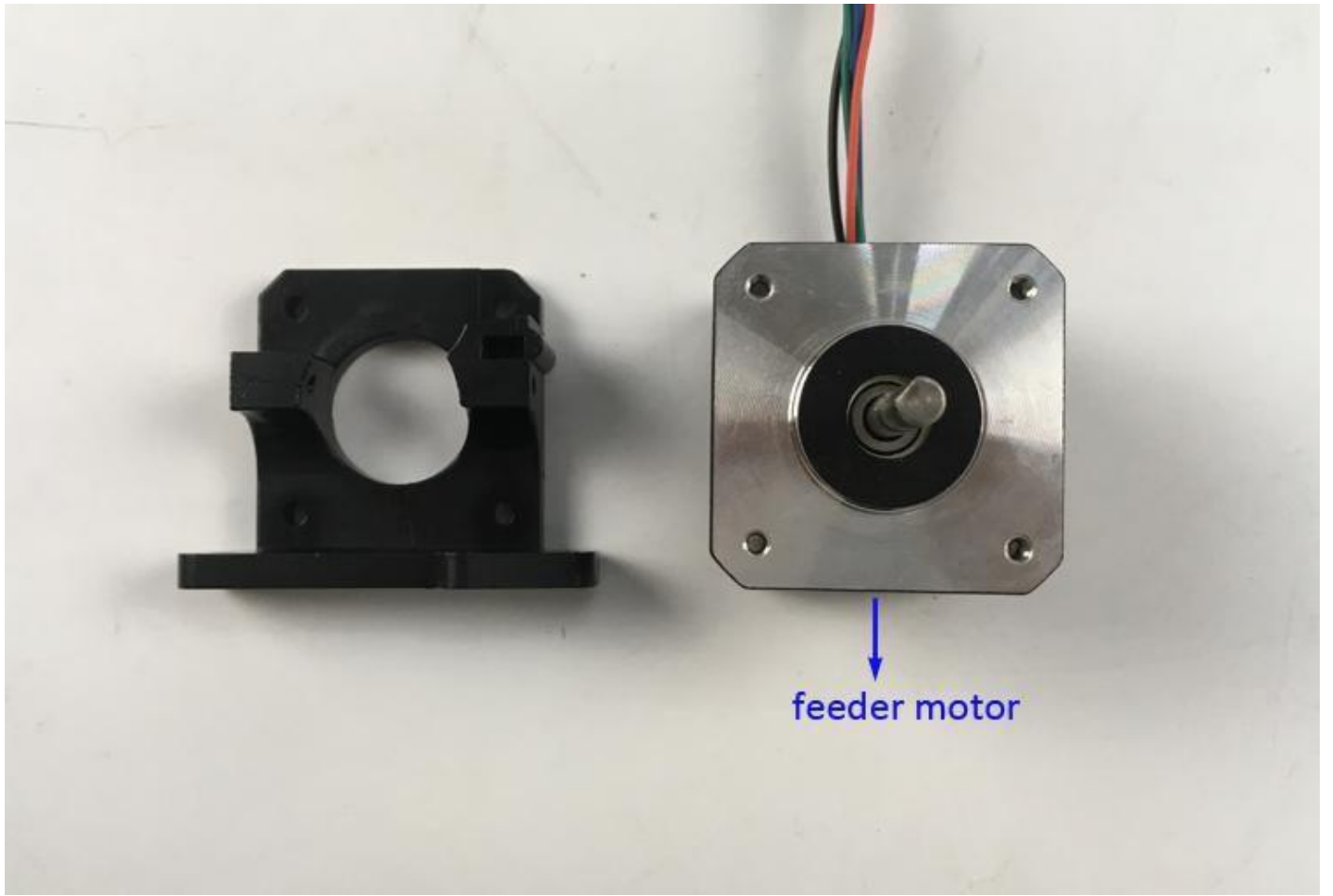

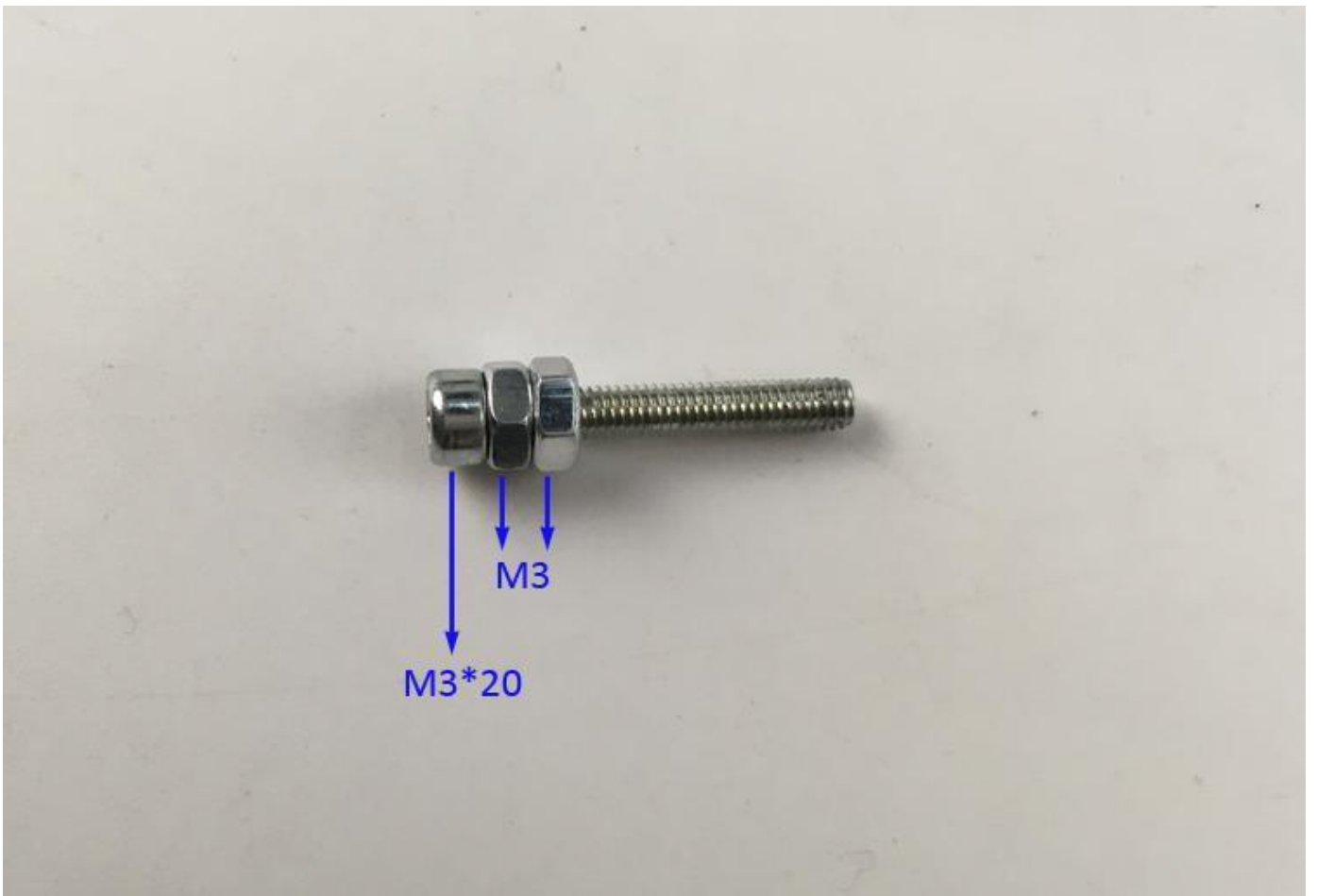
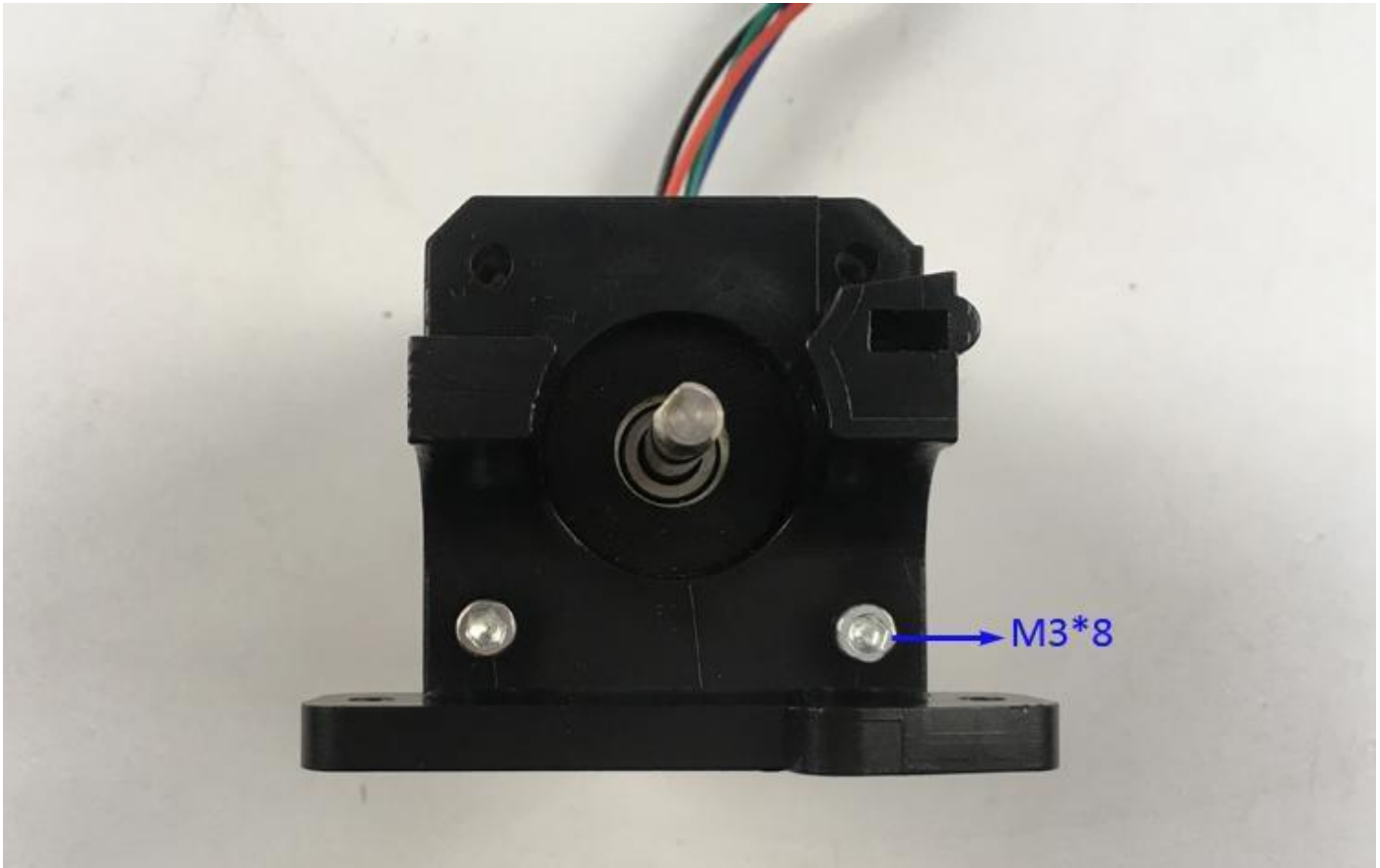



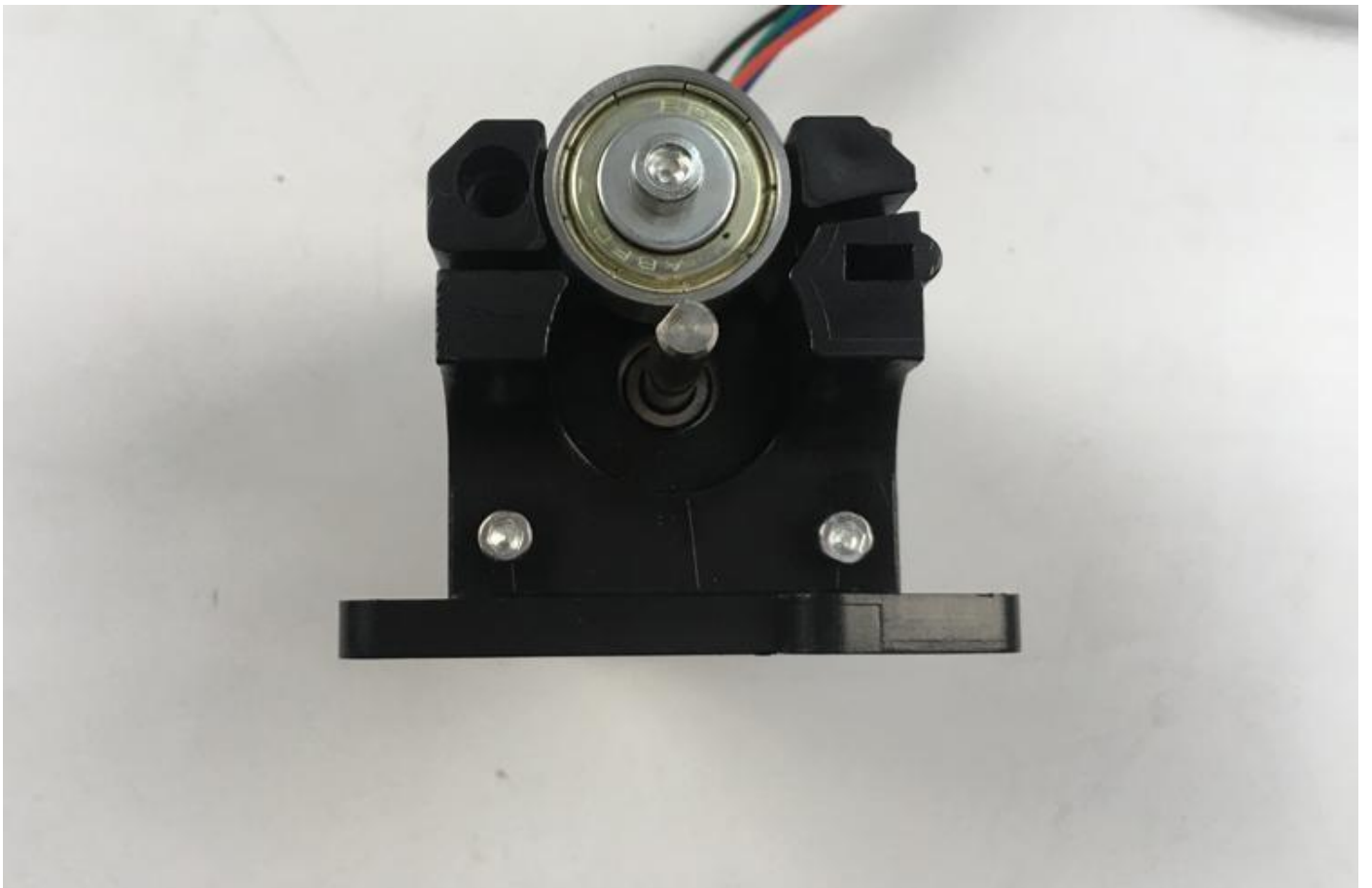

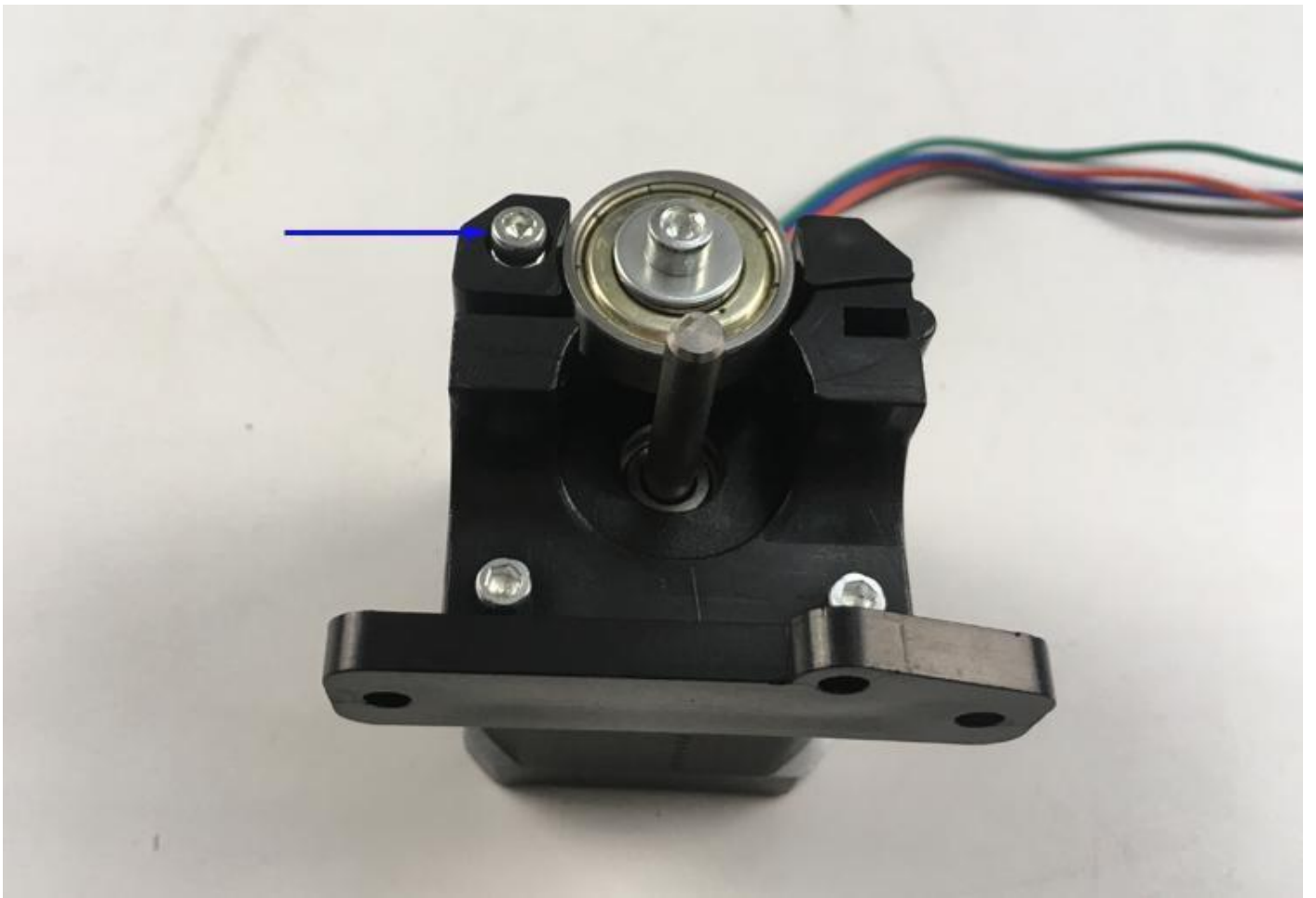

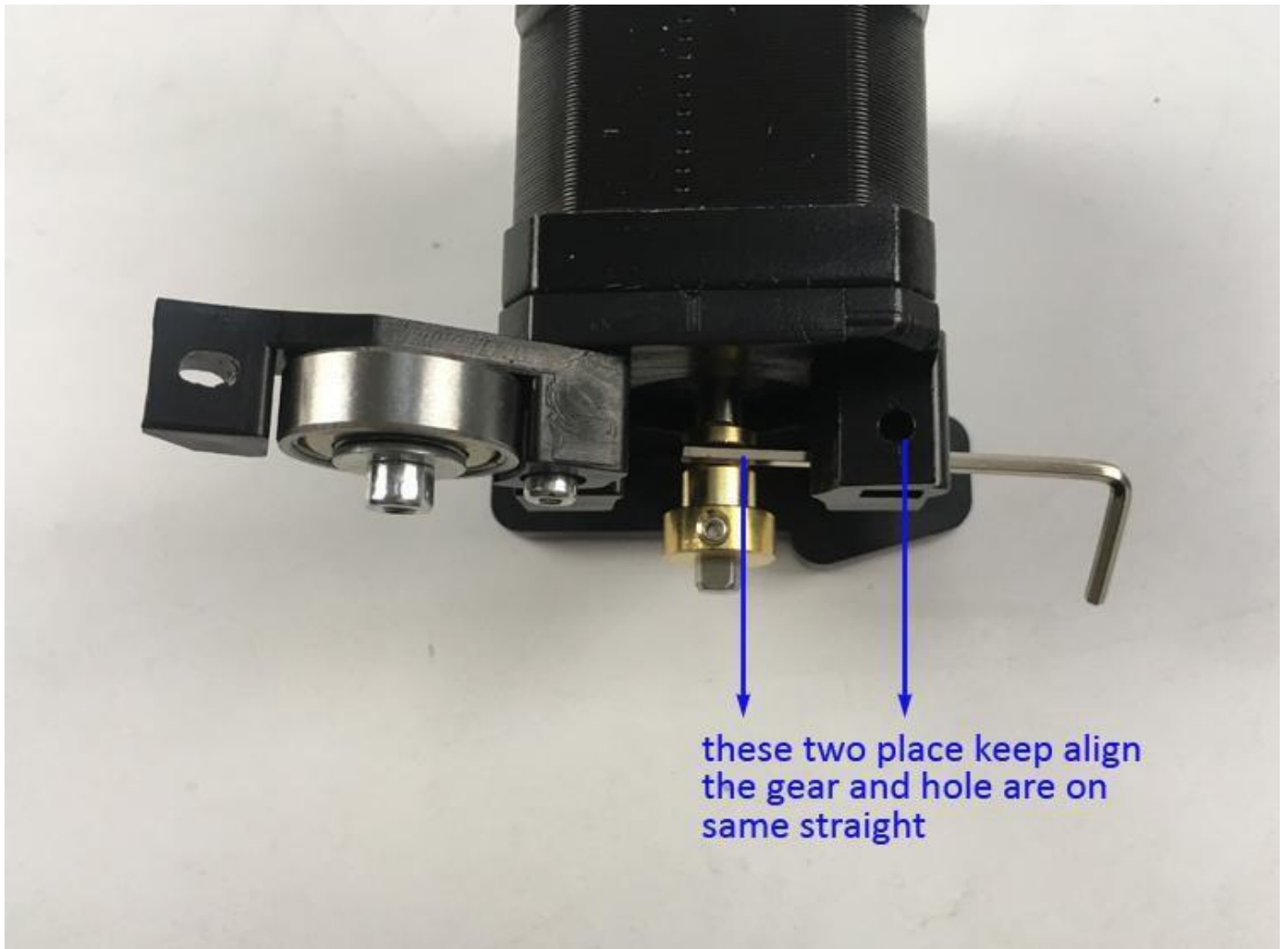

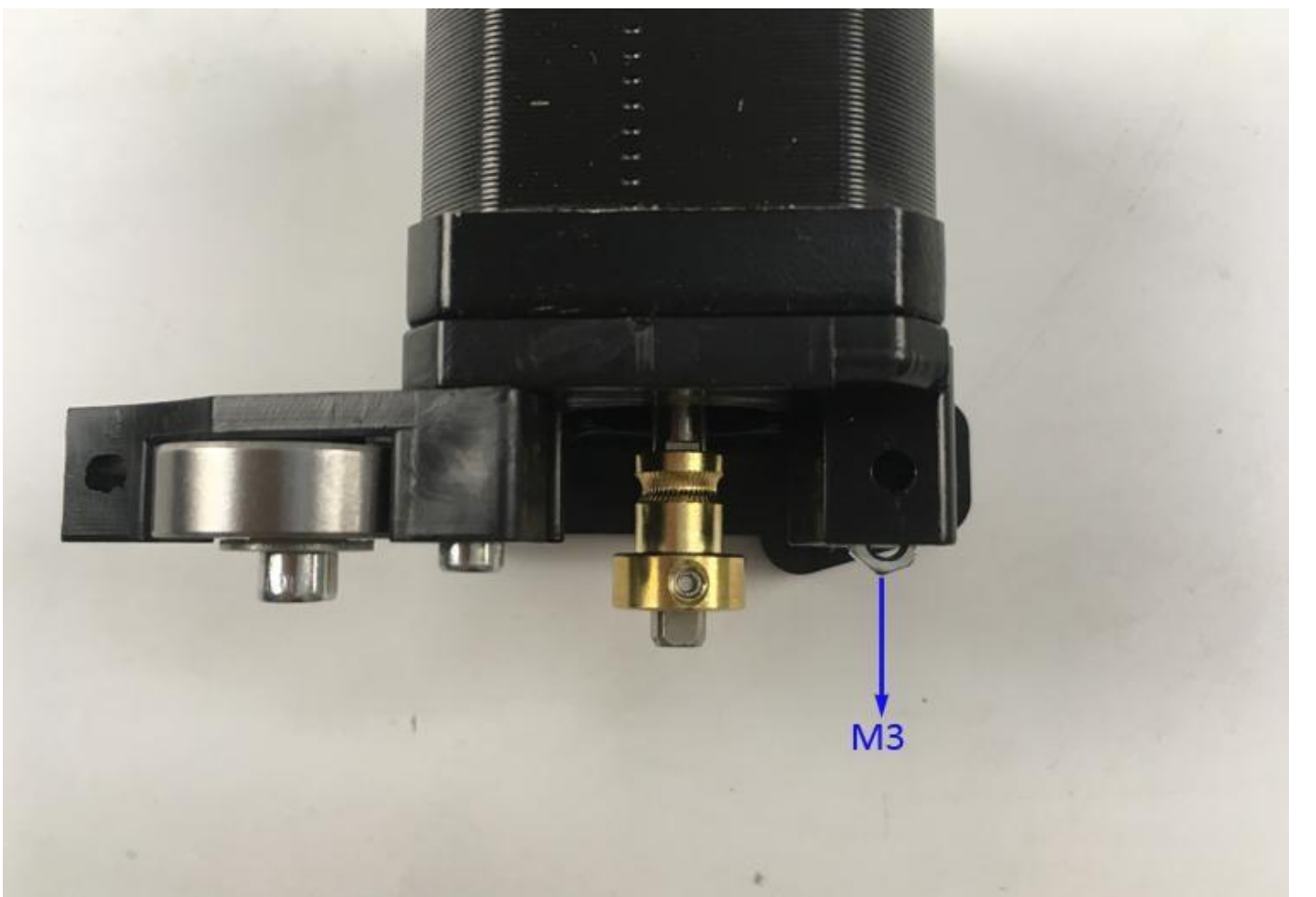

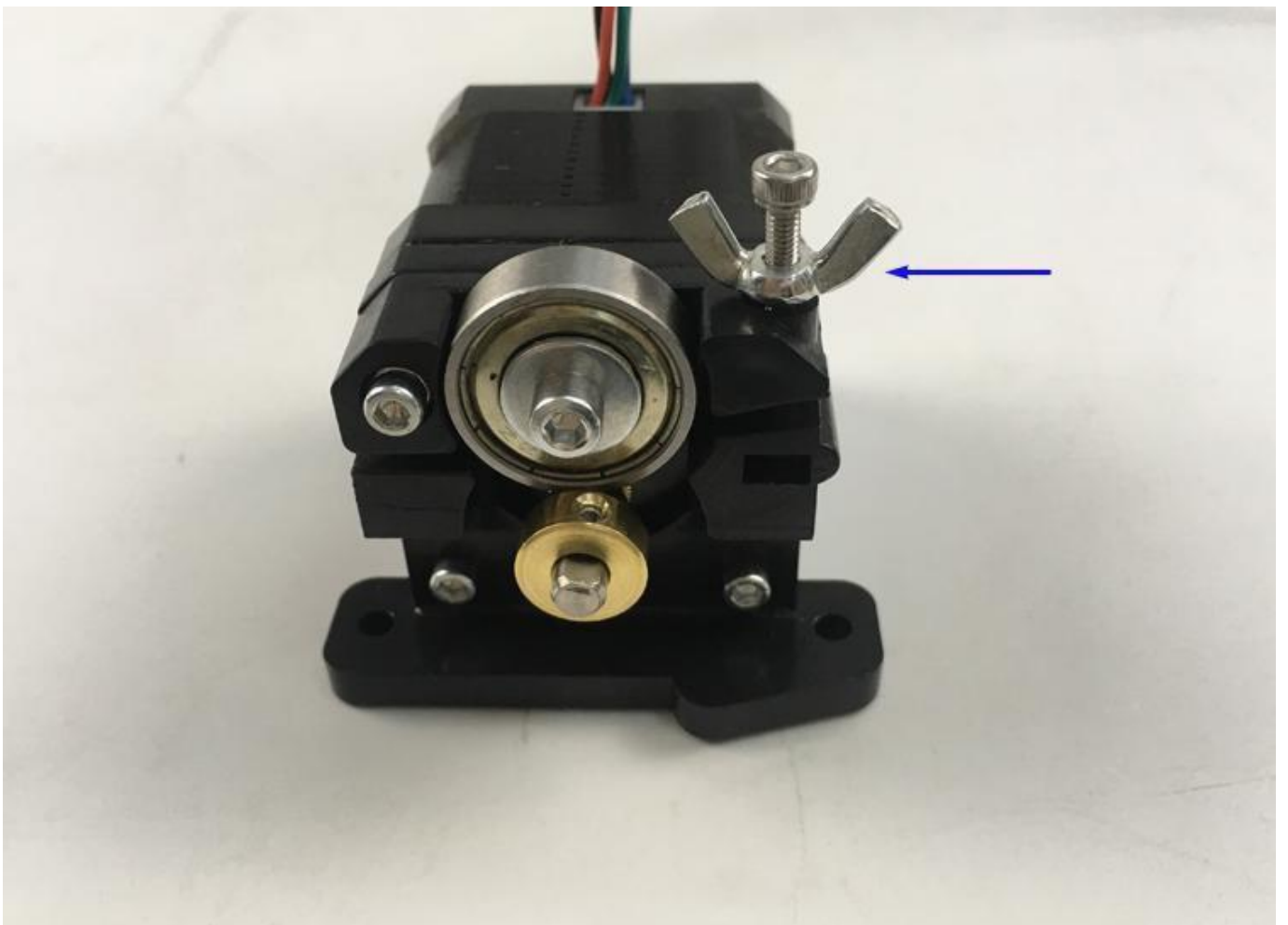
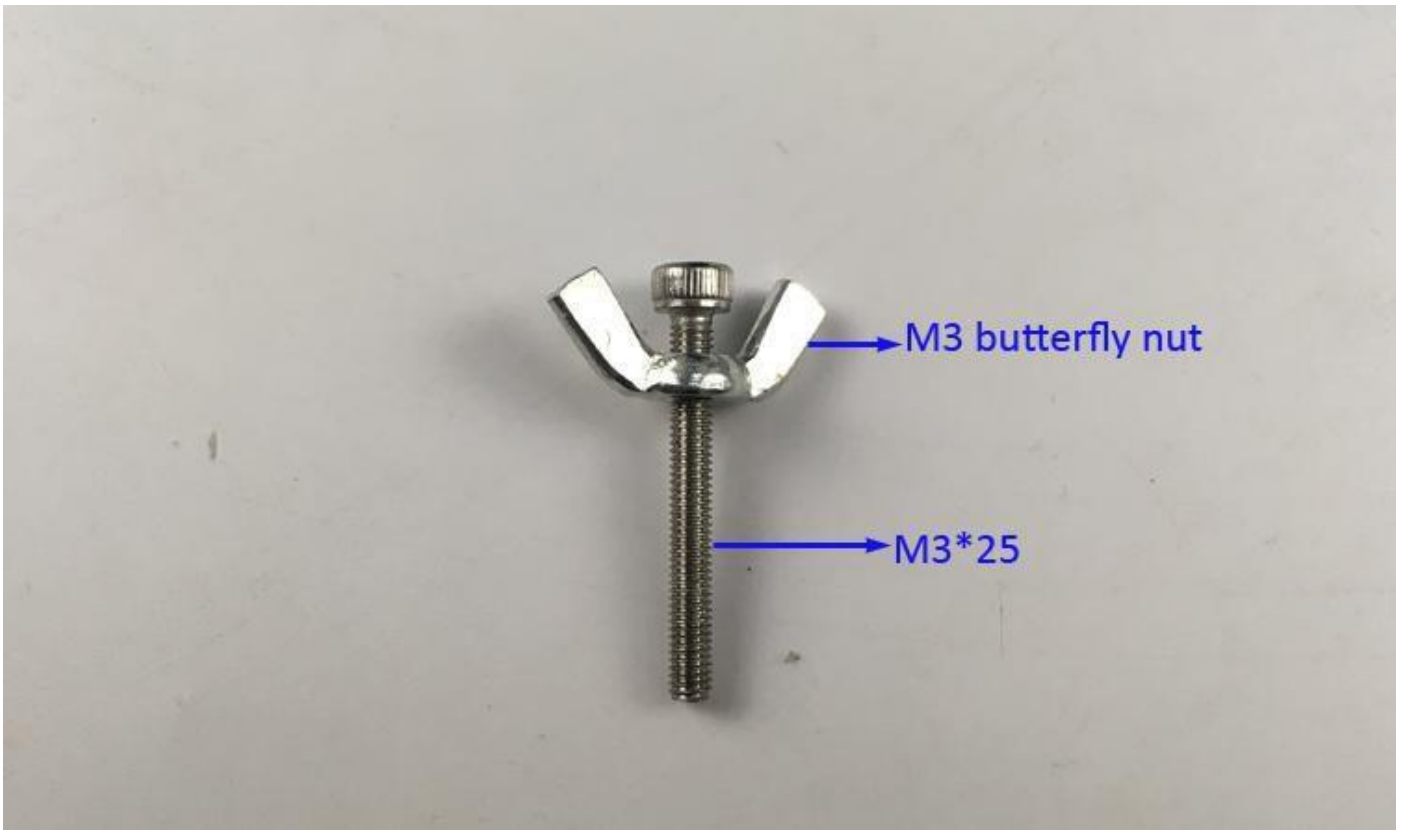

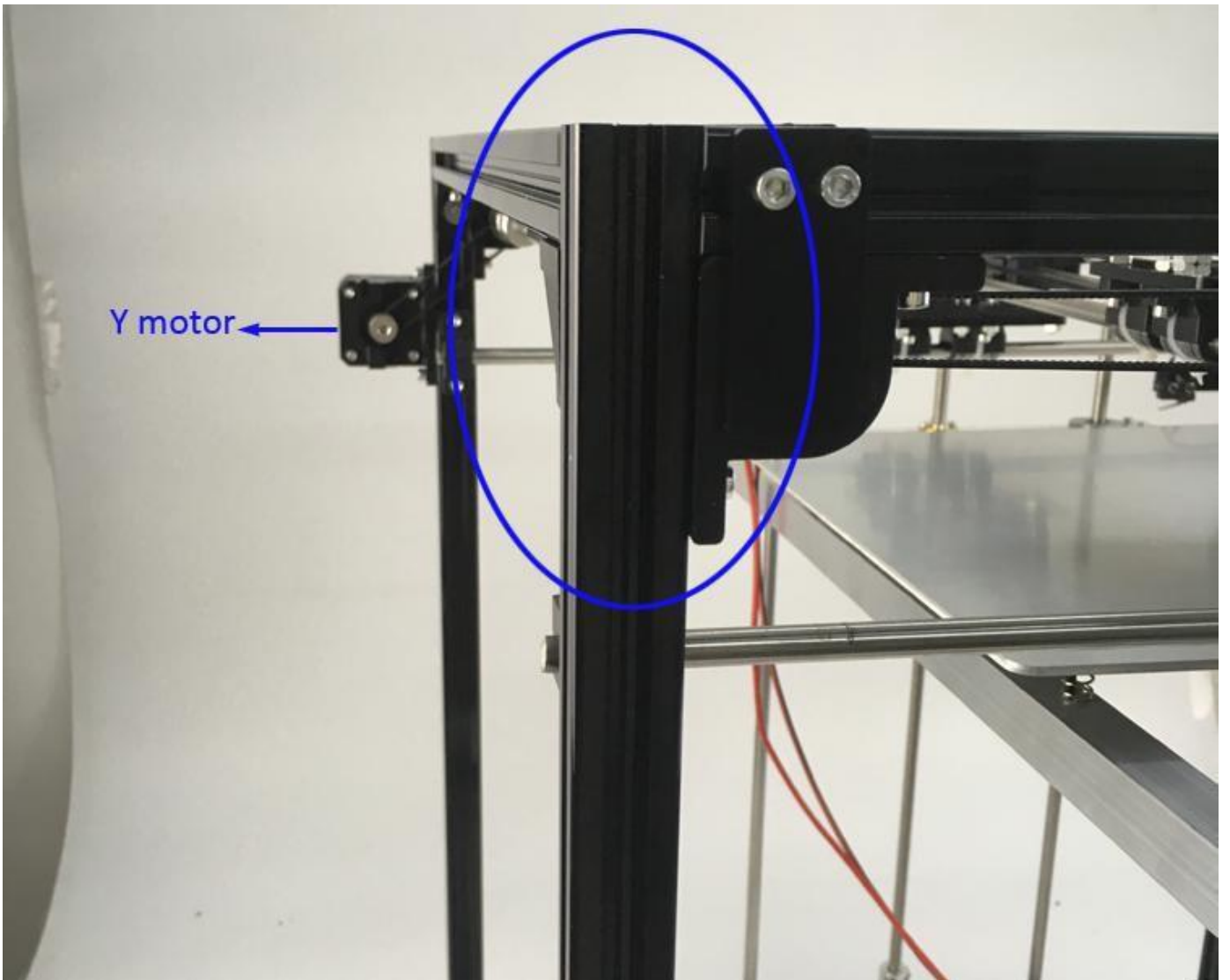
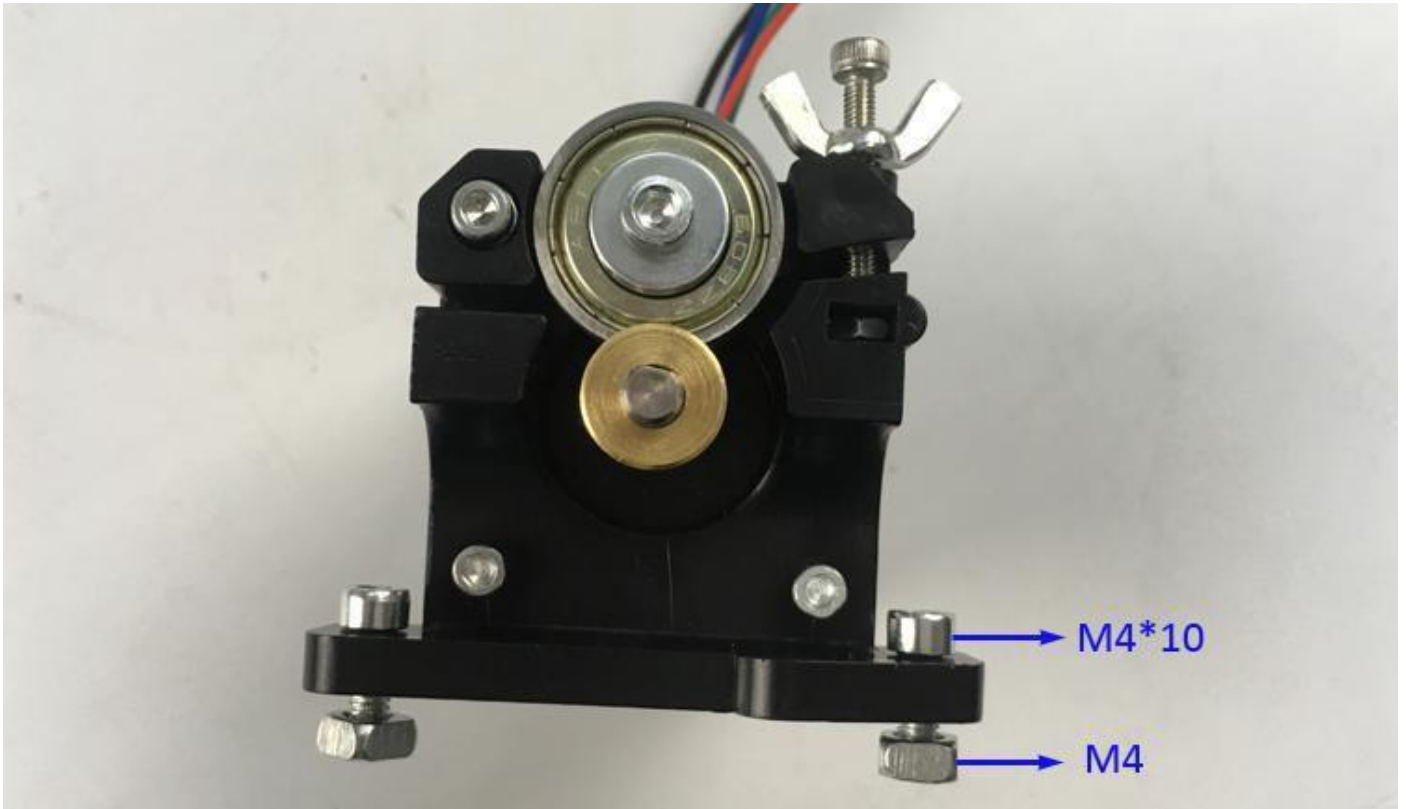

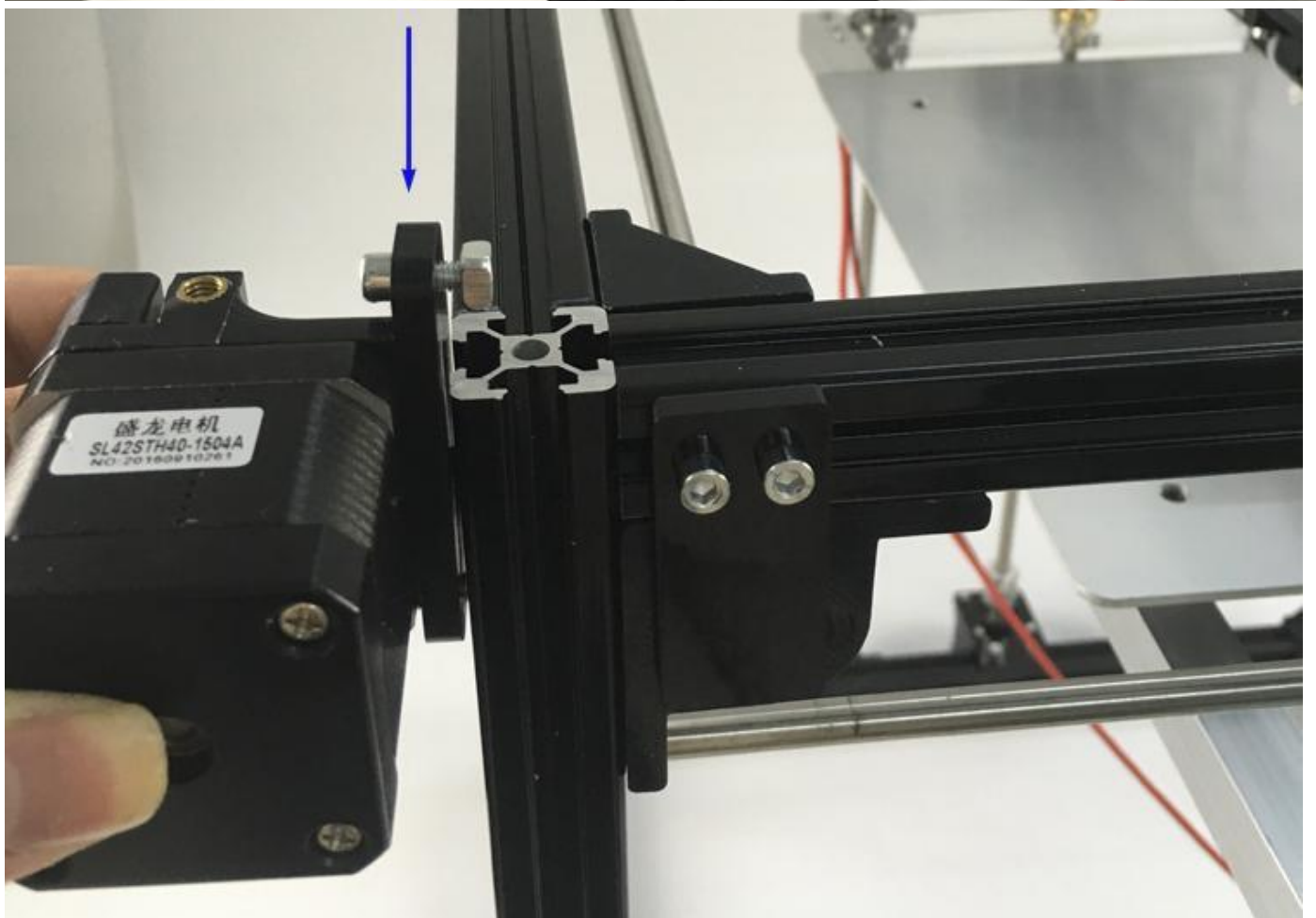
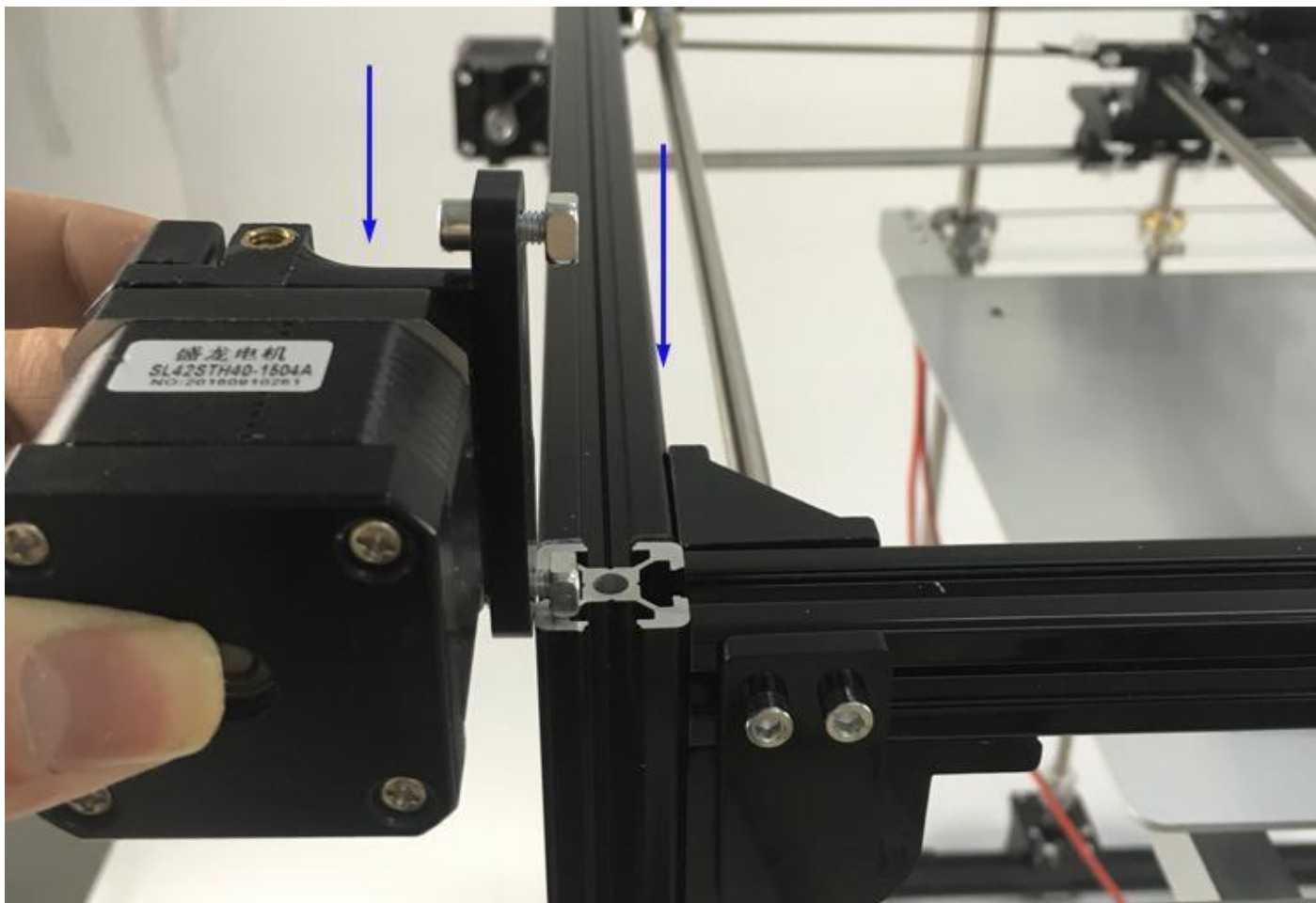

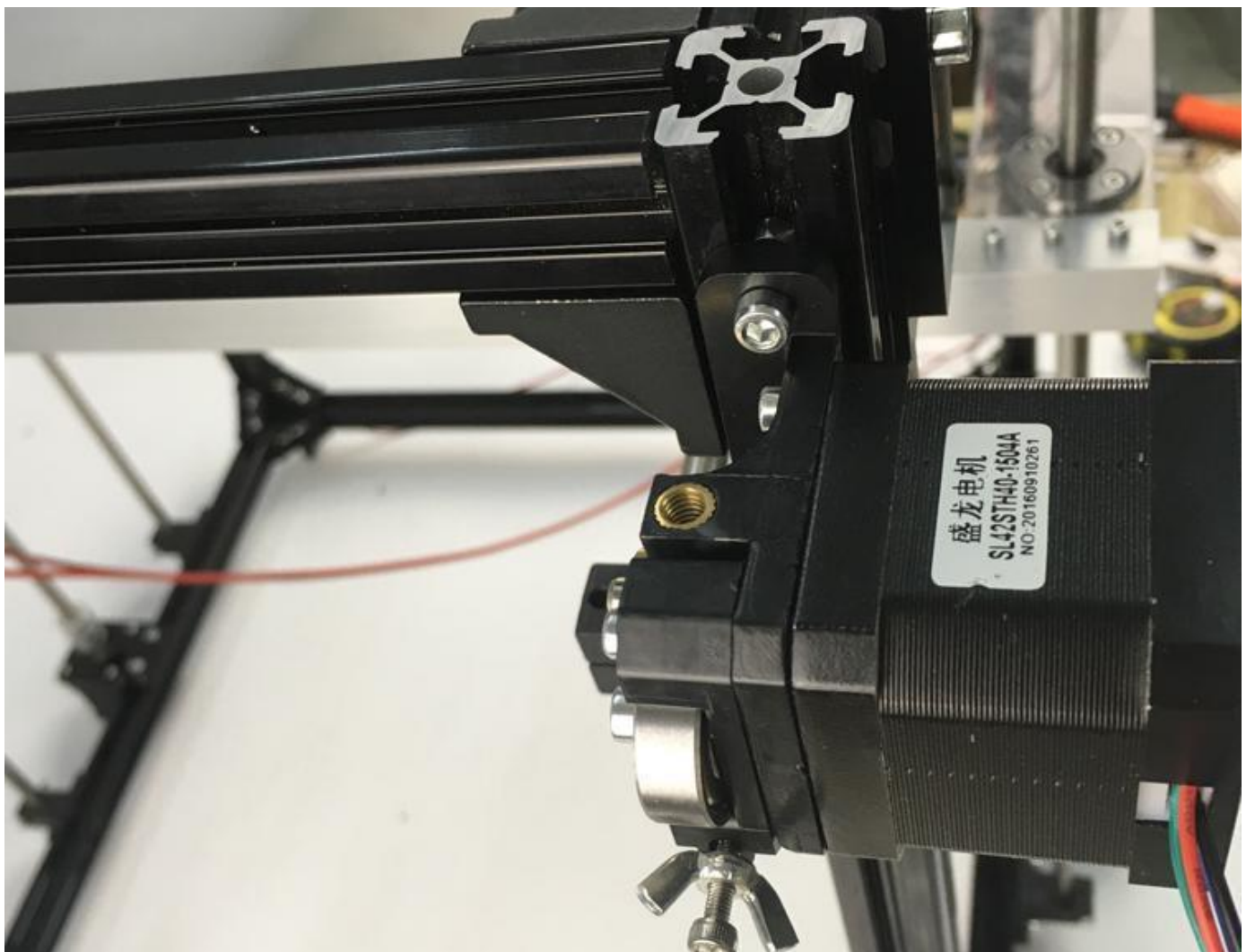
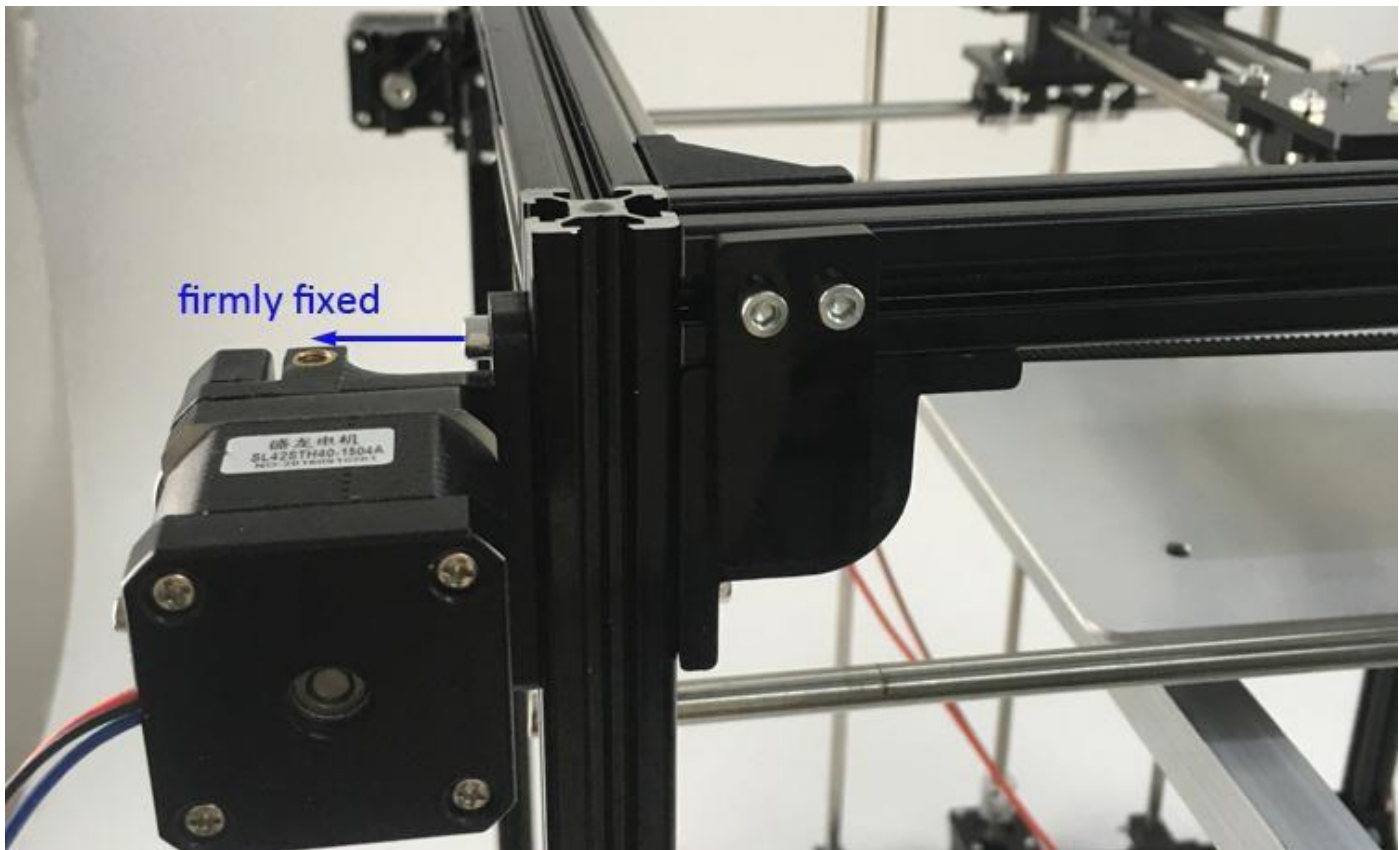



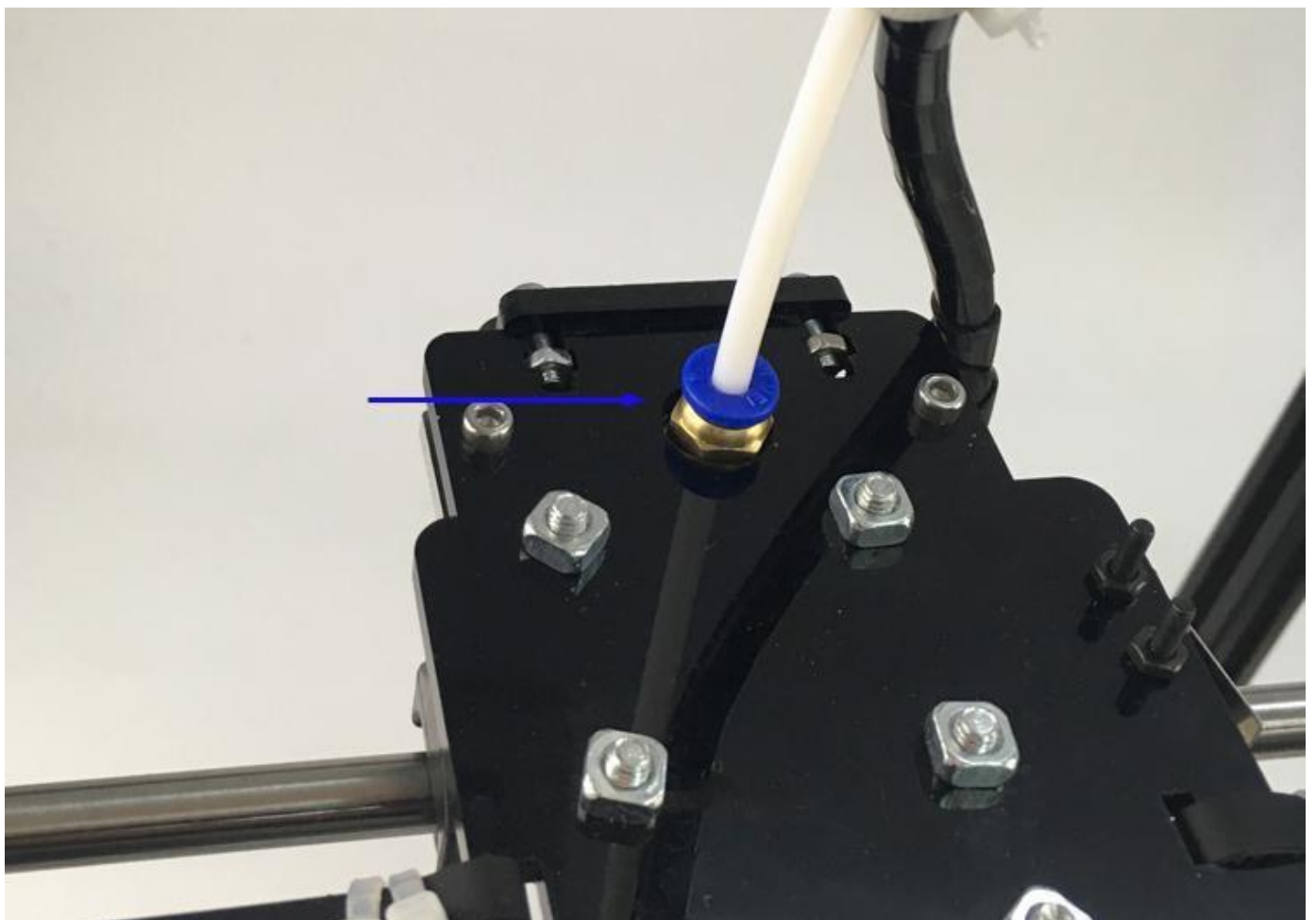
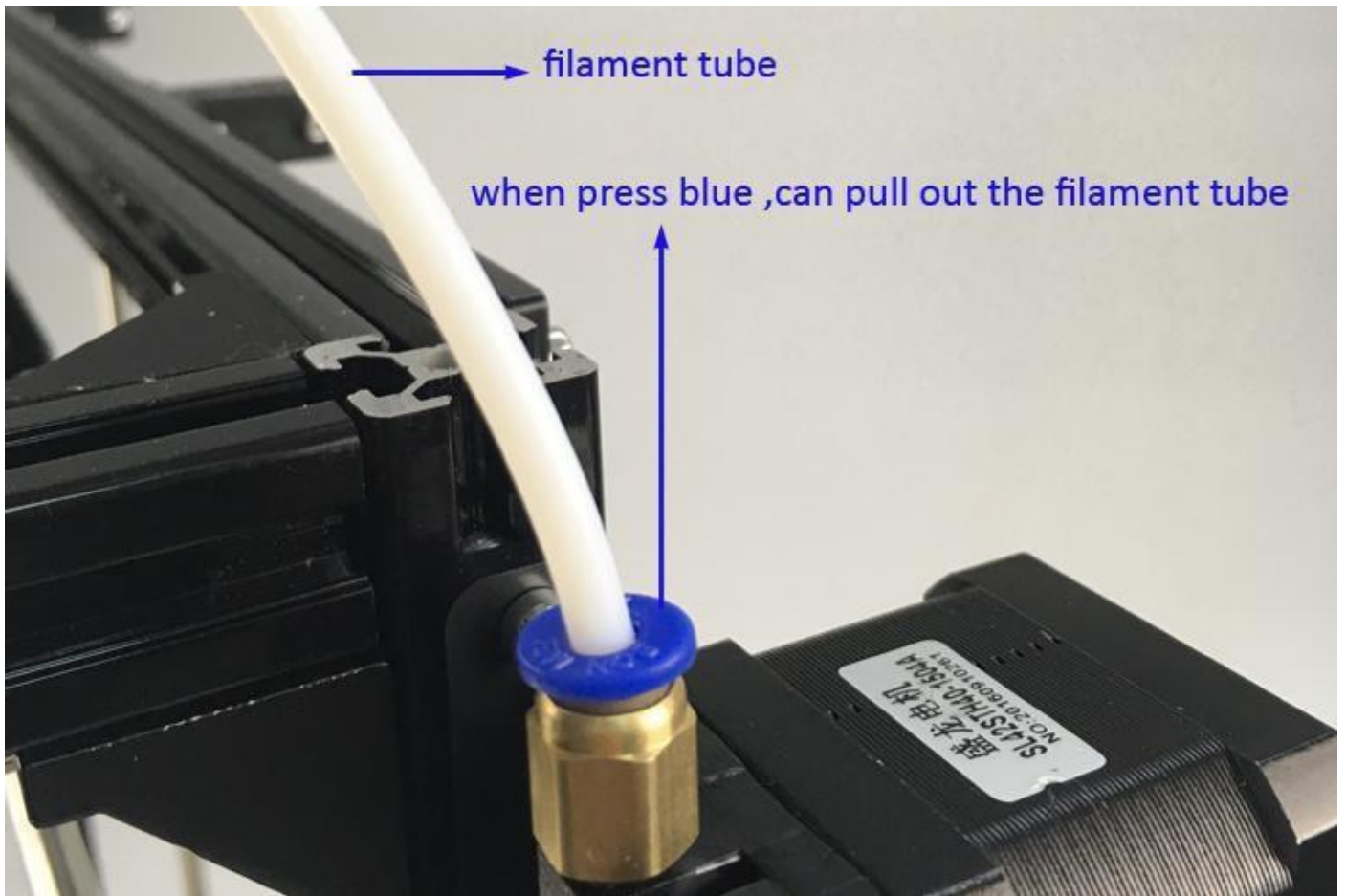

## 6 Assembly board, LCD and power supply

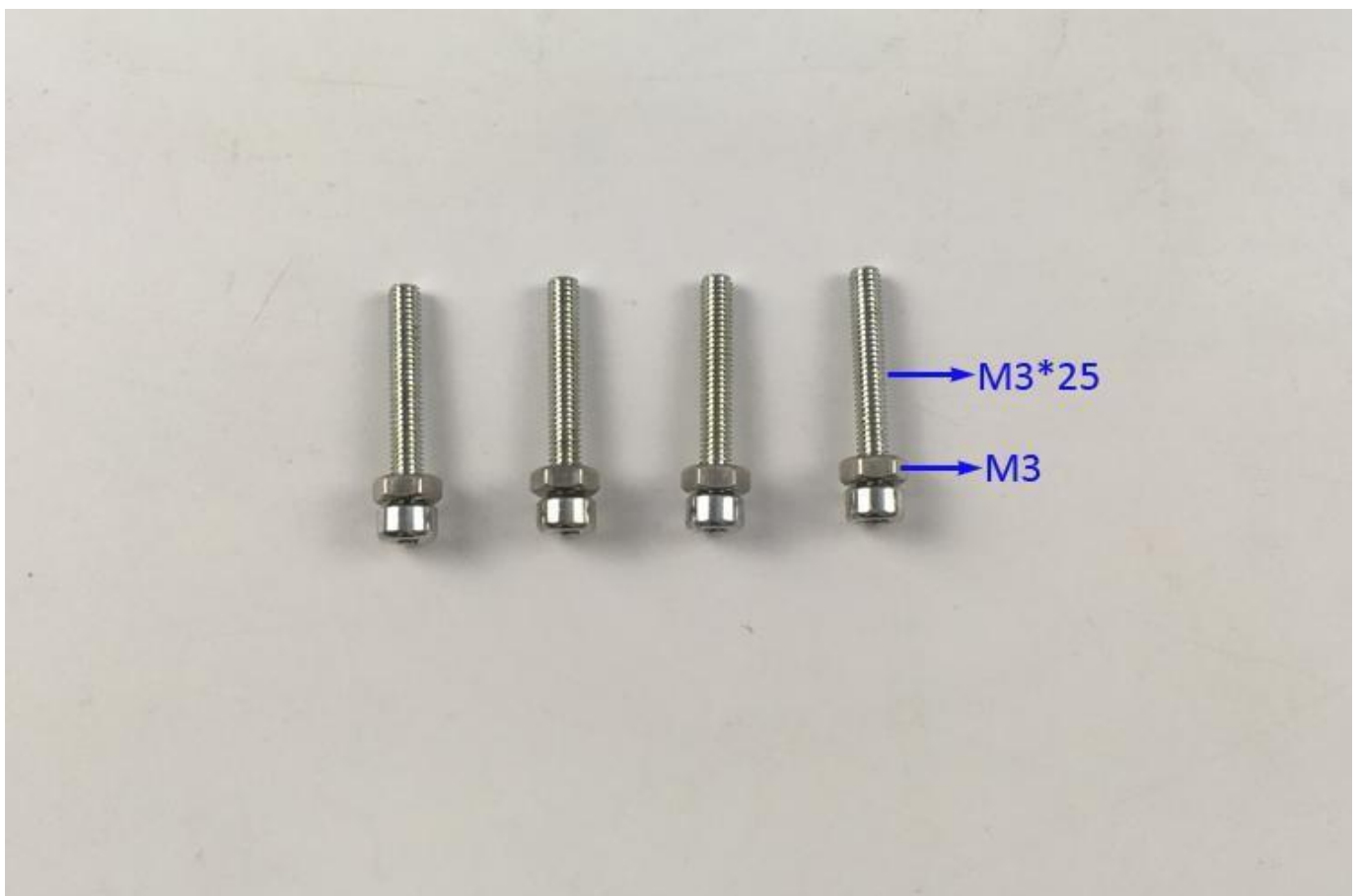
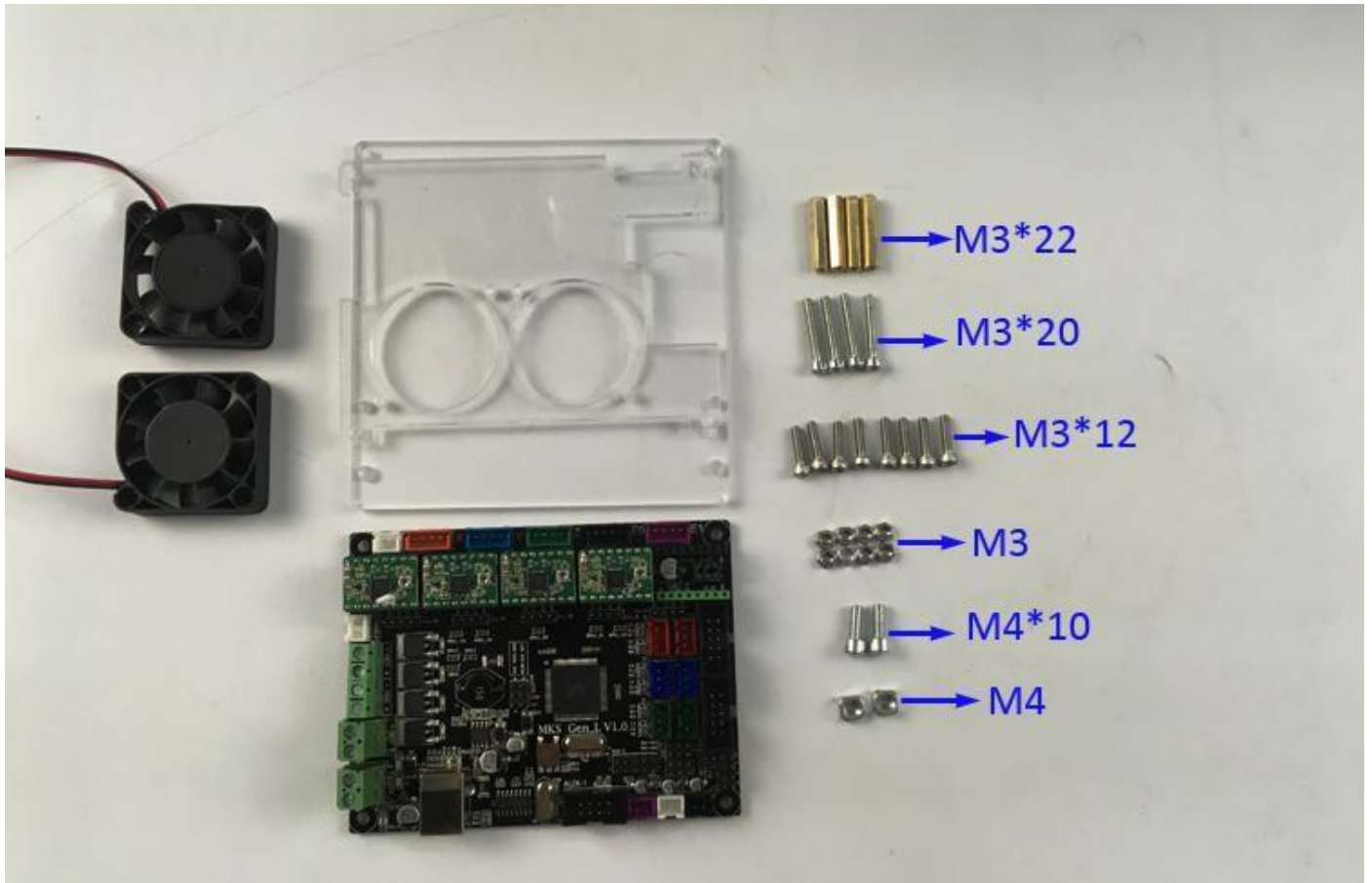

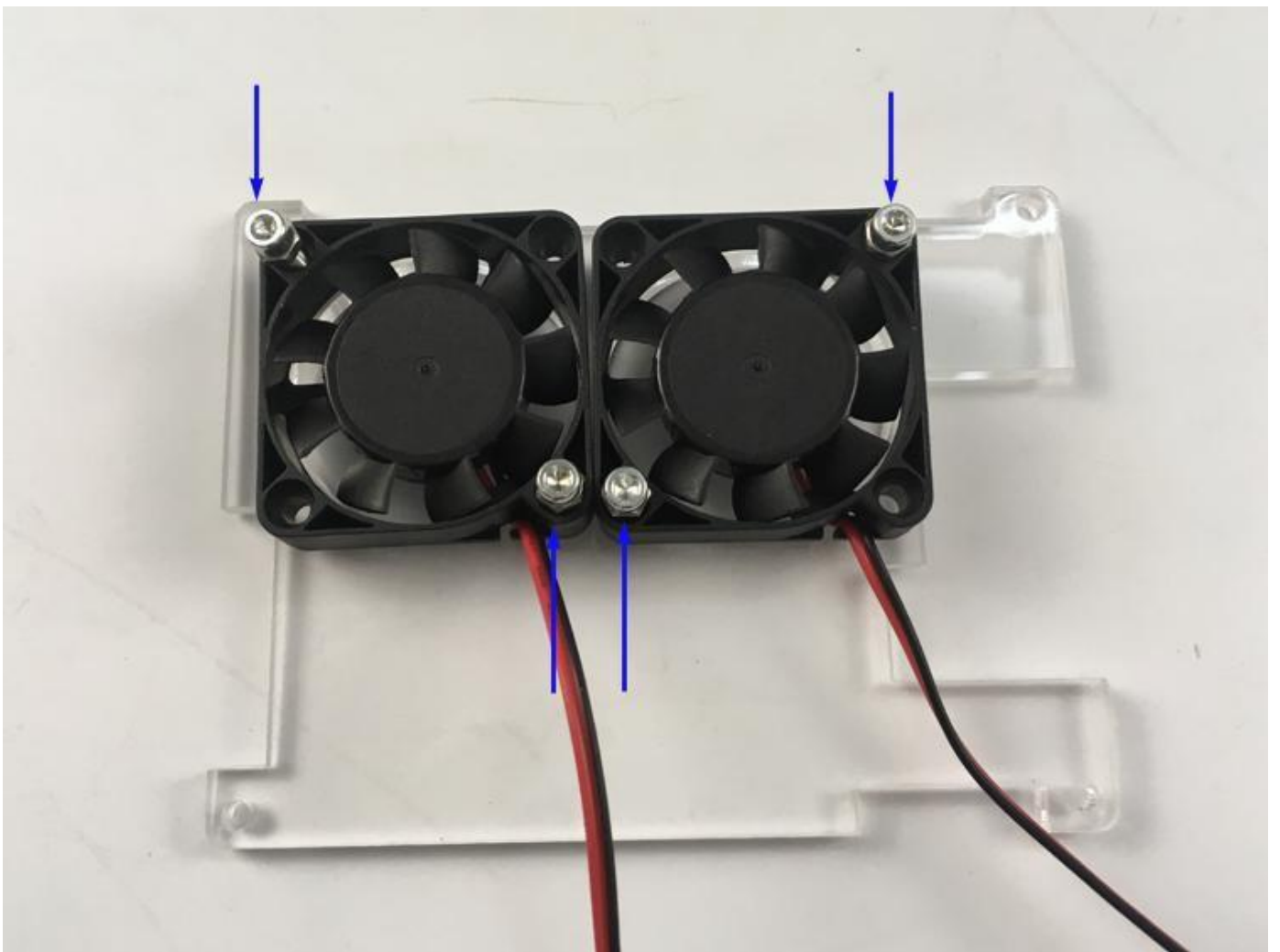
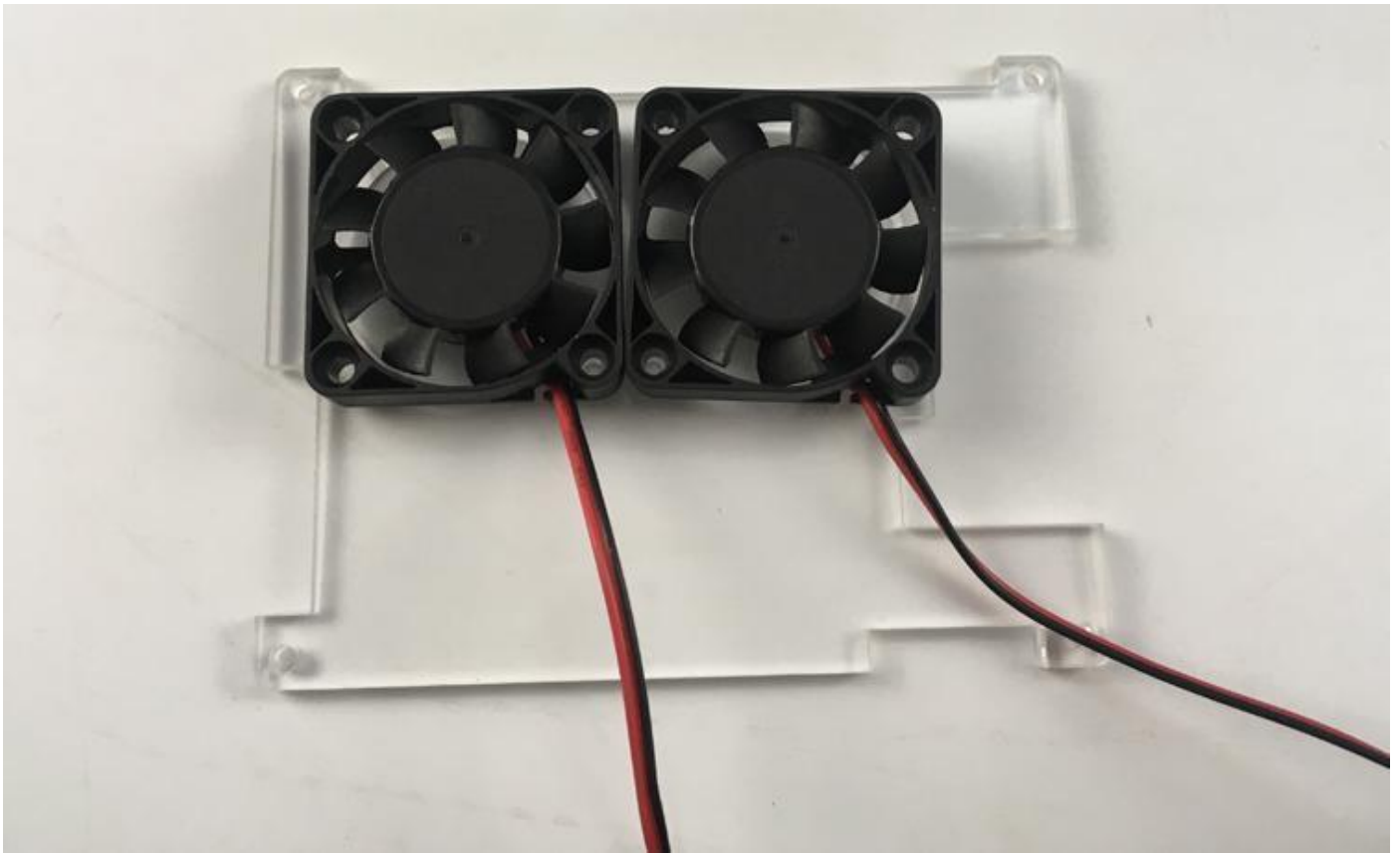

M3 firmly fixed

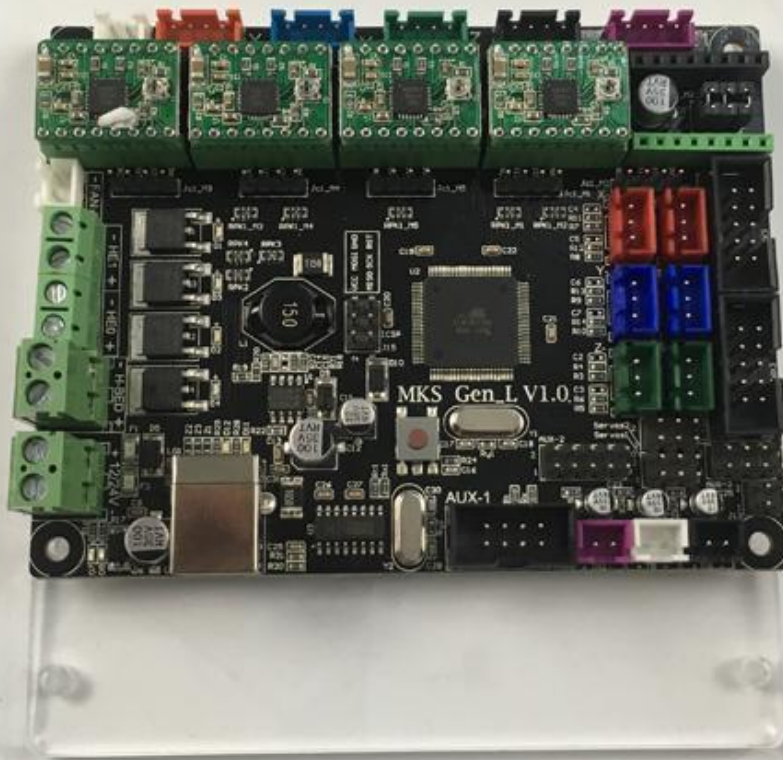

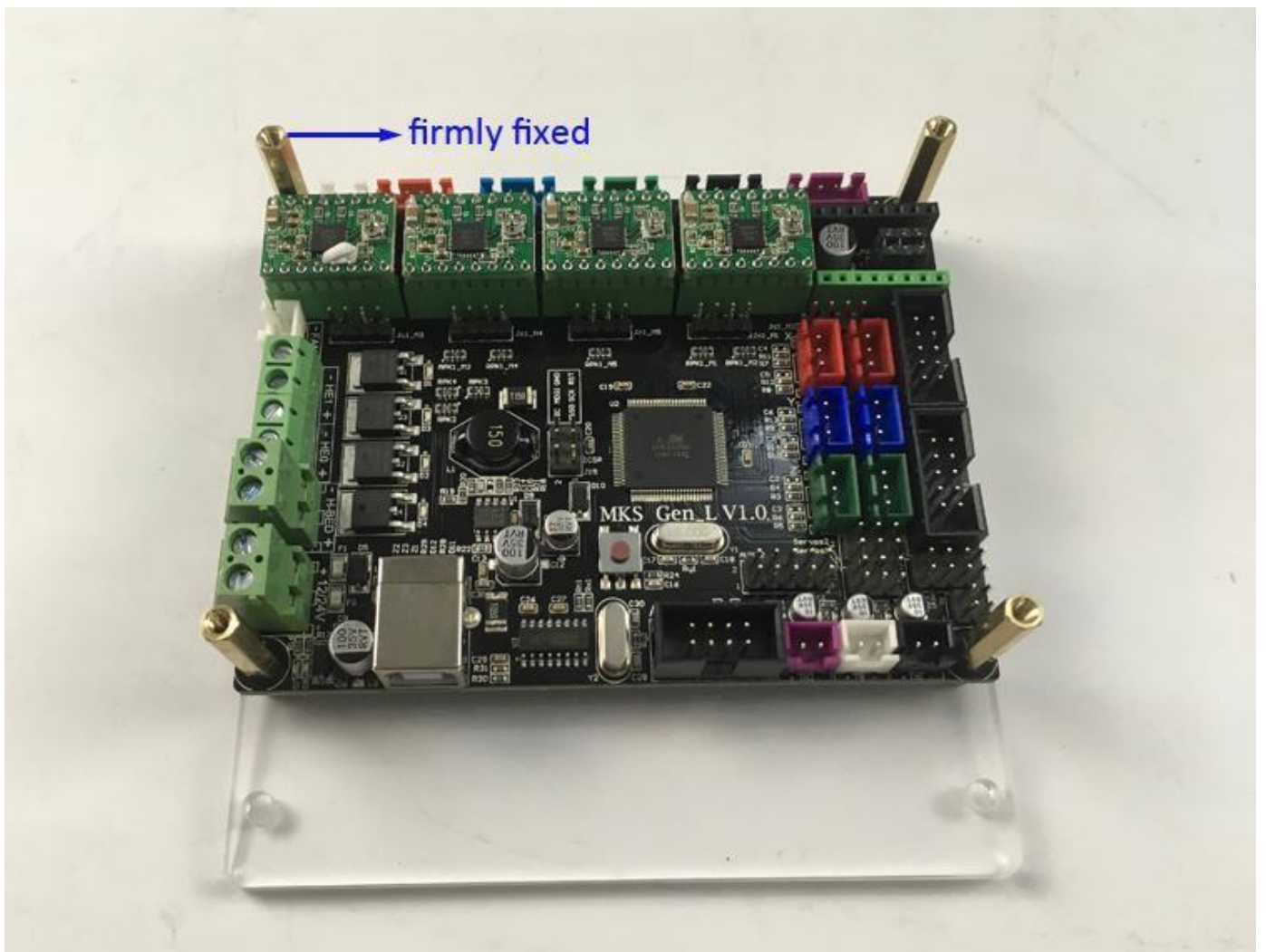
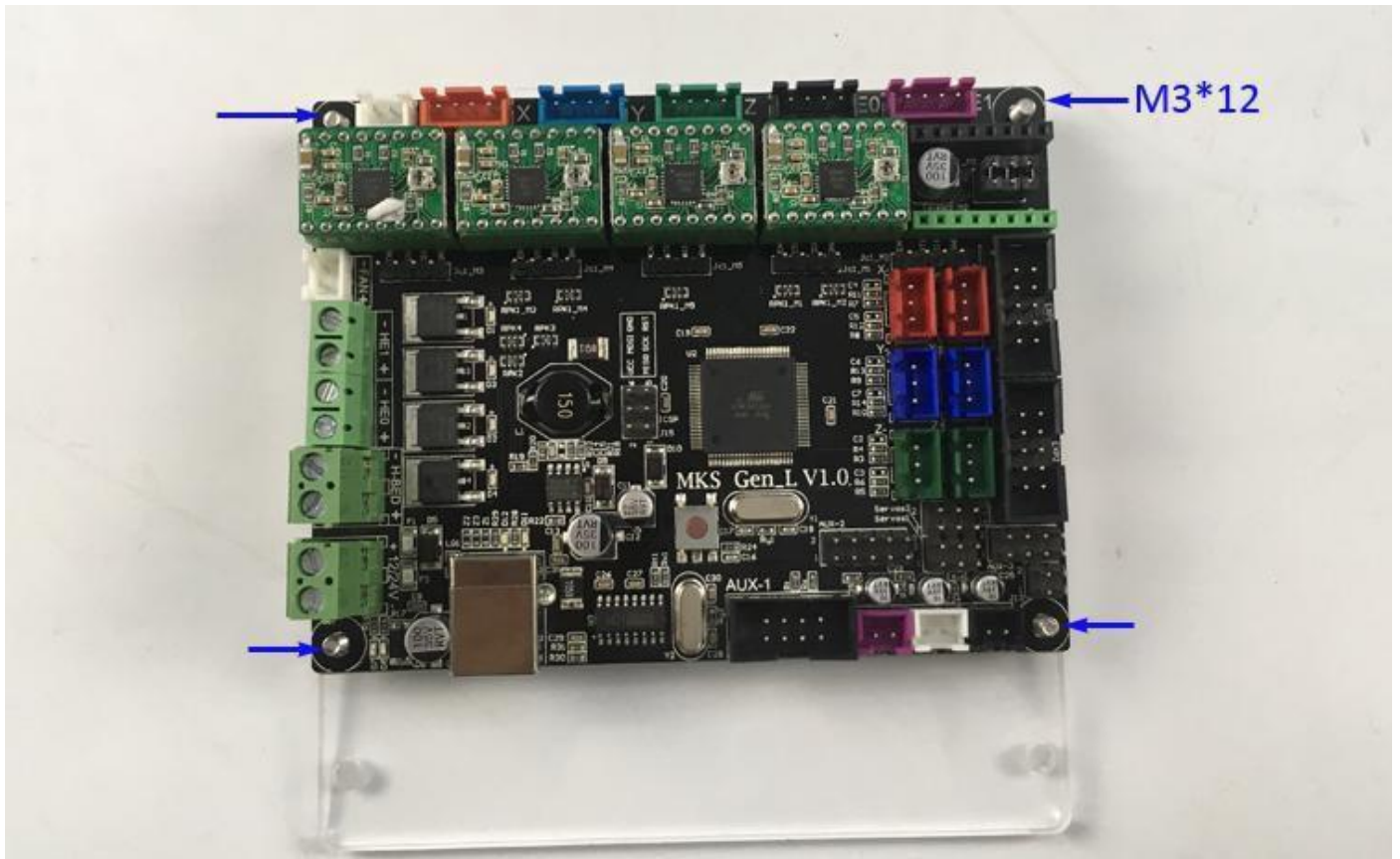

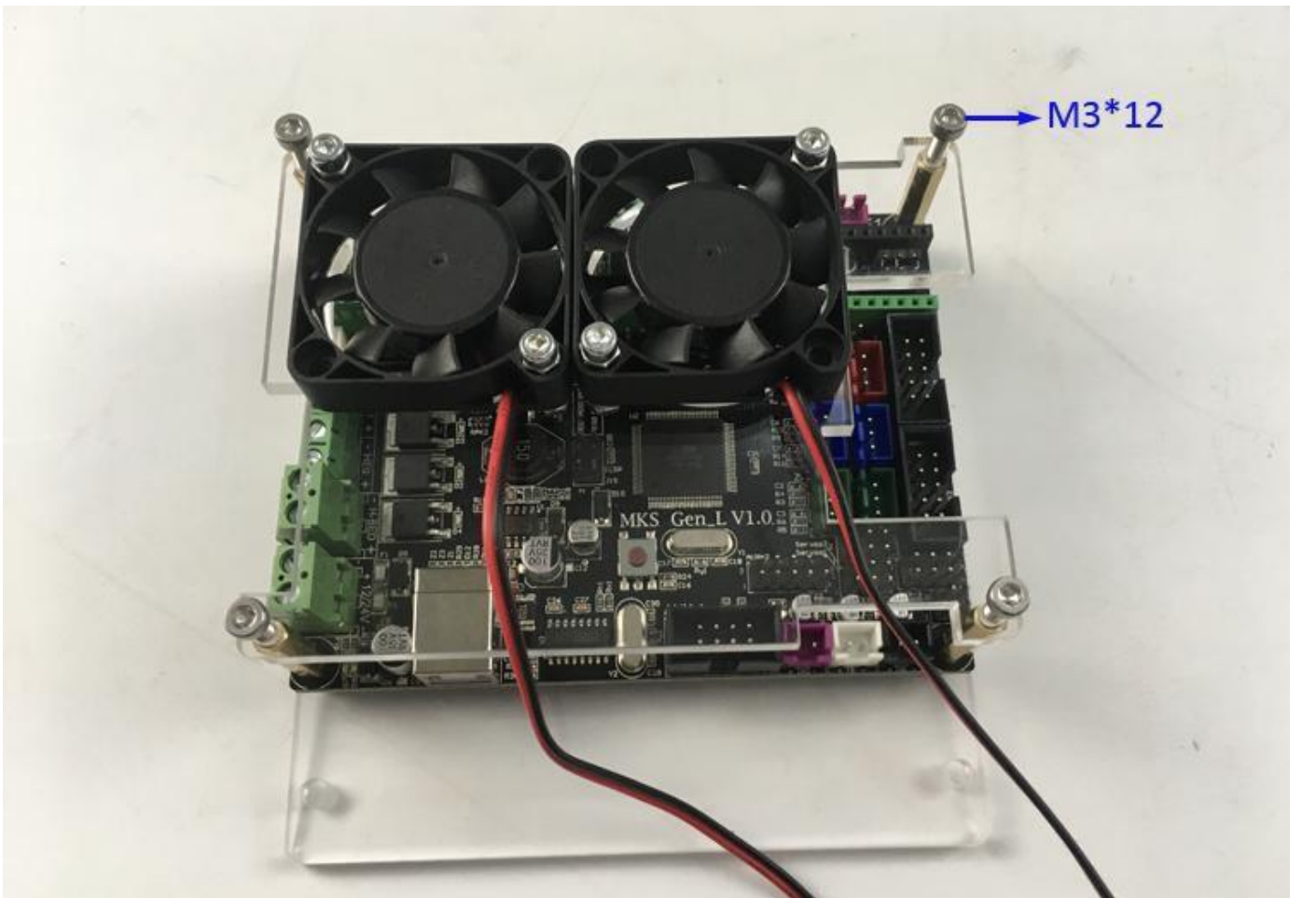
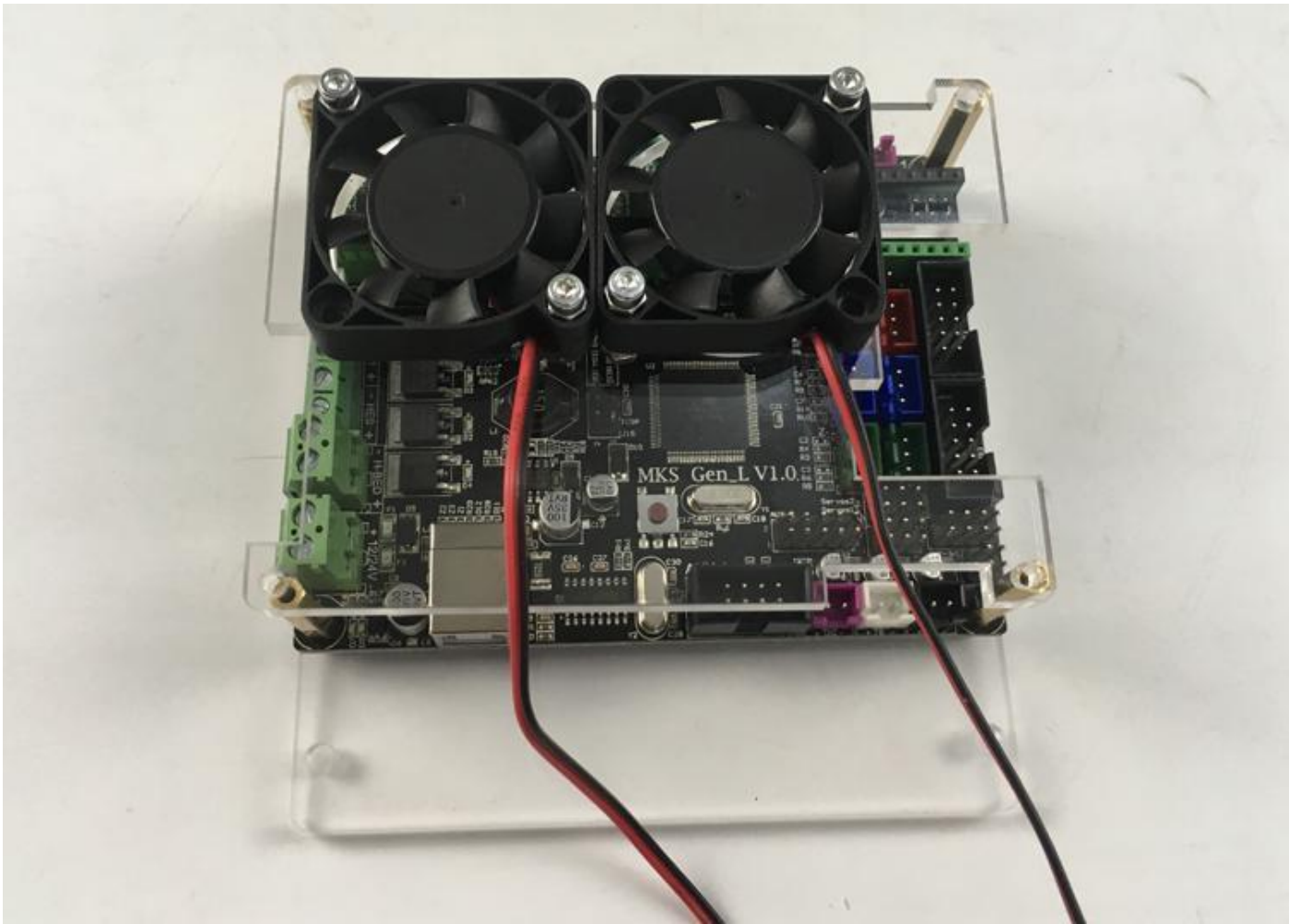

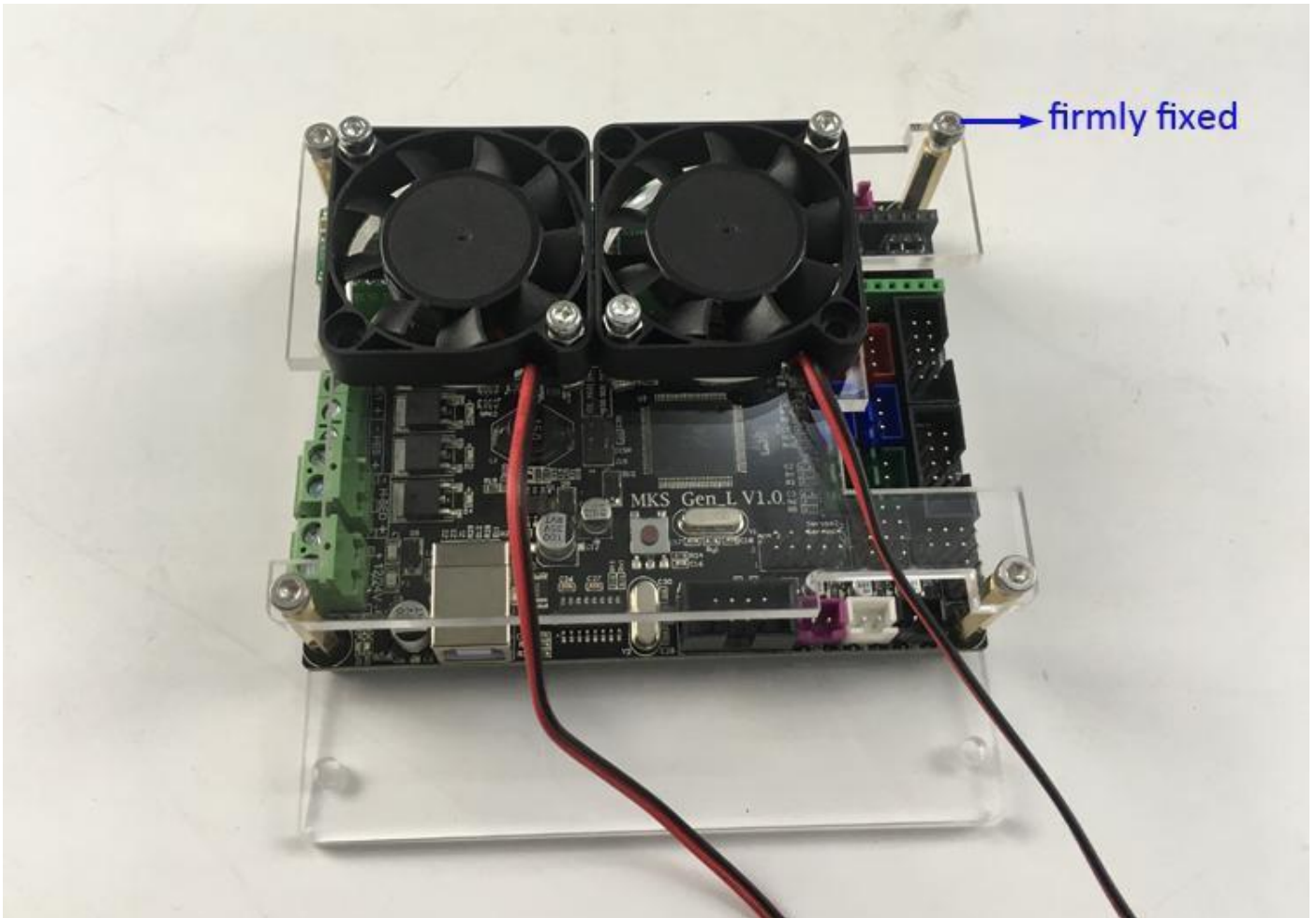

these are two lines from board fan  
conect to power directly  
need deal with like this



cut them by scissors

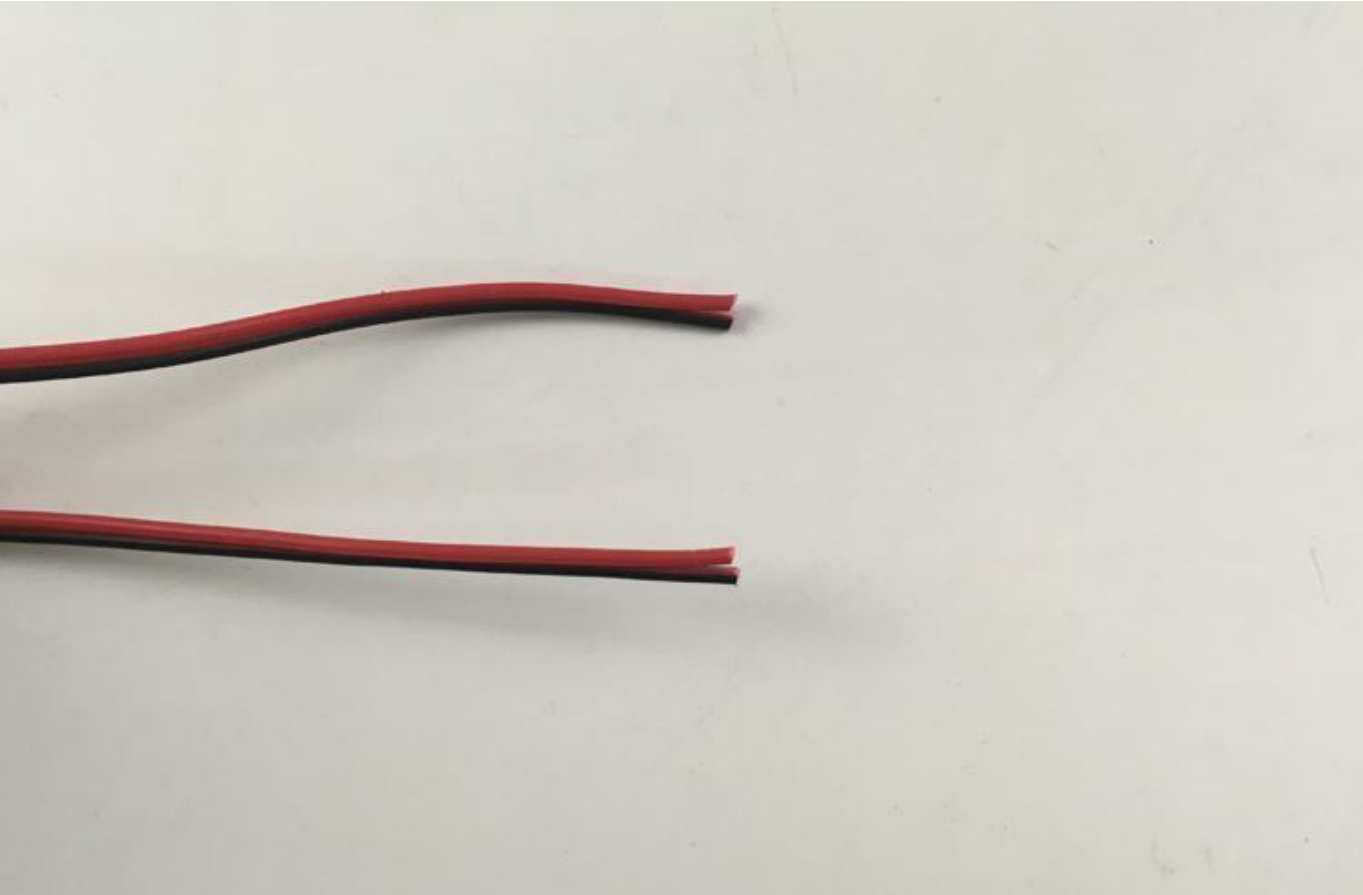



remove the skin of the line



this connect to power "+"



this connect to power "-"



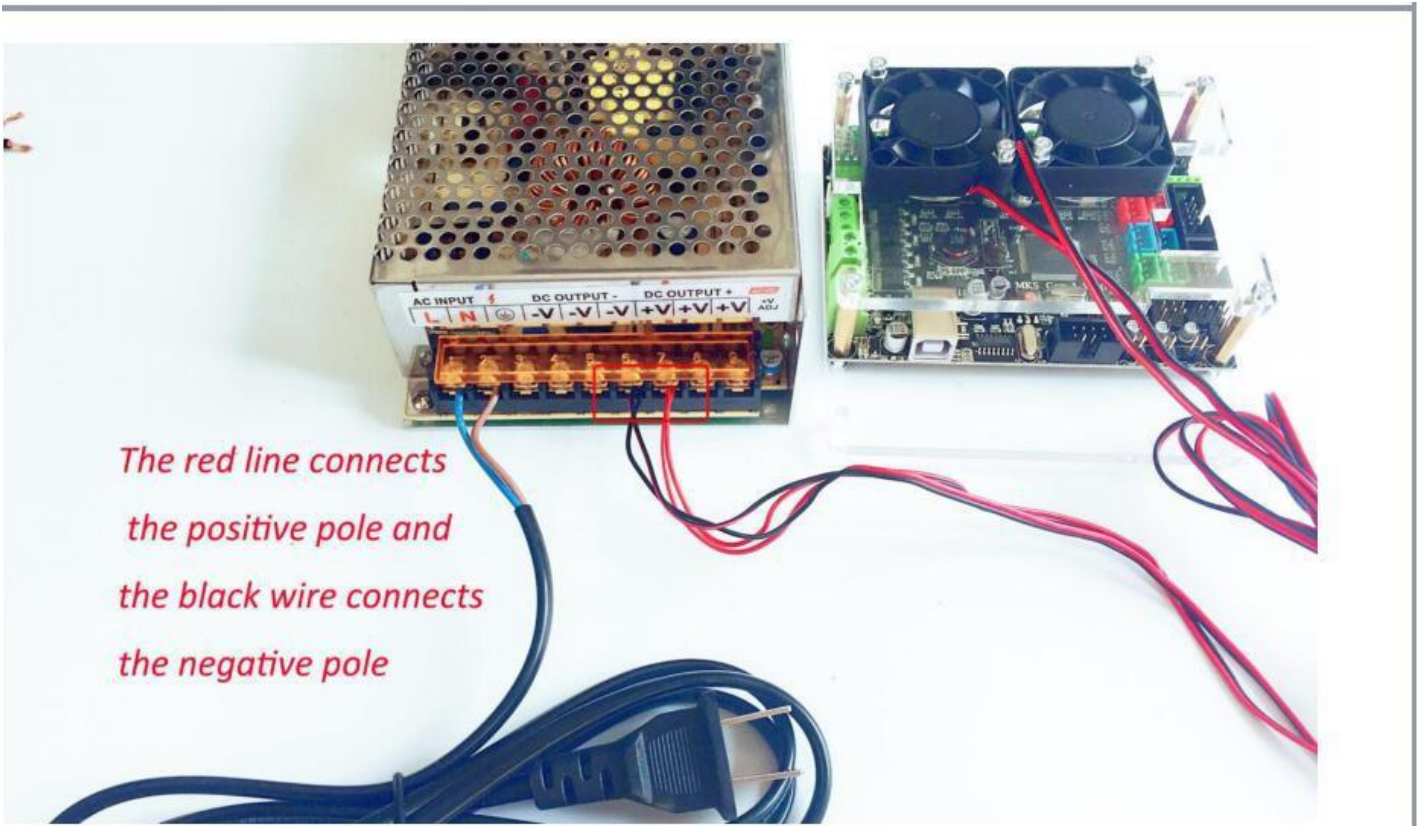

where to put the board ?  
there are many places can put boar,  
here provide two places,as reference.  
you can put where you like.

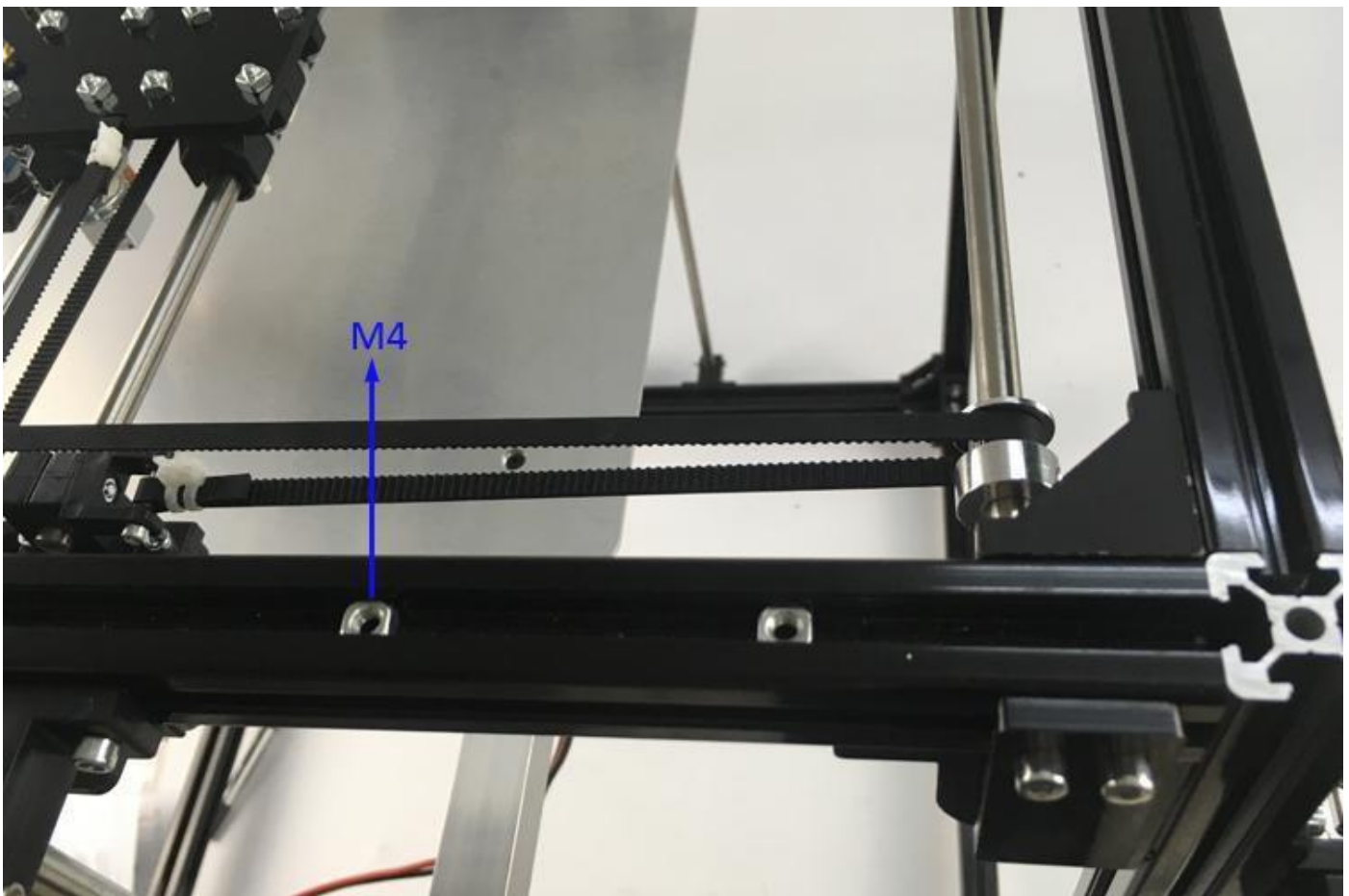
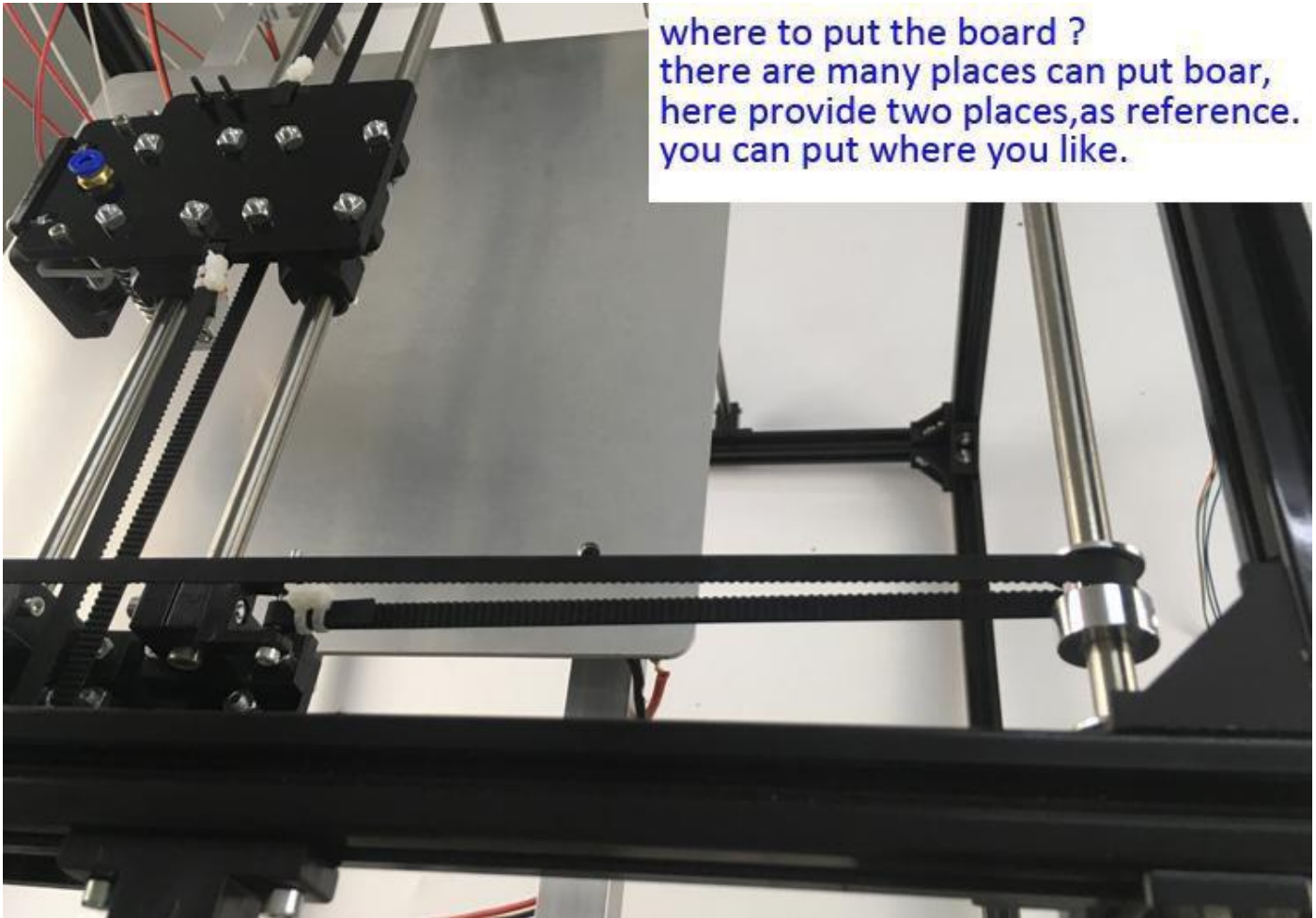

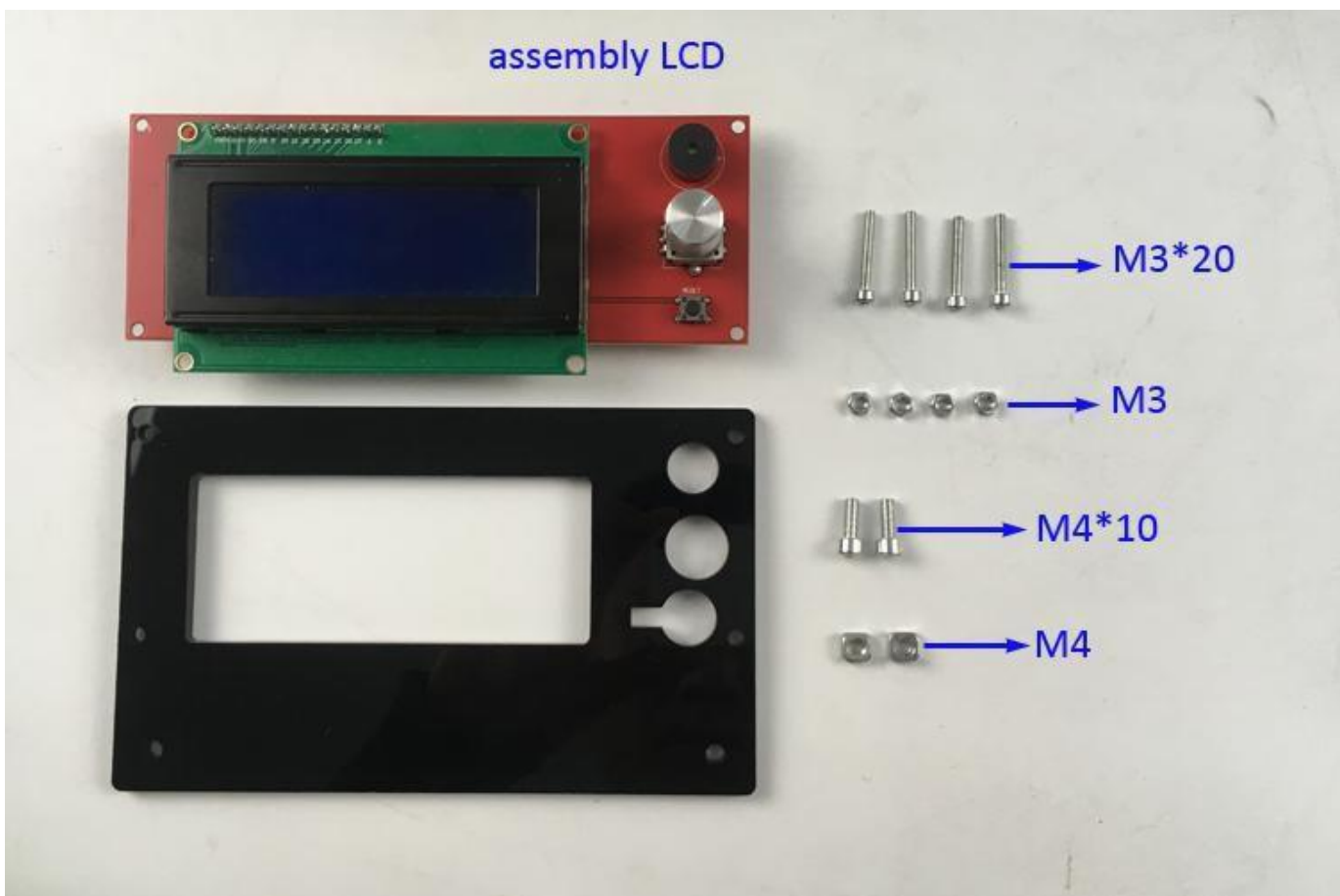
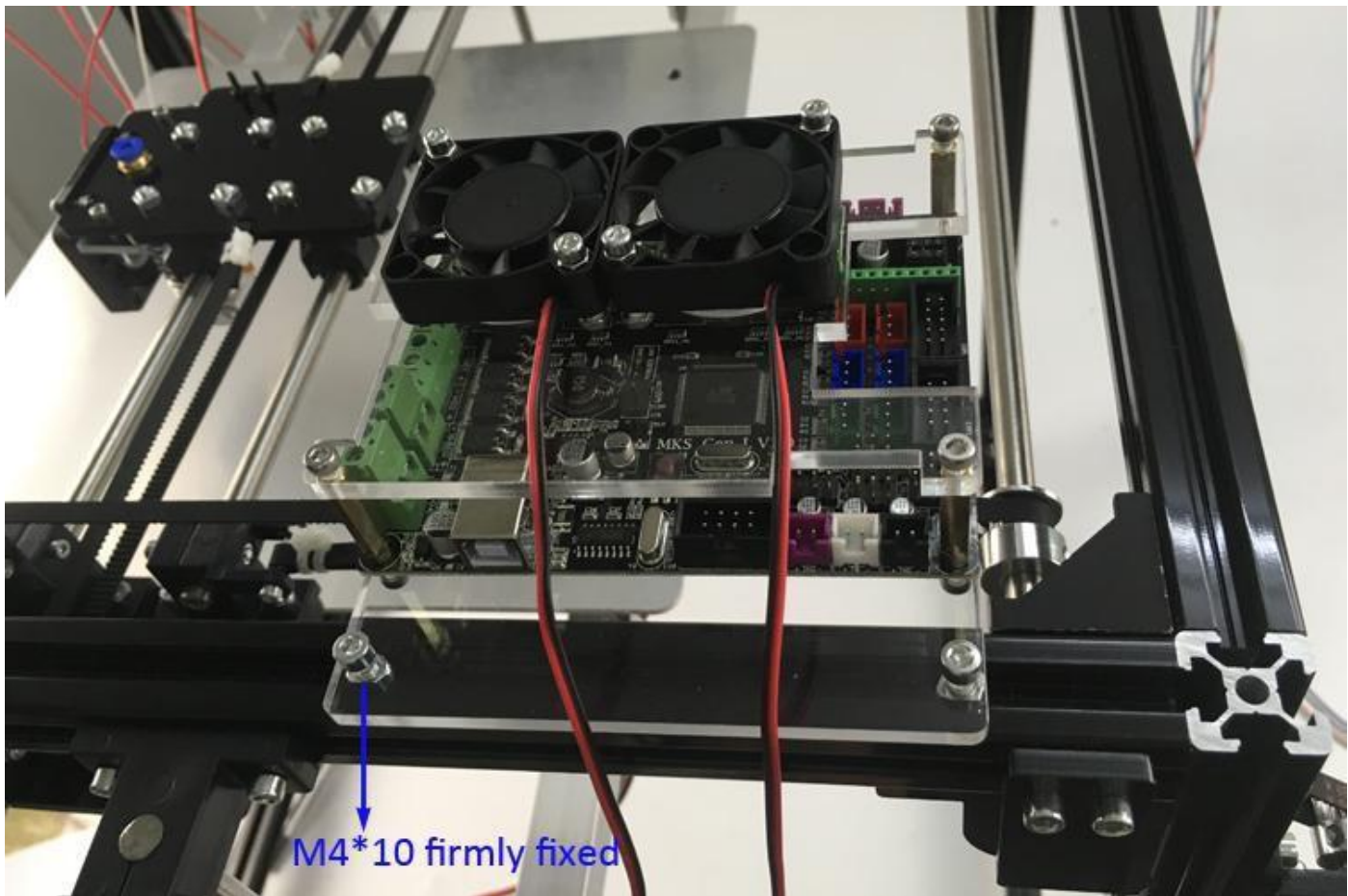

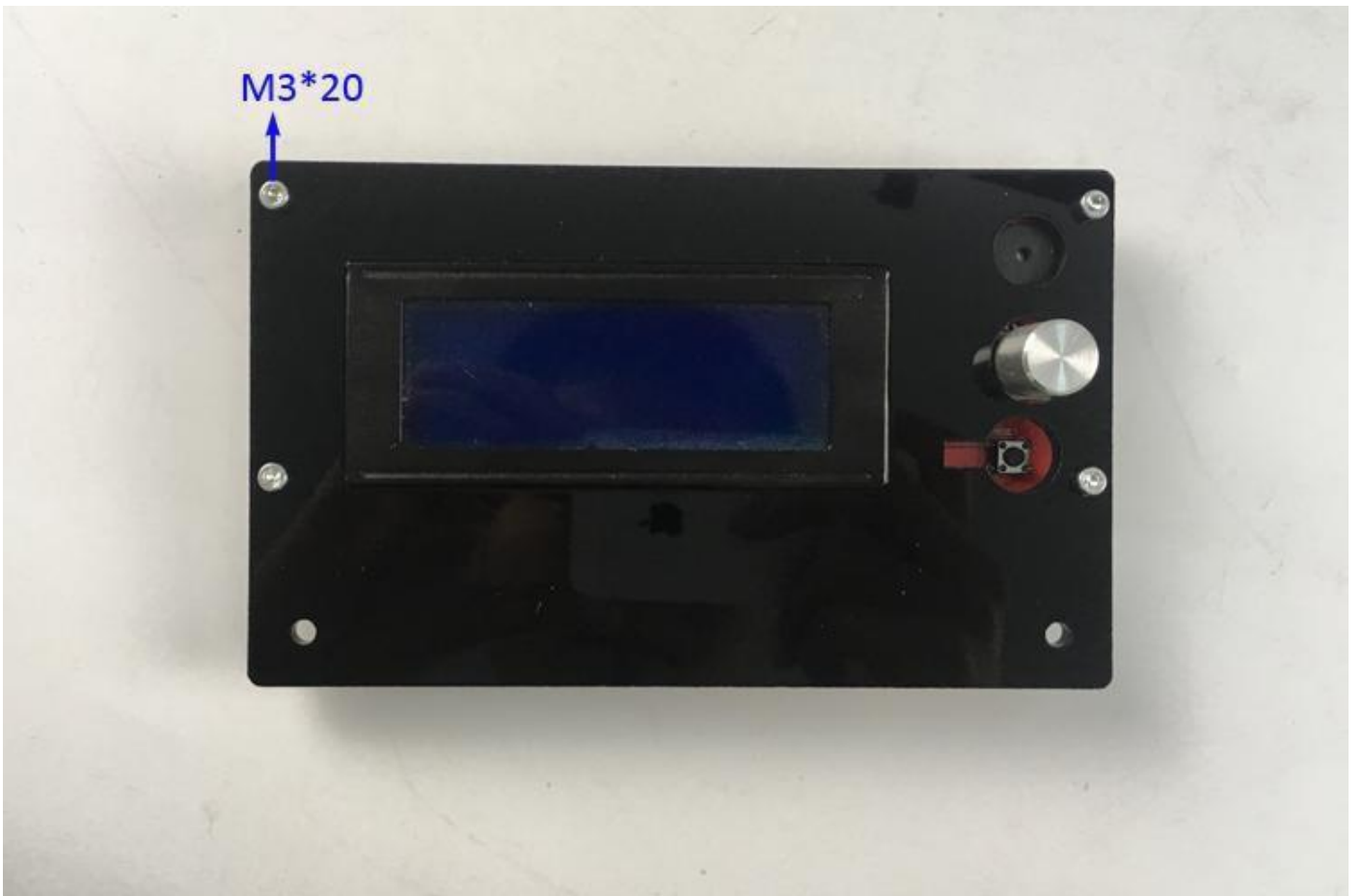
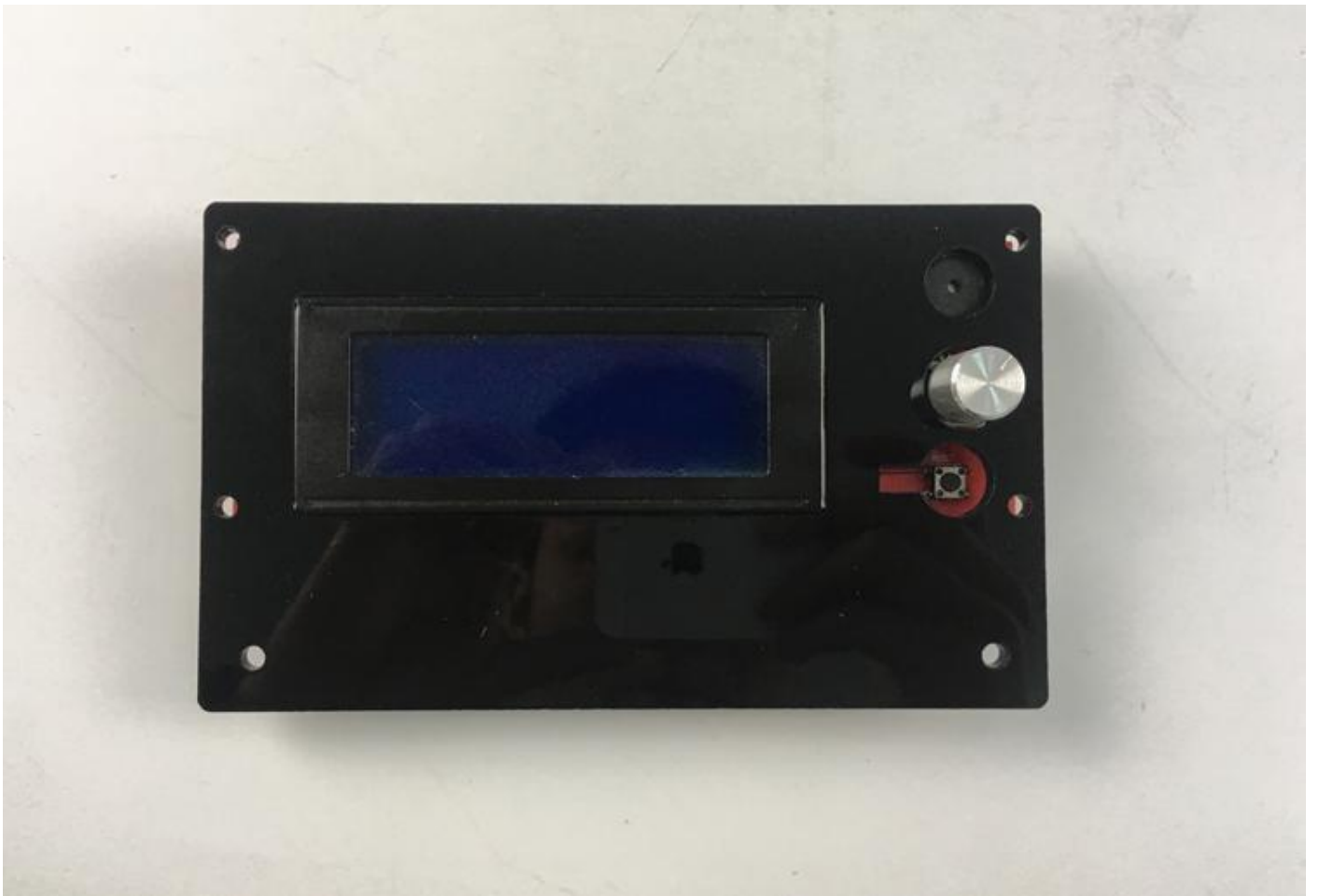

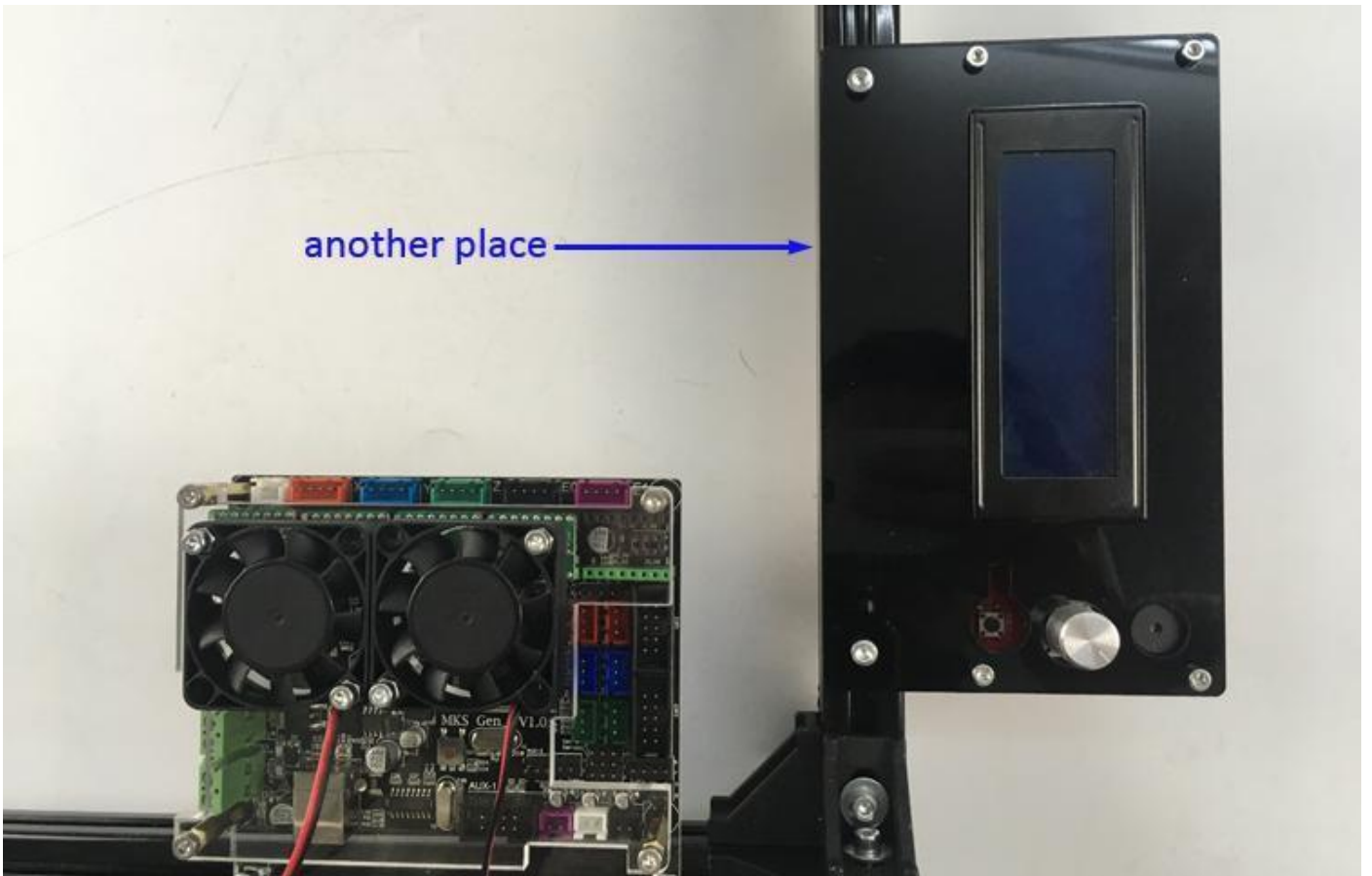
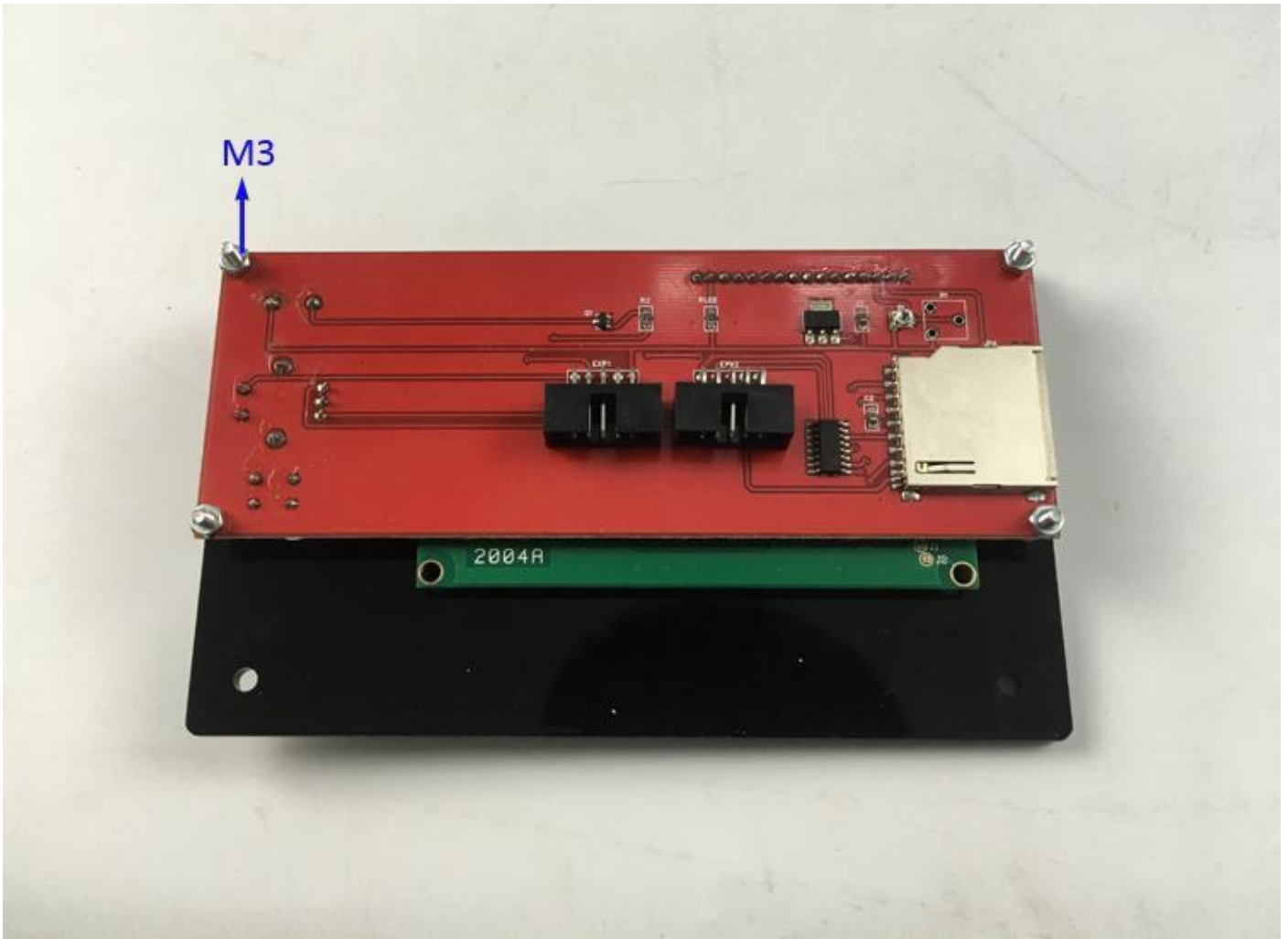

# If you are equipped with a touch screen

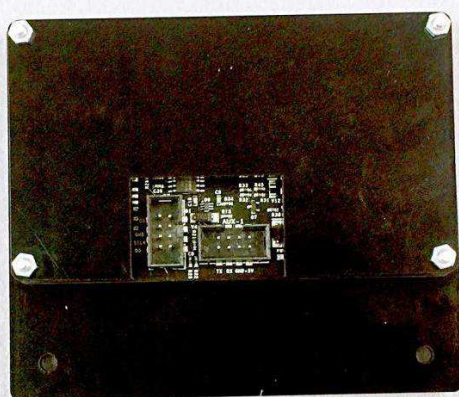
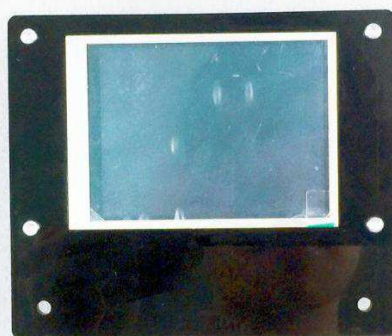
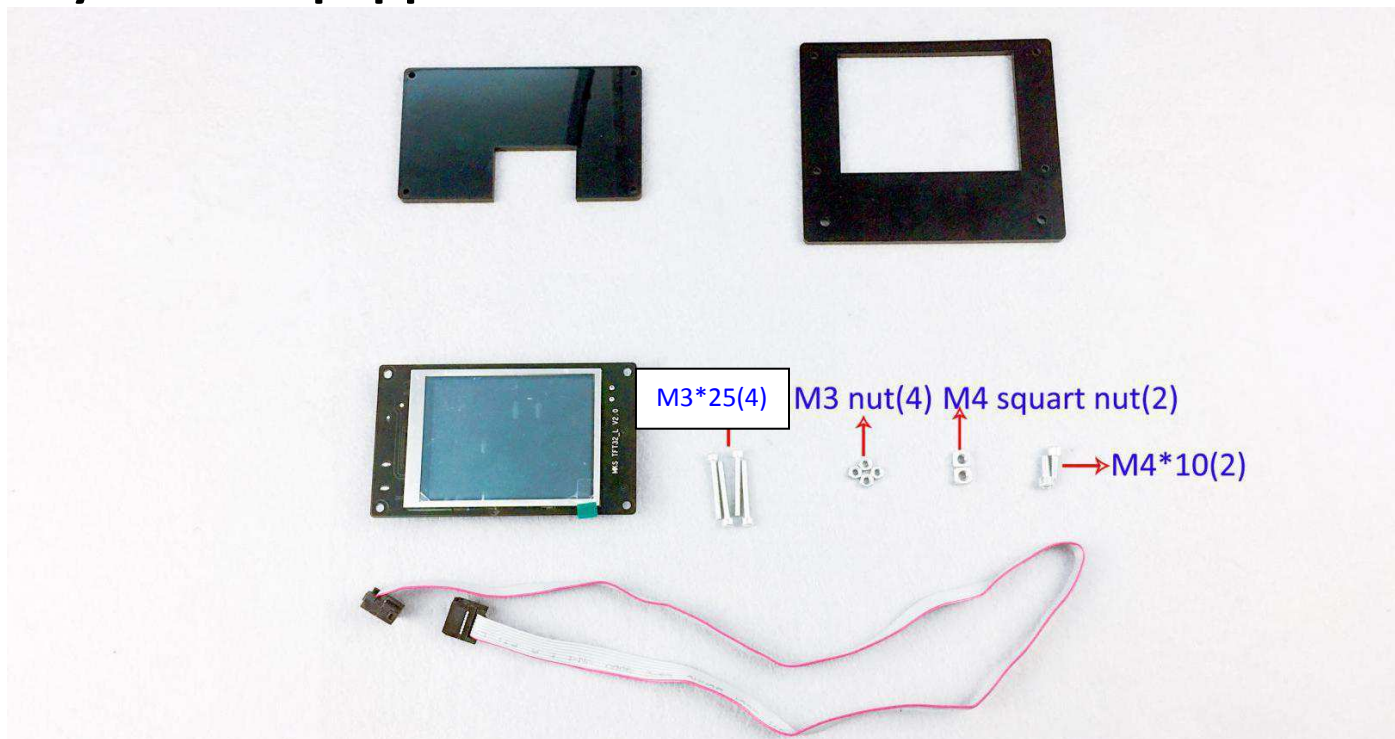

Firmly fix all the nuts

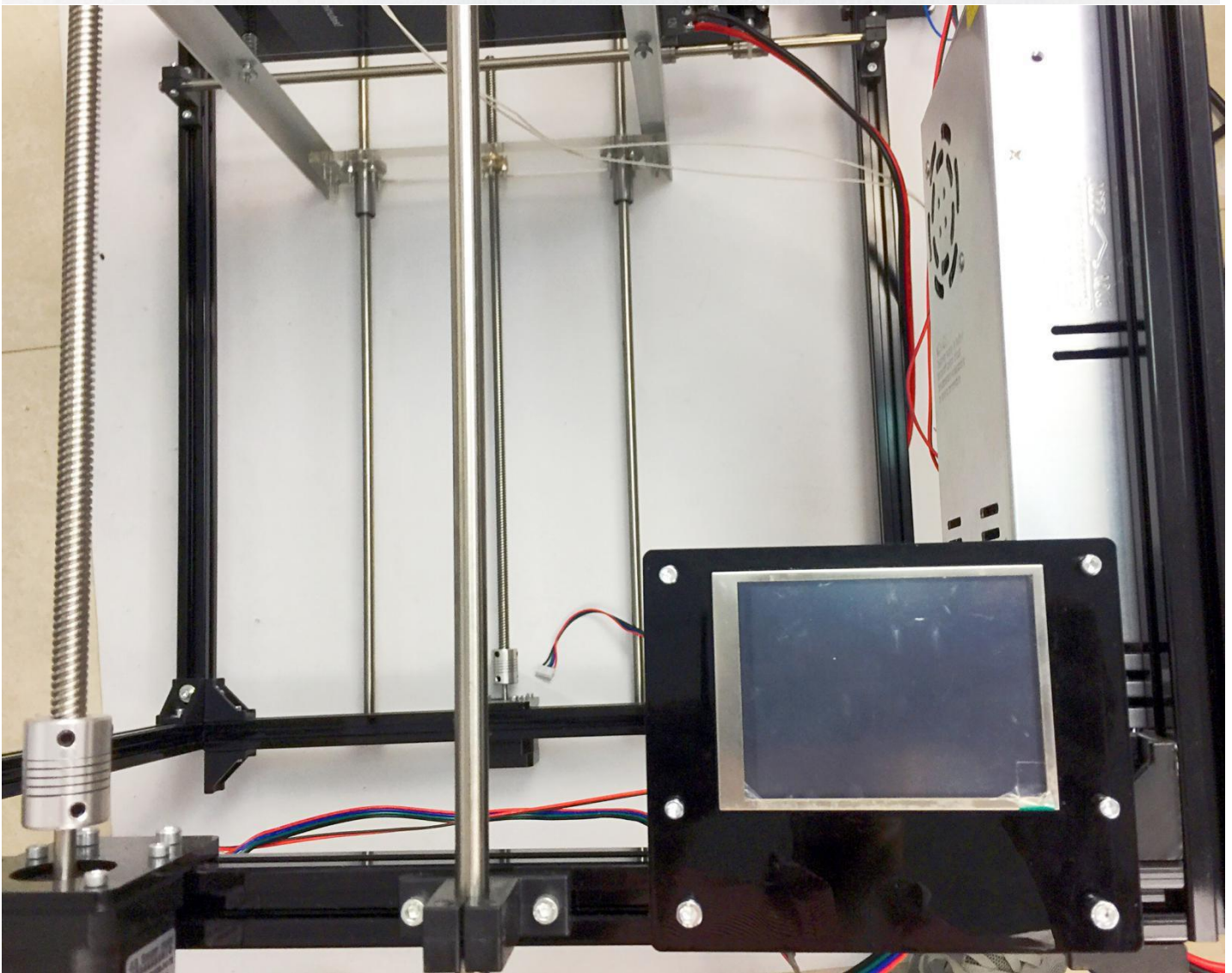
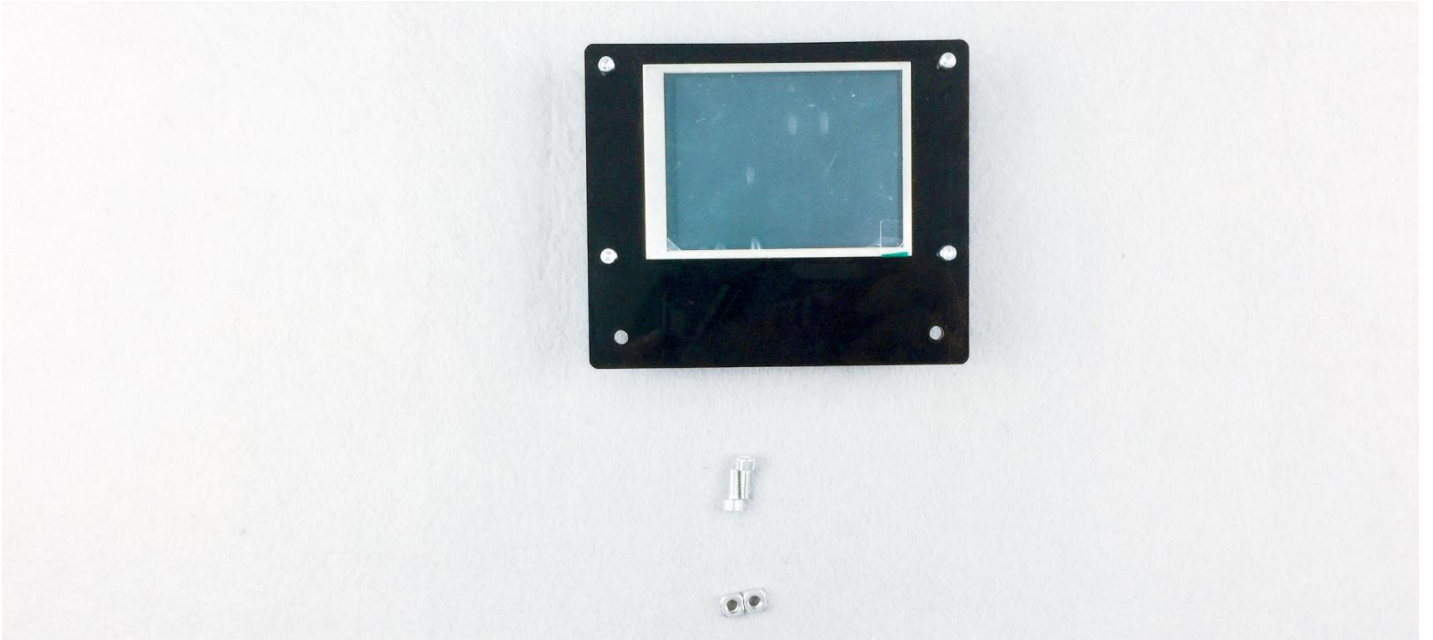

**You can install it in any suitable place.(In the case where the length of the cable is allowed)**



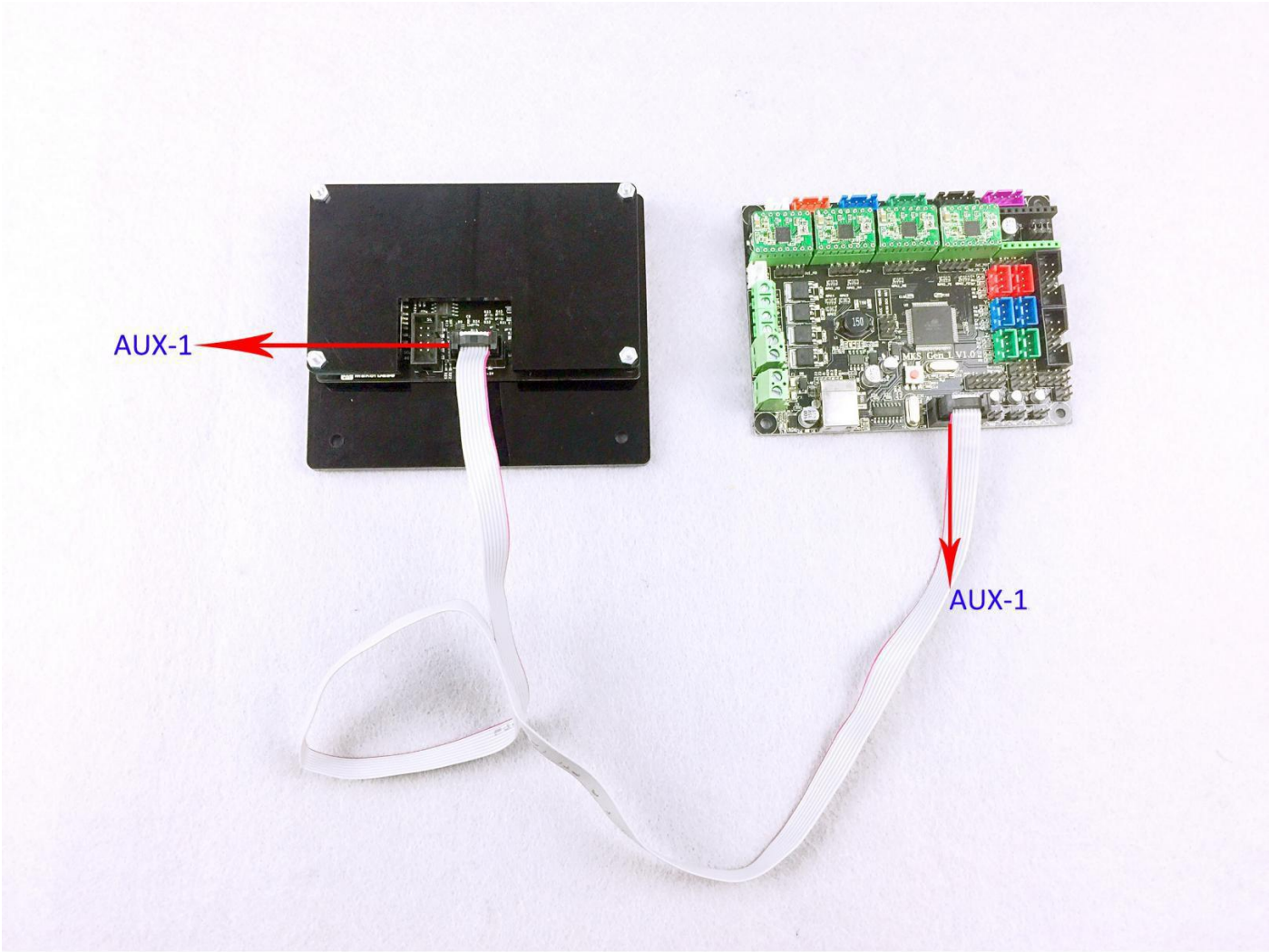



important note:if you use 110V voltage,pls adjust to 110 V  
if you use 220V voltage,pls adjust to 220V



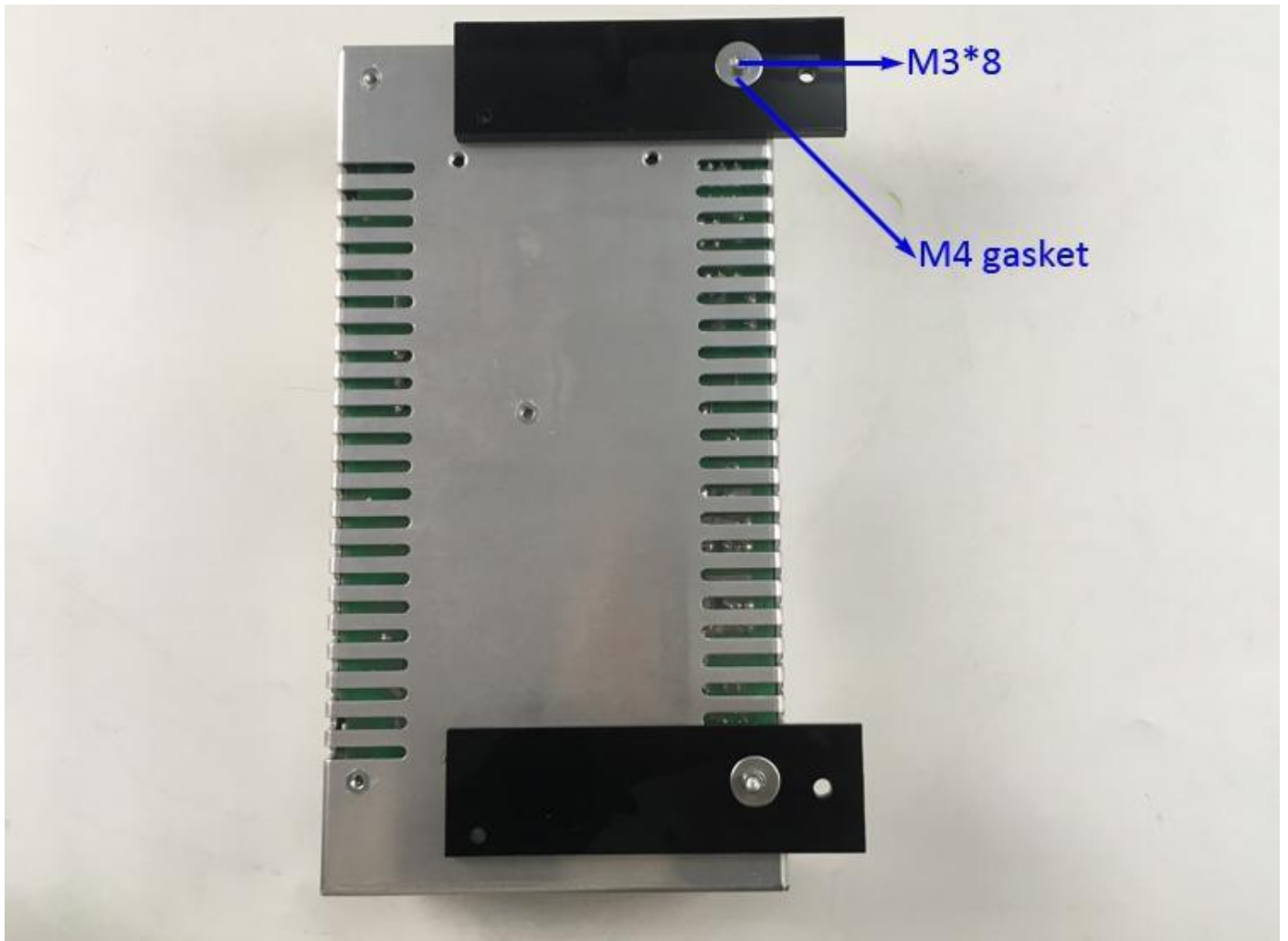

when use power, the safe is the most important!!!  
dont connect AC(110V or 220 V) to board directly.  
it's right connect the board to power,  
connect the board must be 12V.

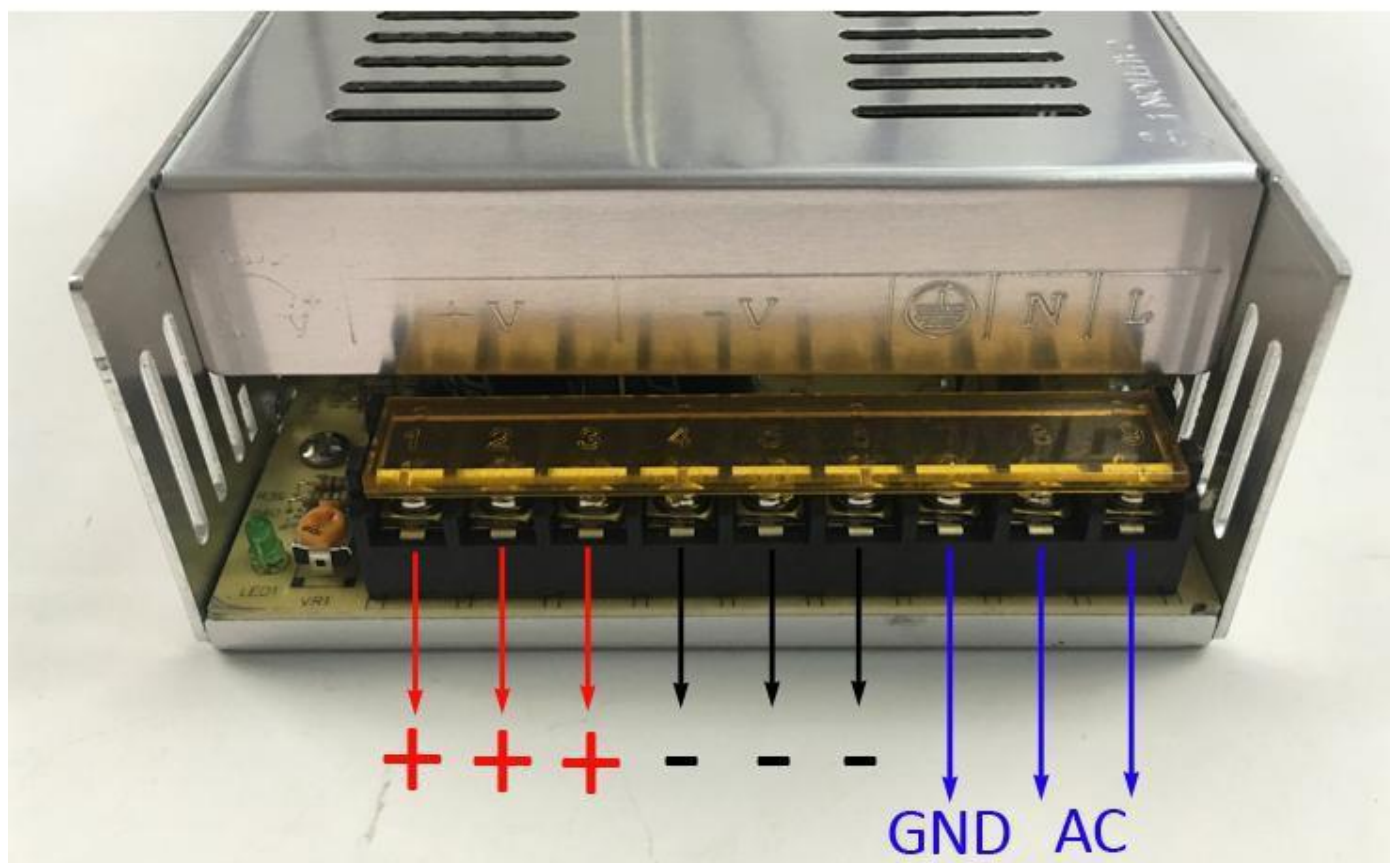

1 2 3 → +

4 5 6 → -

7 → GND

8 9 → AC

## 7 Connect cable

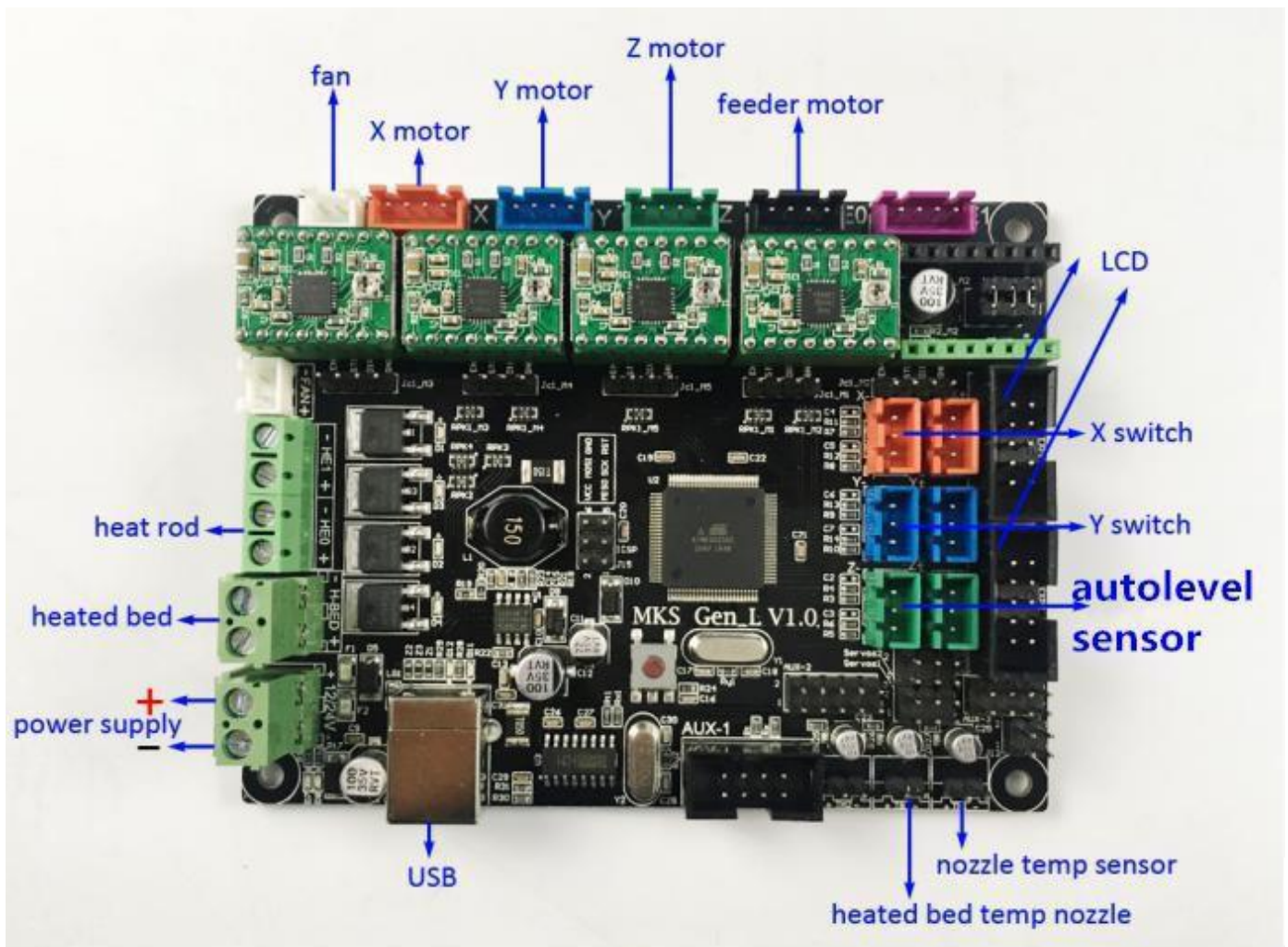

- 1,prohibit connect the AC (110V or 220V) to board directly,it's very dangerous. the board should connect to switch power (12V output).
- 2,the board connect to switch power, "+" must connect to switch power "+", "-" must connect to to "-". this must connect be right,if not,the board will be damaged.
- 3,the fan must be always working,the fan cool the hotend,if not work,will block the nozzle, can not print.
- 4,two temp sensors(nozzle temp sensor and heated bed temp sensor) must connect well,the printer can work.
- 5,for LCD,must exp1 connect to exp1, exp2 connect to exp2.
- 6,for heated bed,can connect to board,also can connect to power directly.
- 7,heat rod,heated bed,temp sensor dont distinguish"+" and "-". power supply and fan must distinguish"+" and "-".

**If you are using a manual leveling, the installation of a Z-axis limit switch, you should disconnect the automatic sensor from the main board and insert the Z-axis limit switch occupy its jack.**

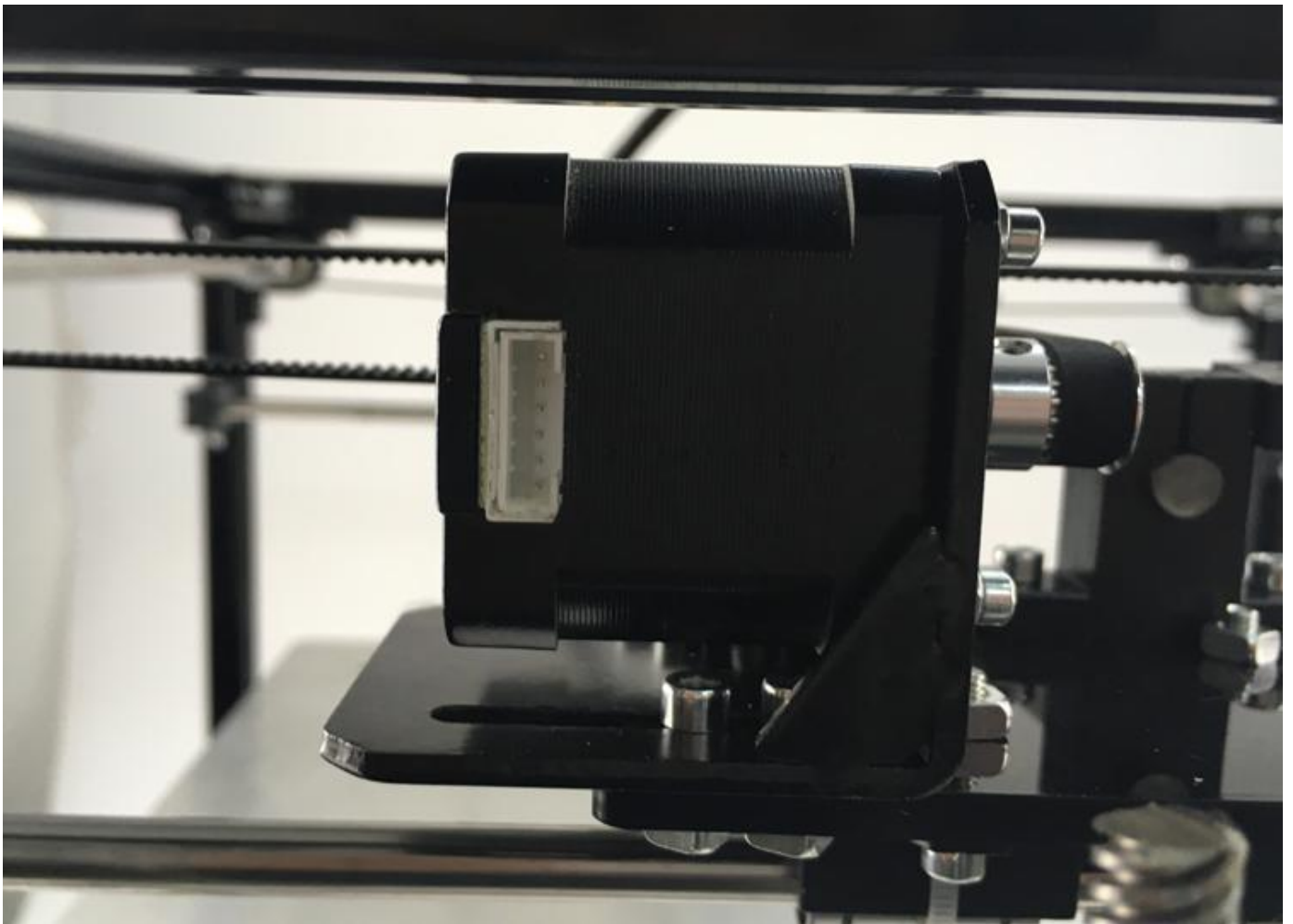
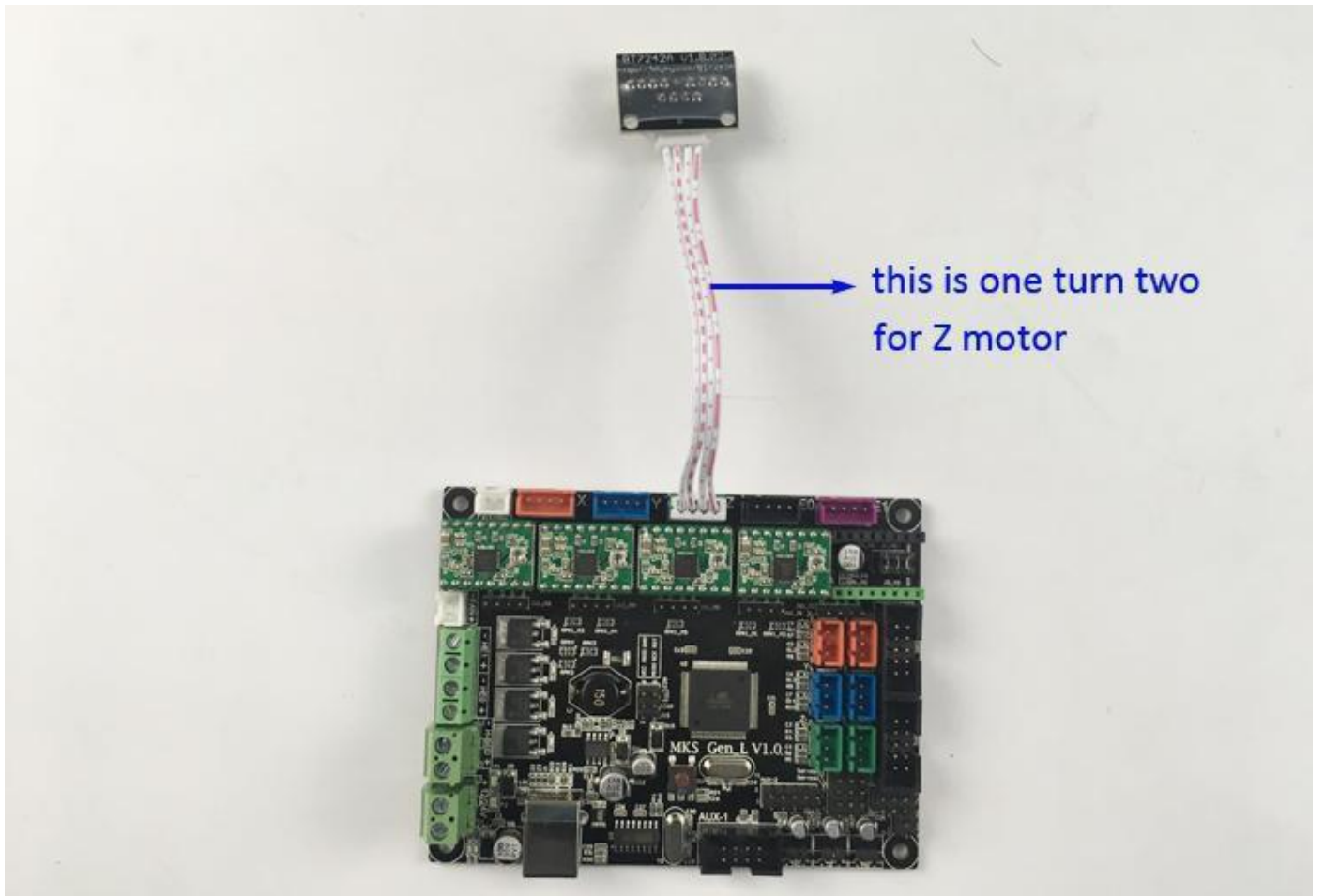

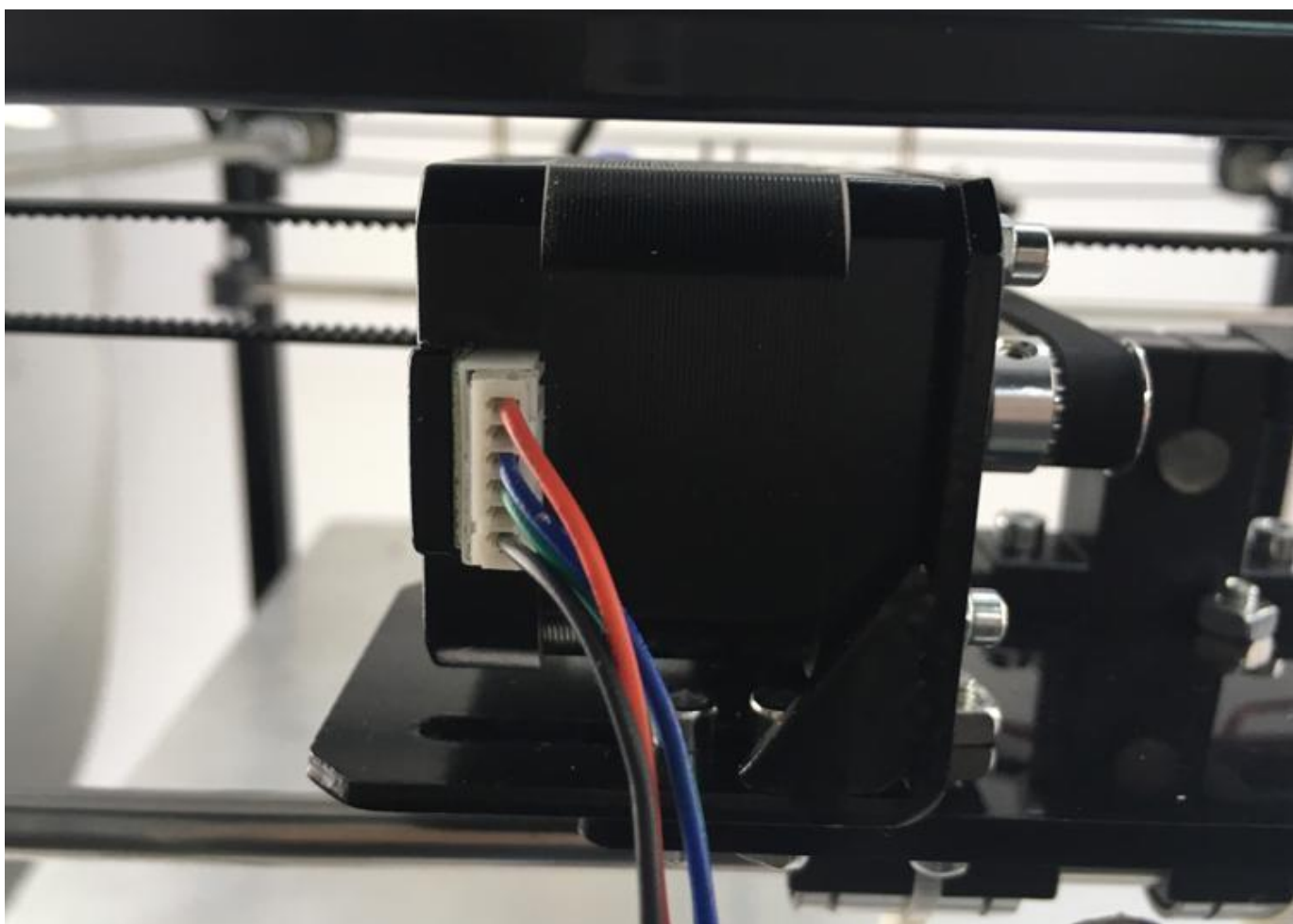

fan and motor connect  
Z motor use "one trun two"

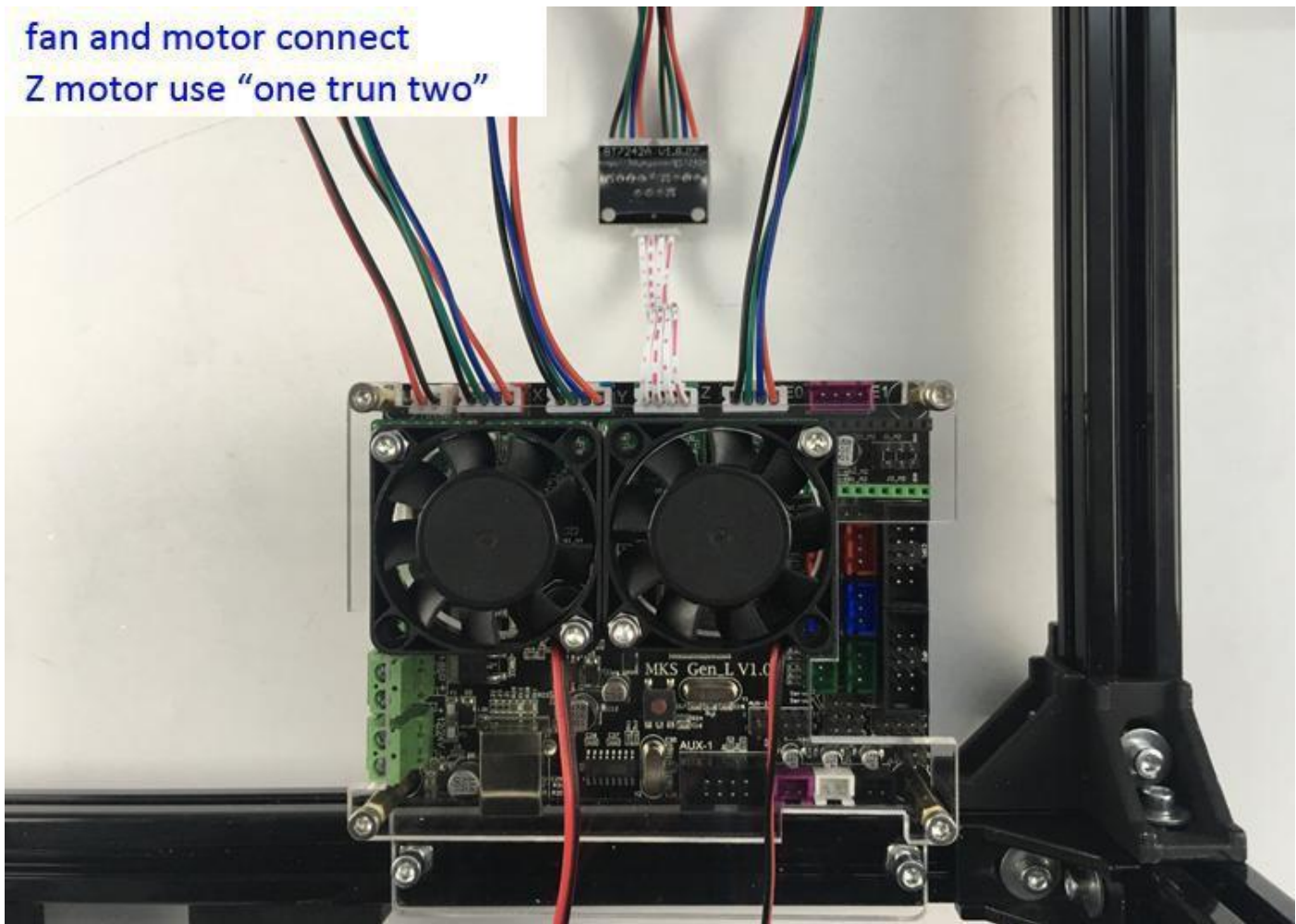

heat rod, heated bed and power supply connect

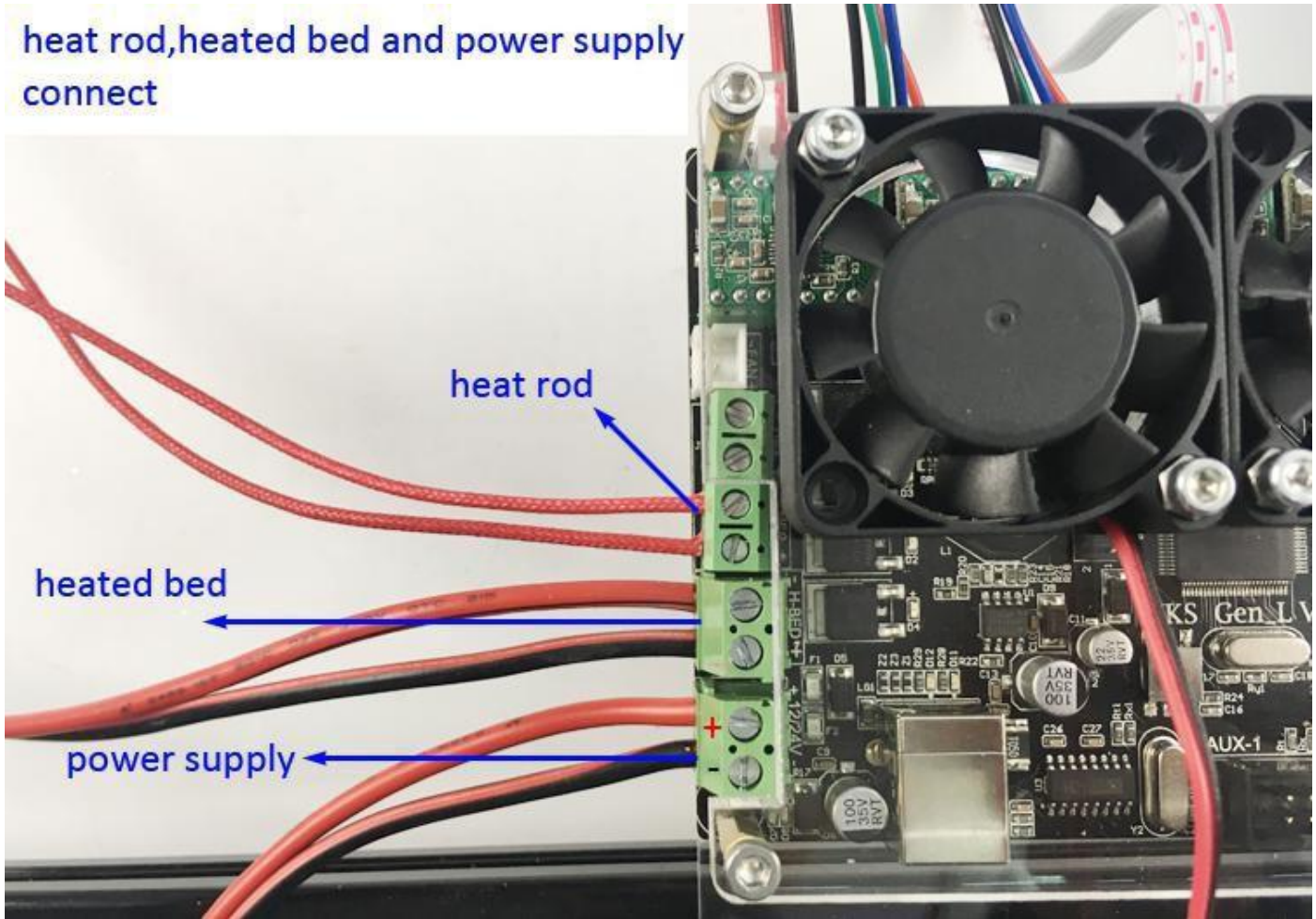



heat rod and heated bed temp sensor connect

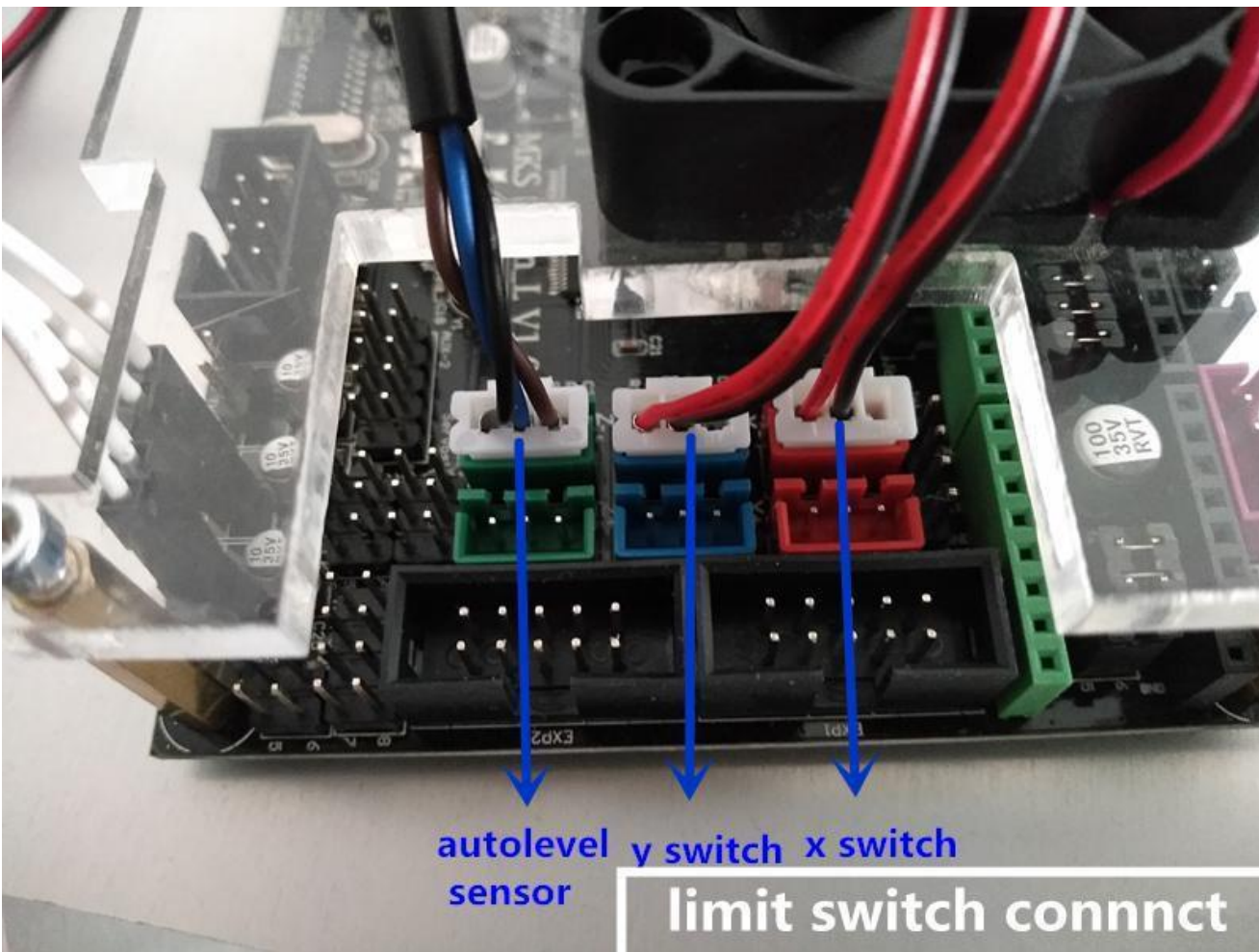
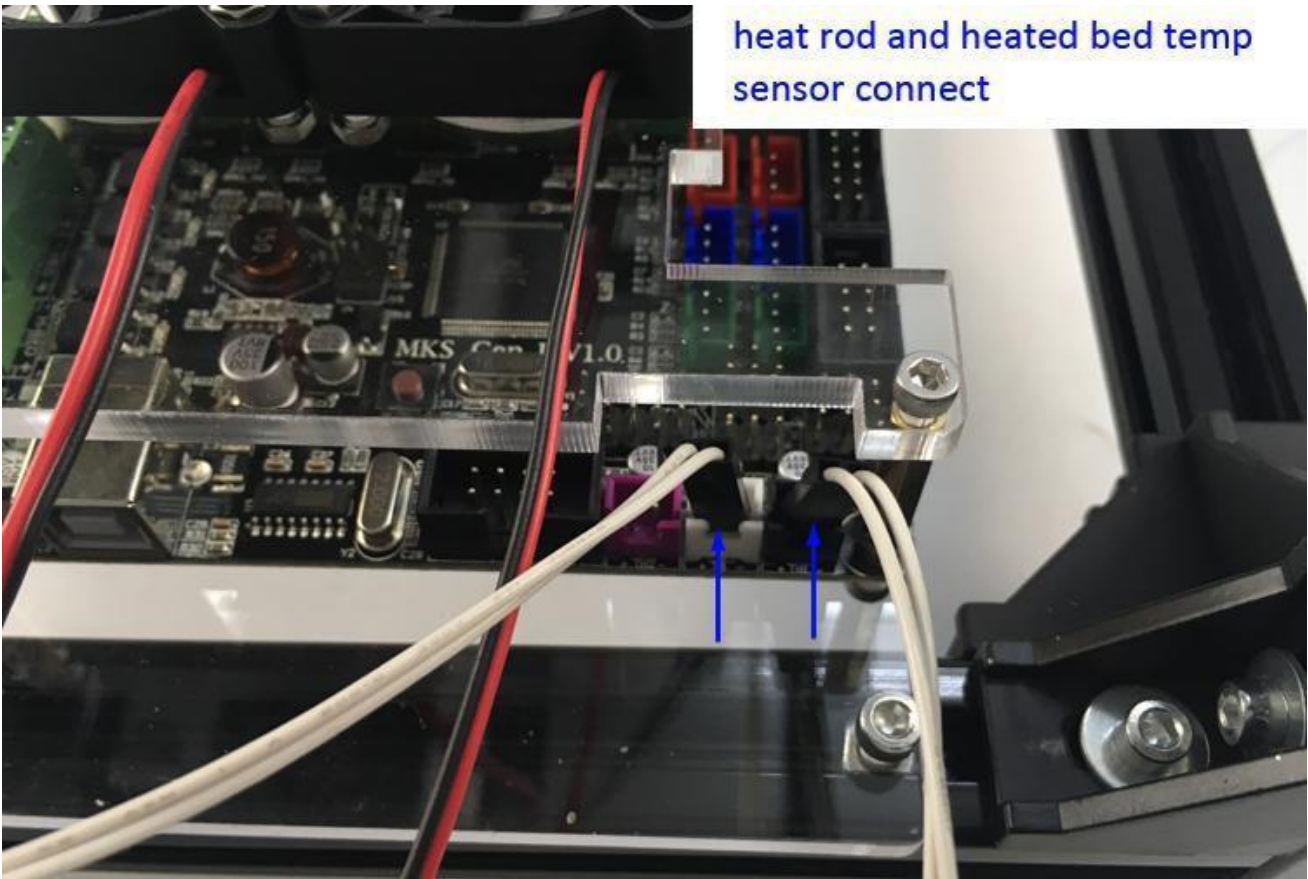

autolevel sensor y switch x switch

limit switch connnct

LCD connect  
exp1 connect to exp1  
exp2 connect to exp2

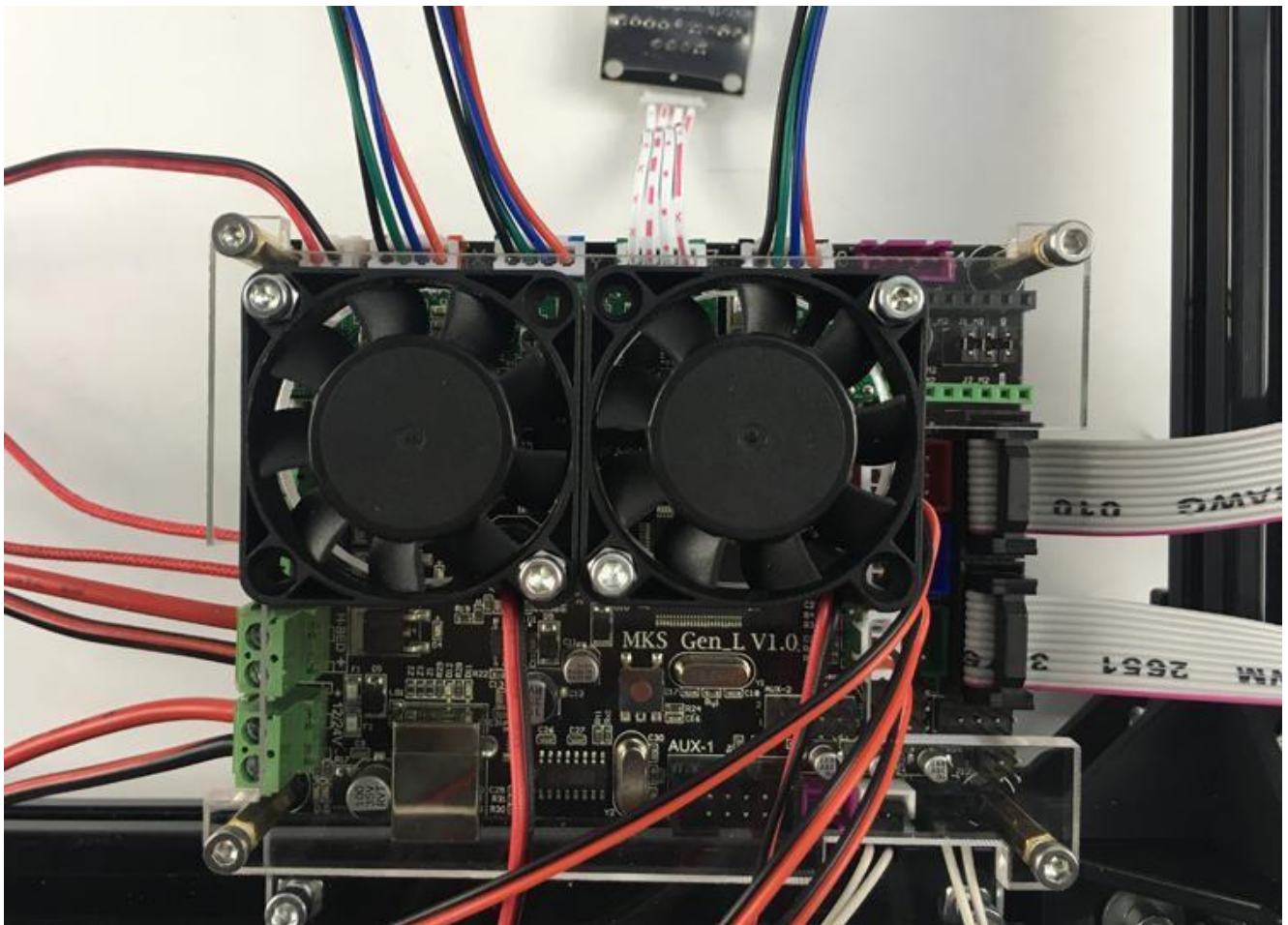
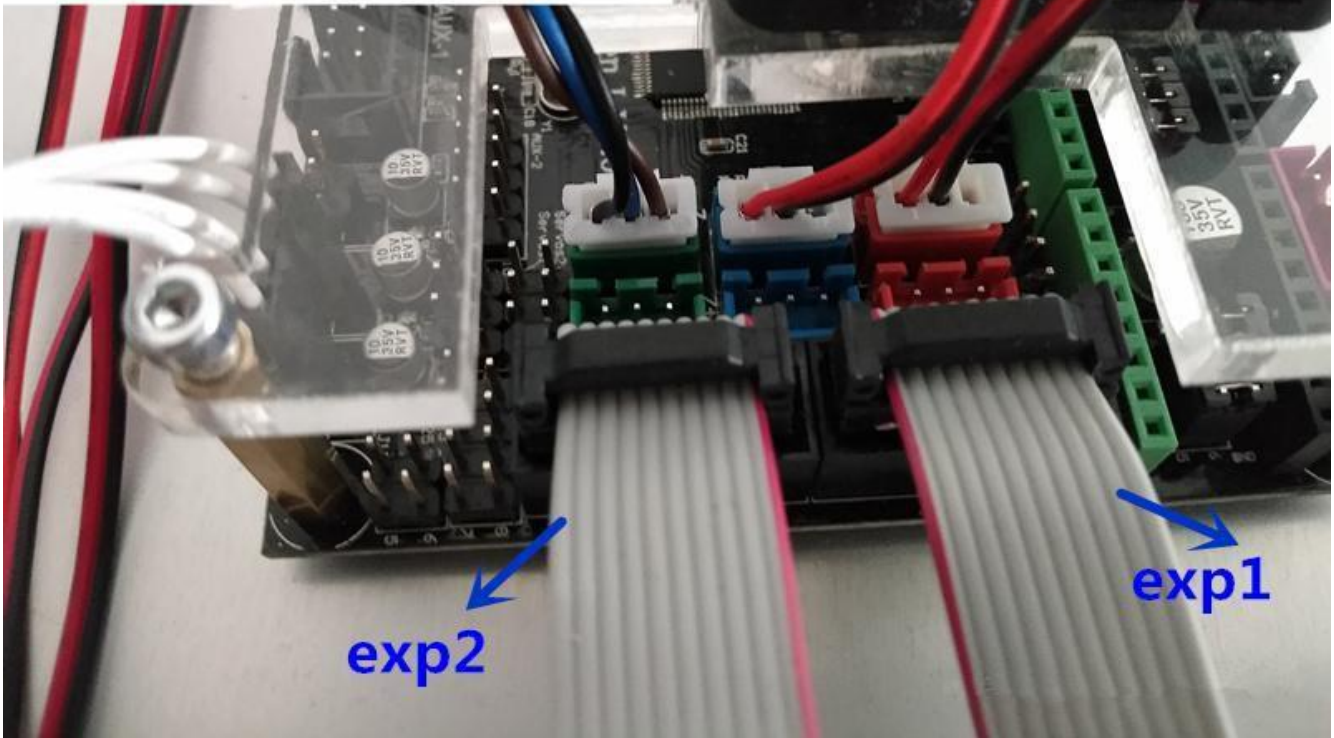

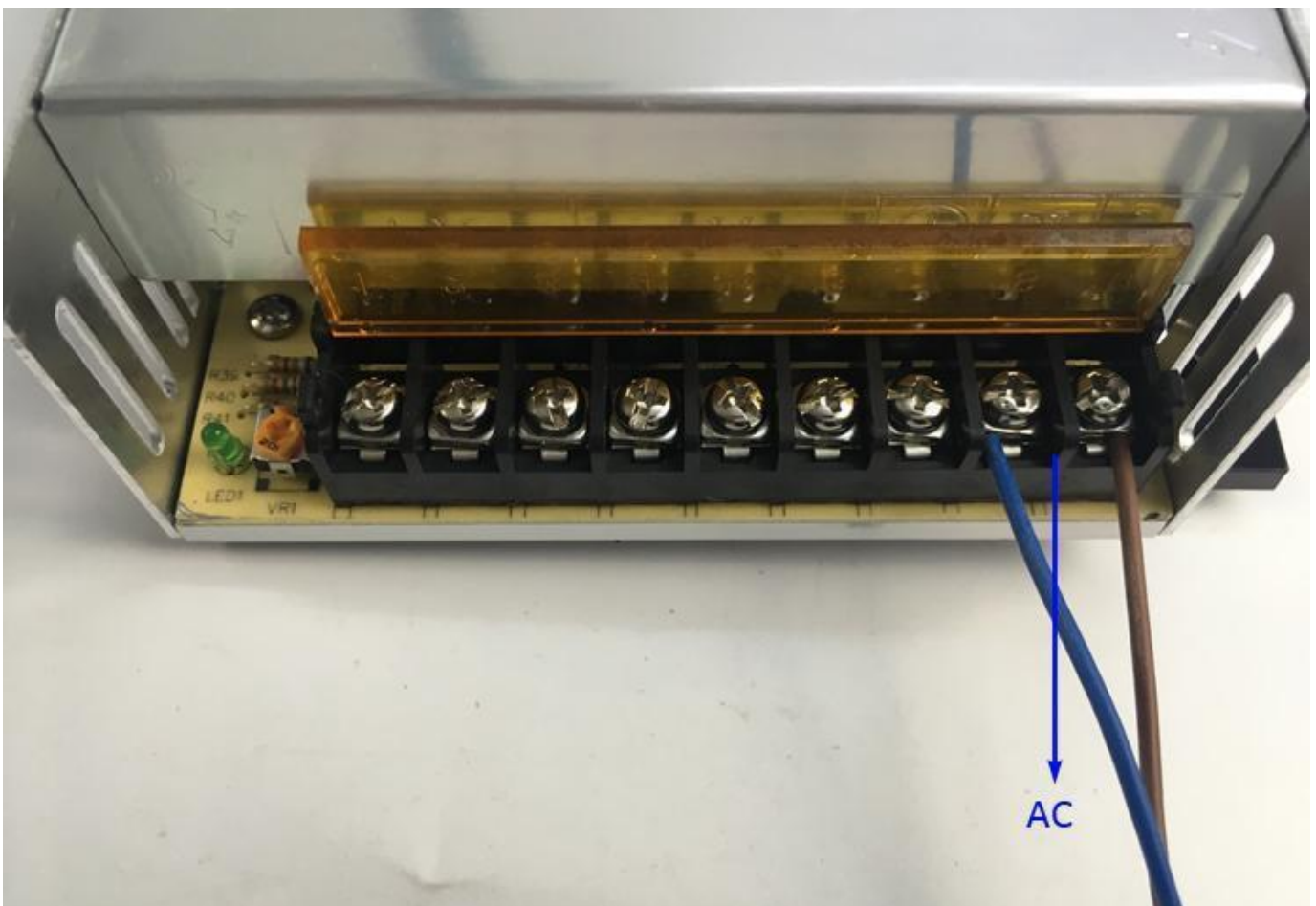
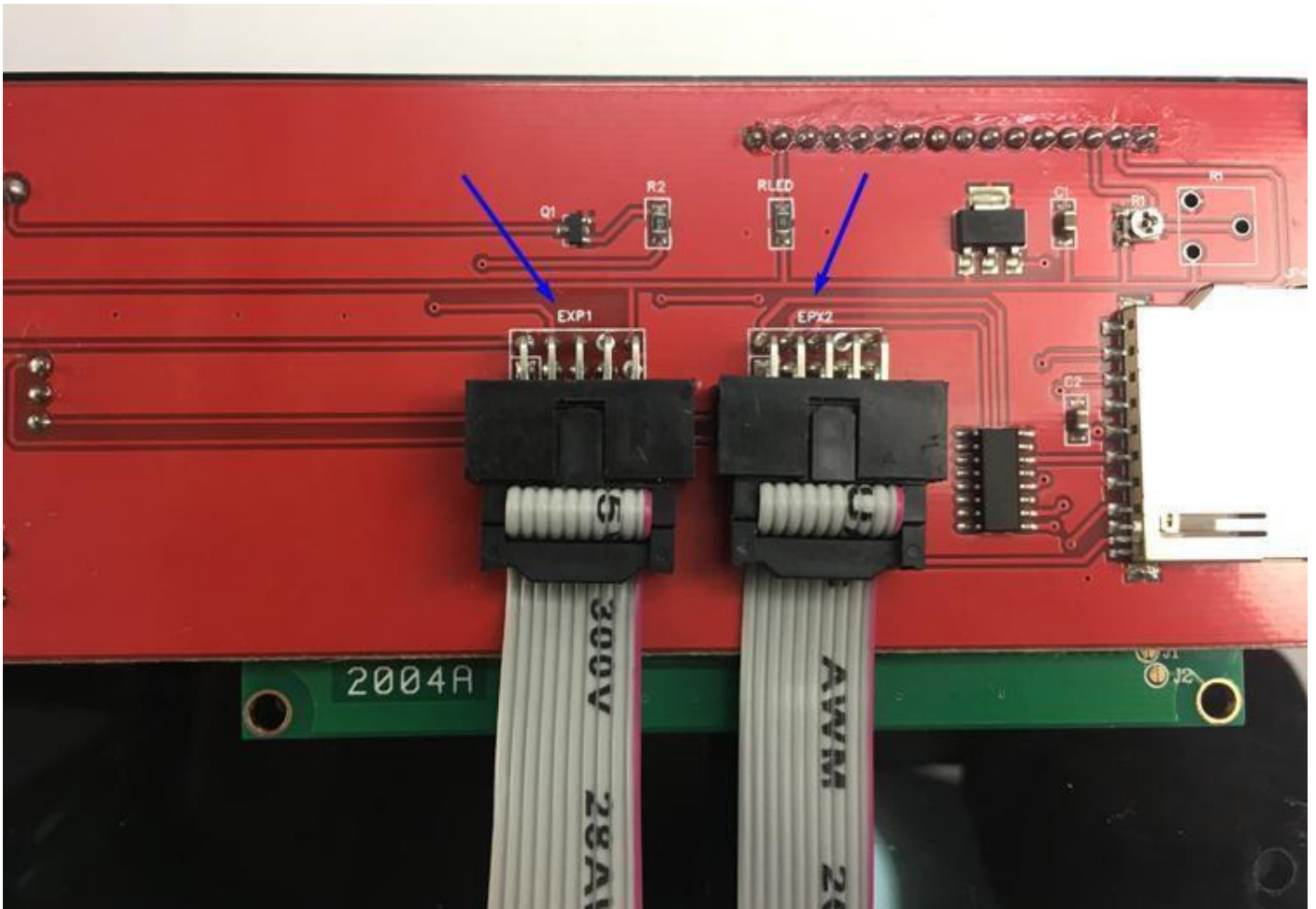

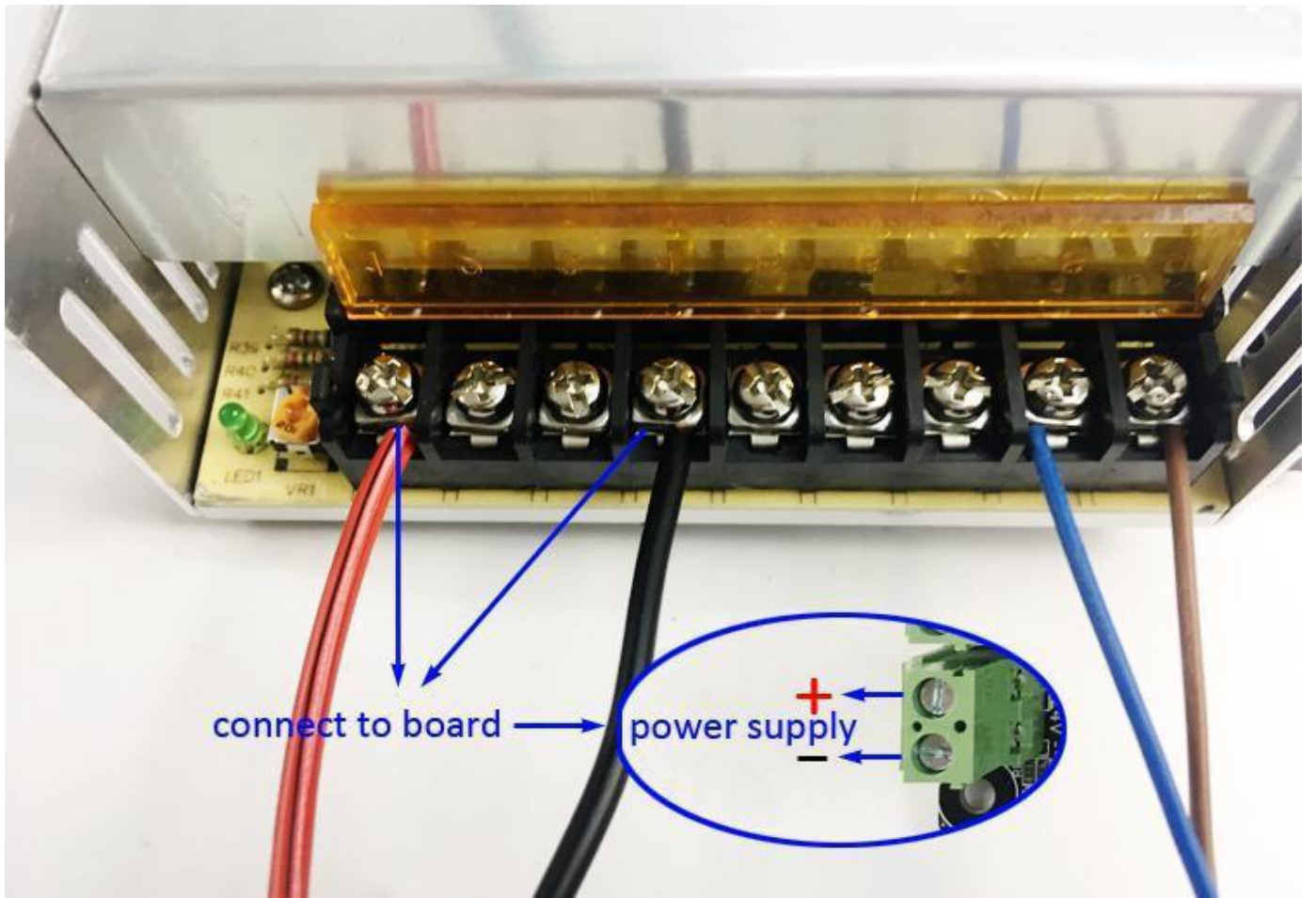

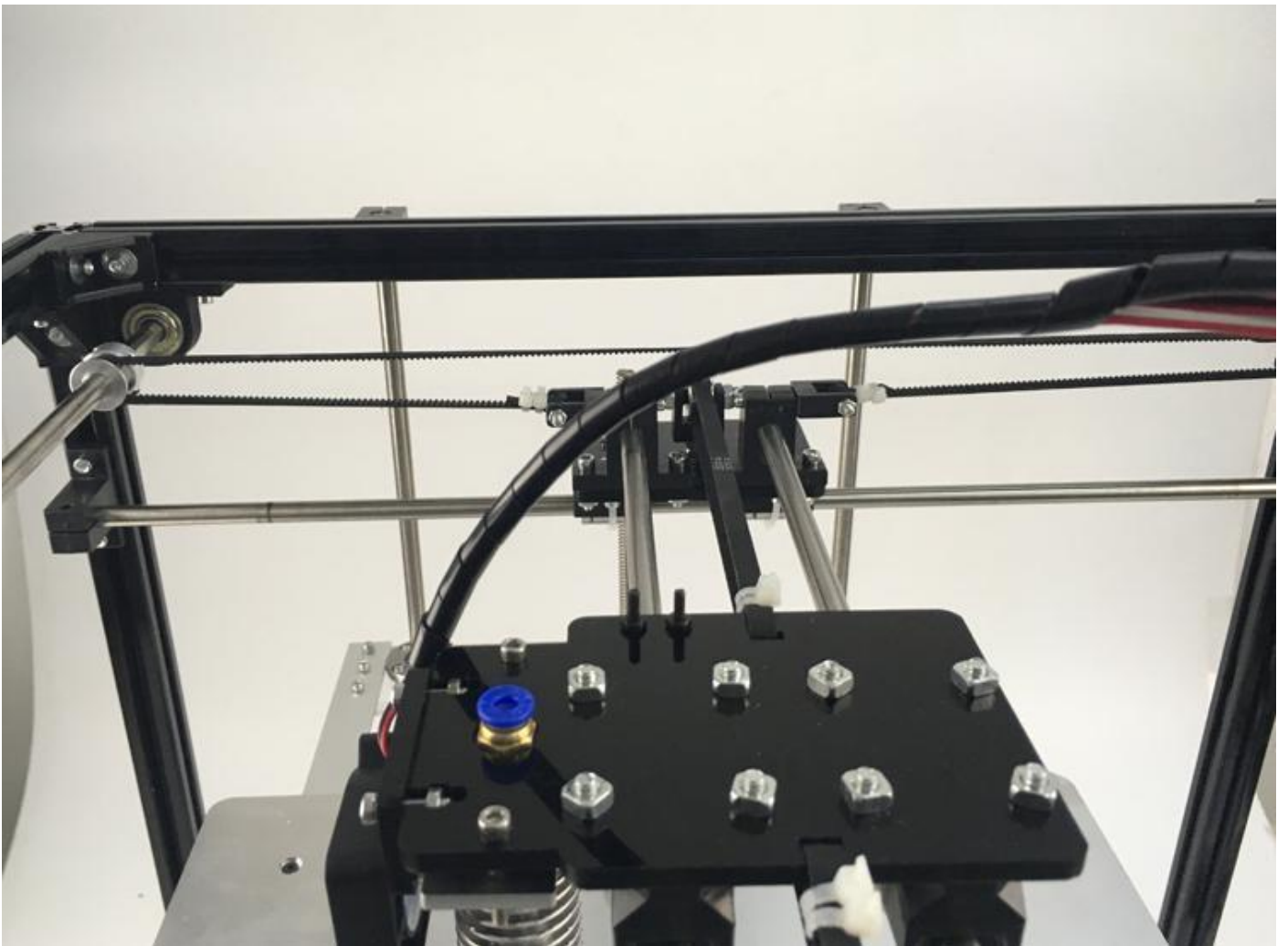
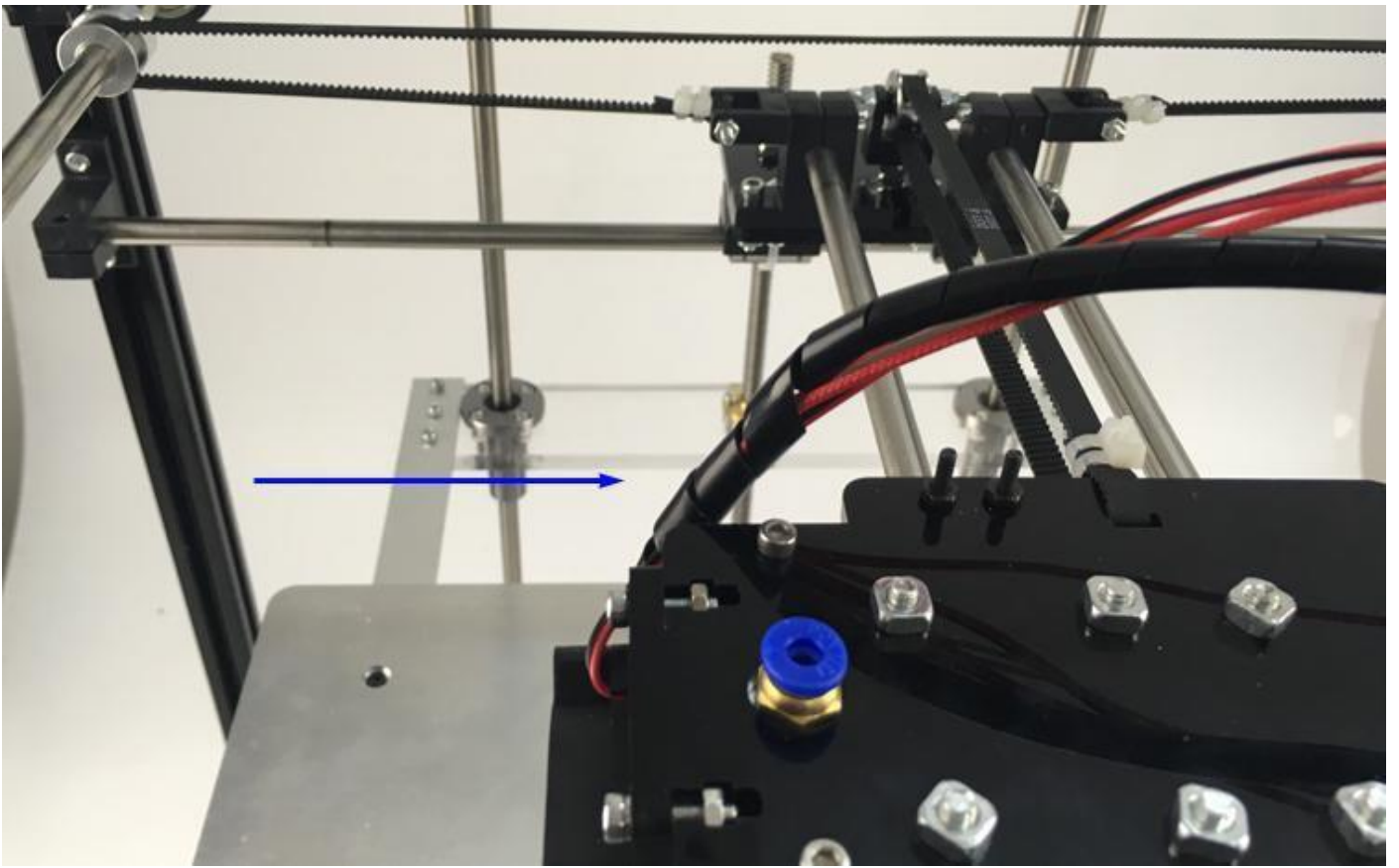

## filament support assembly

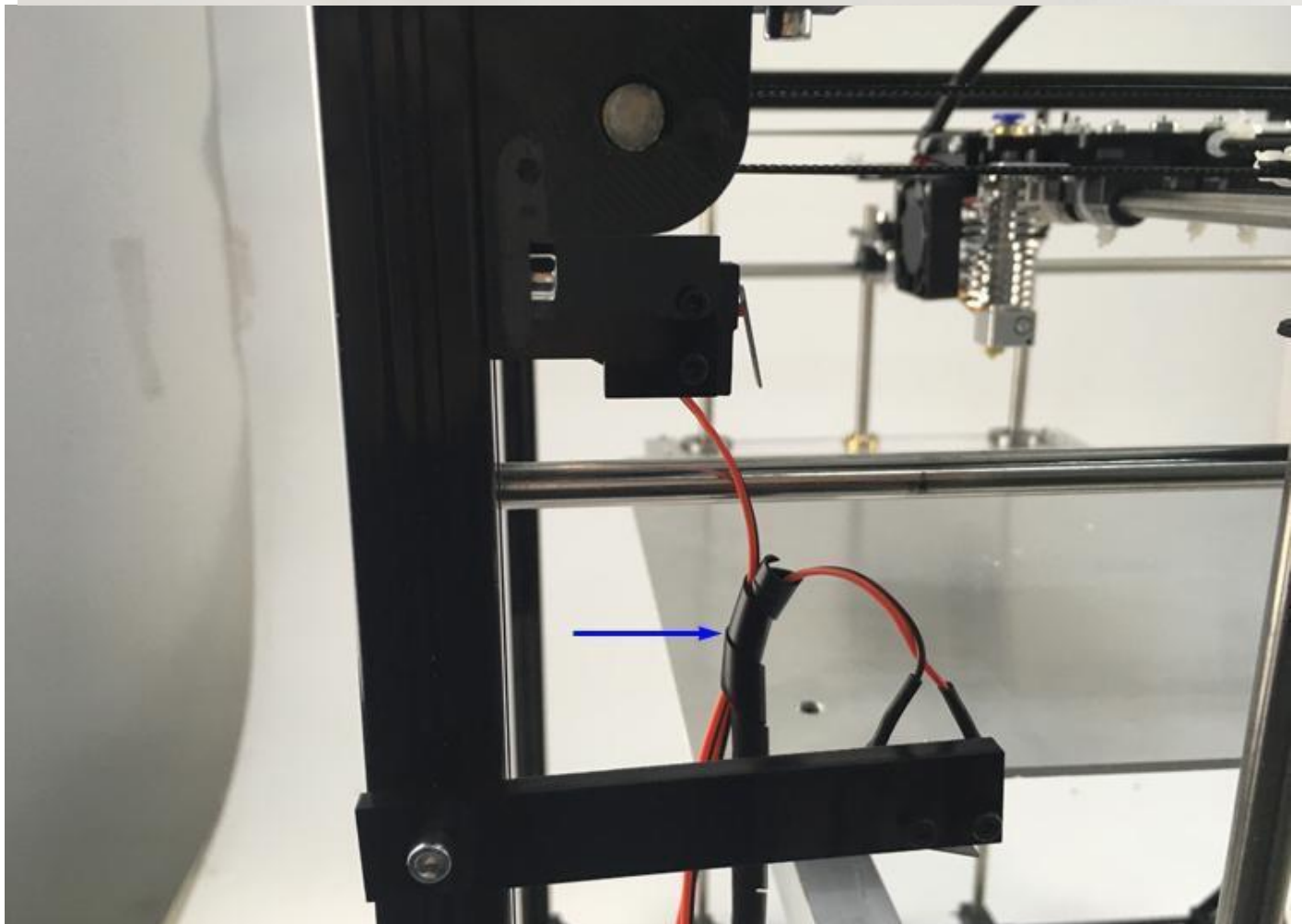
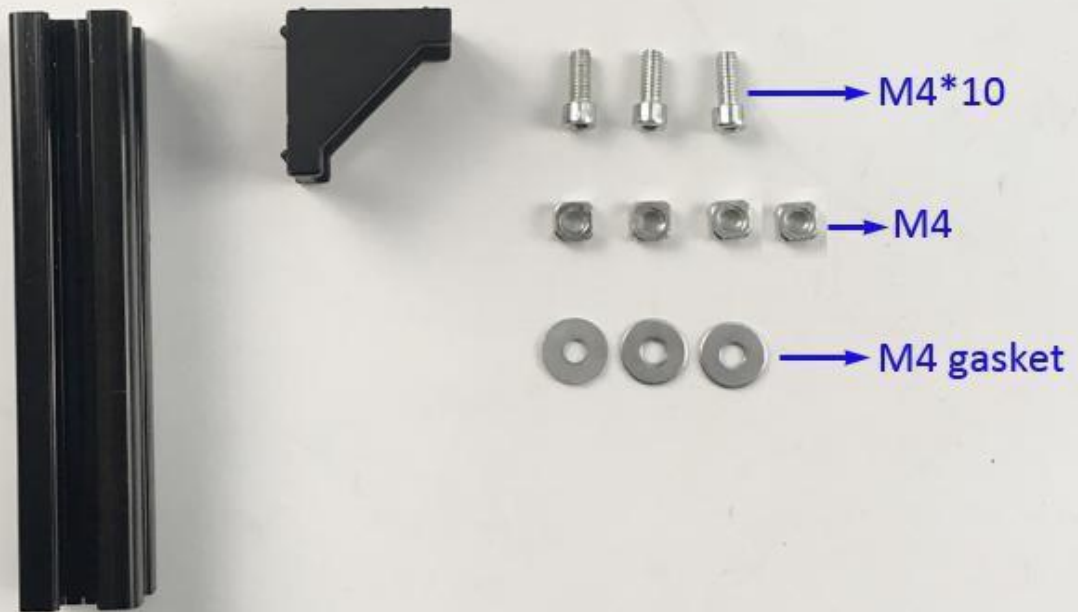

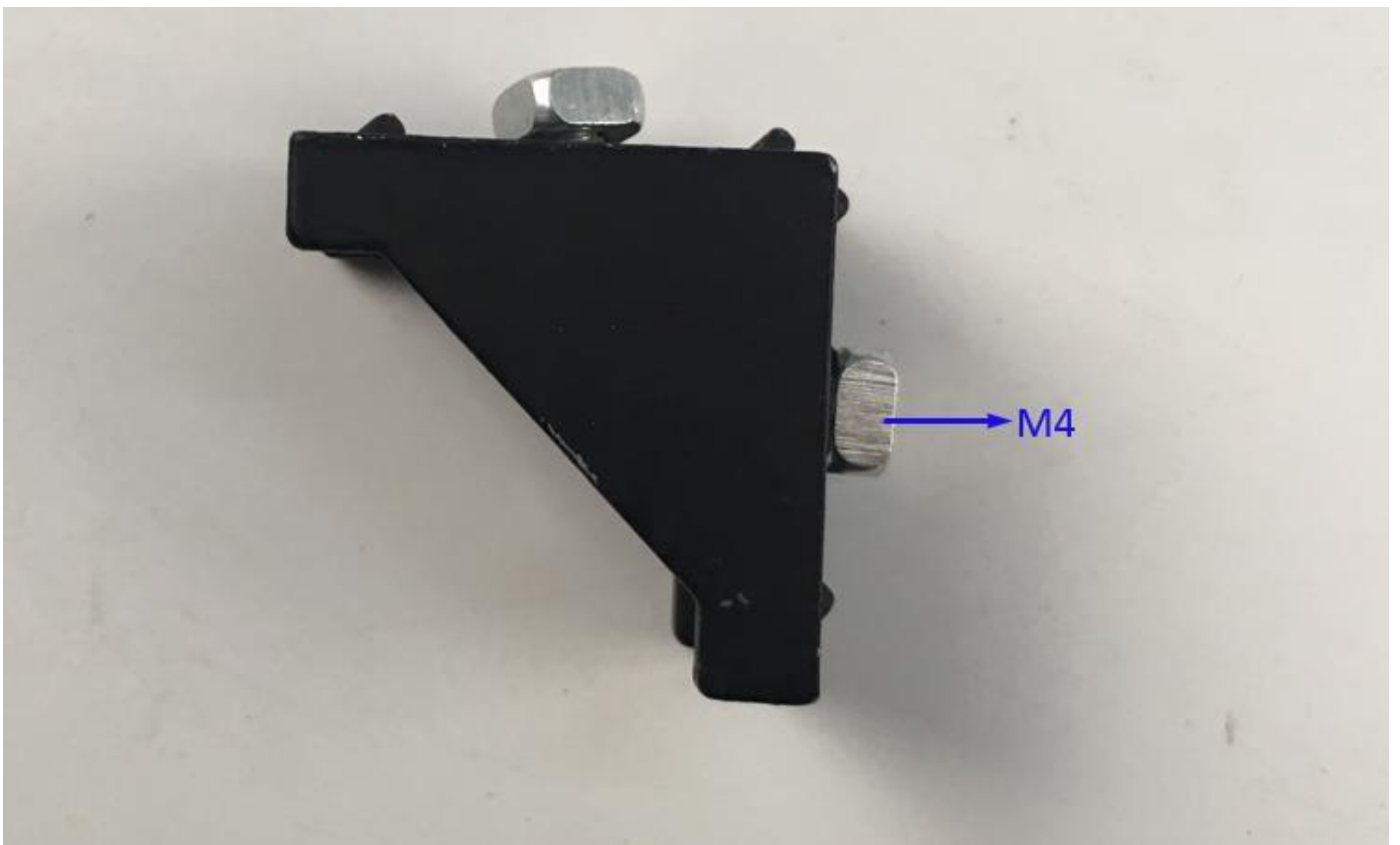





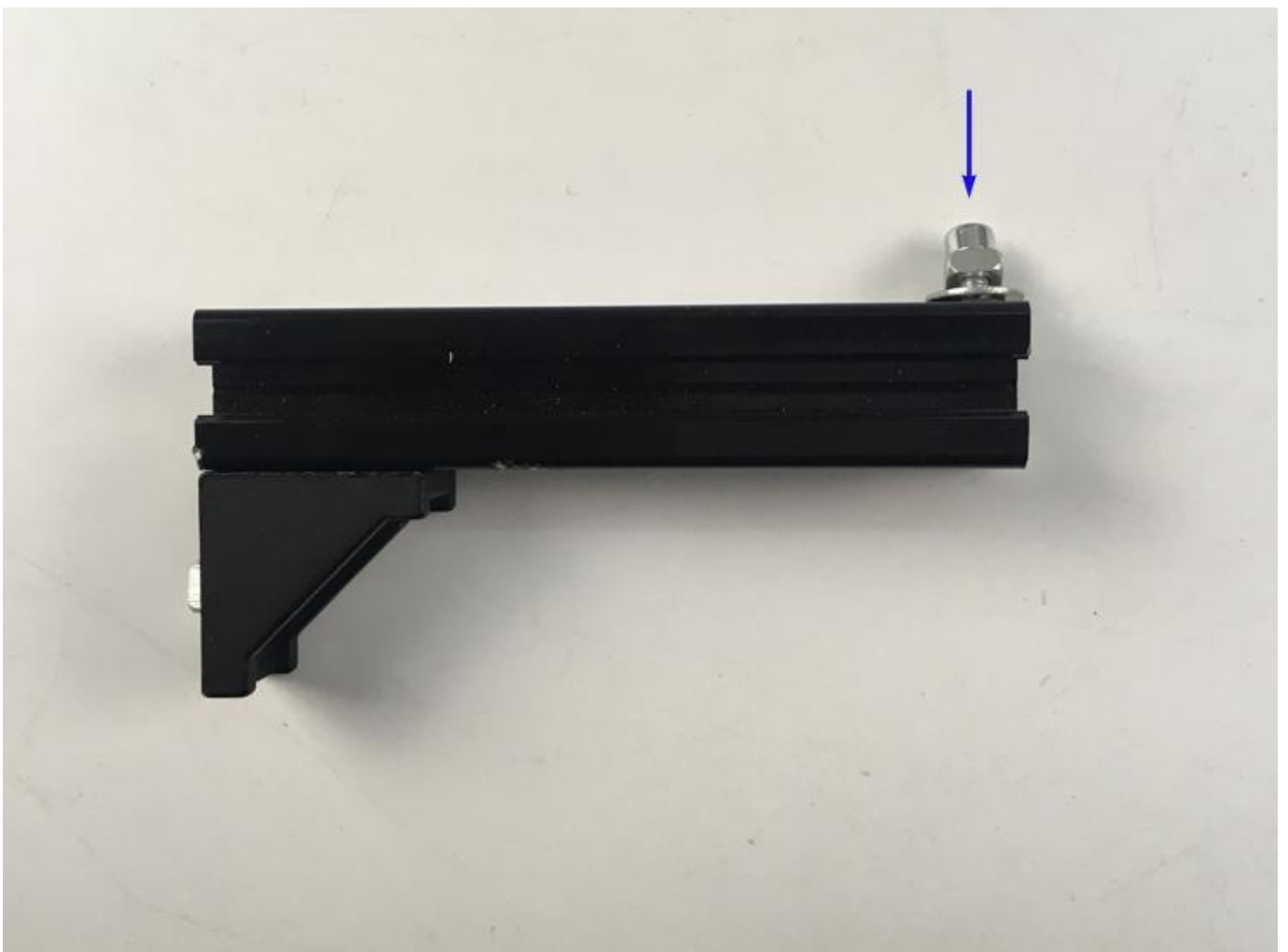
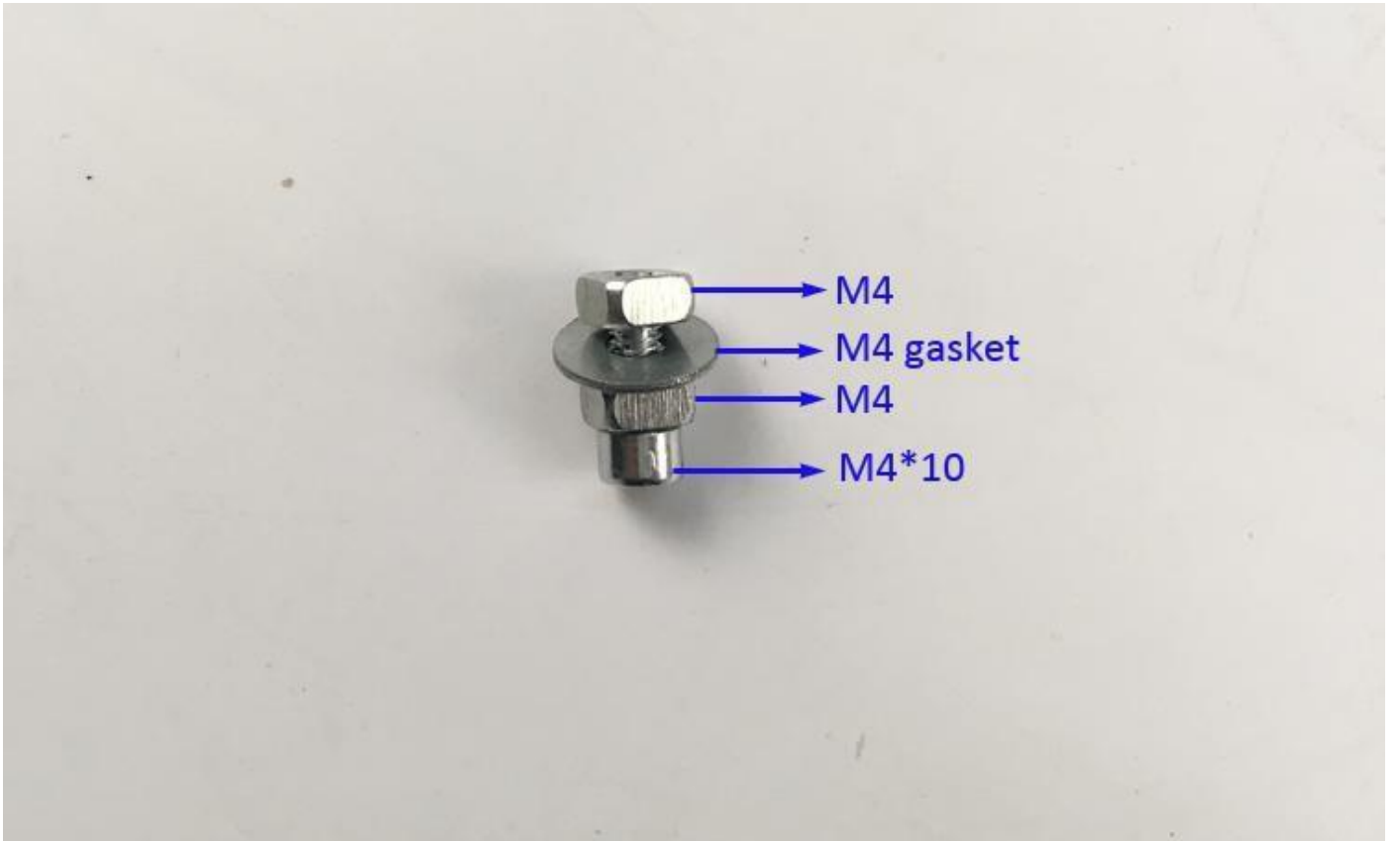

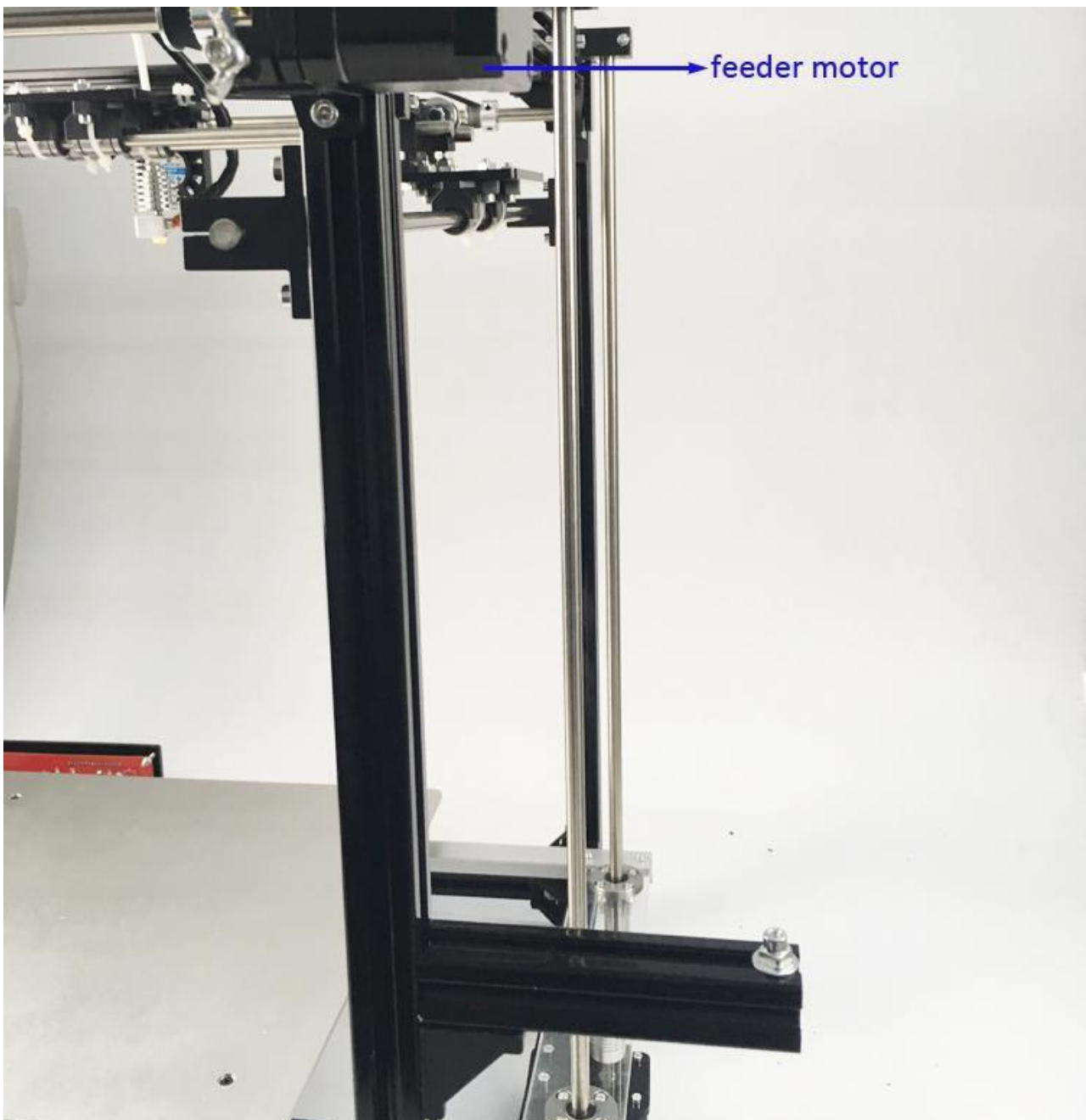

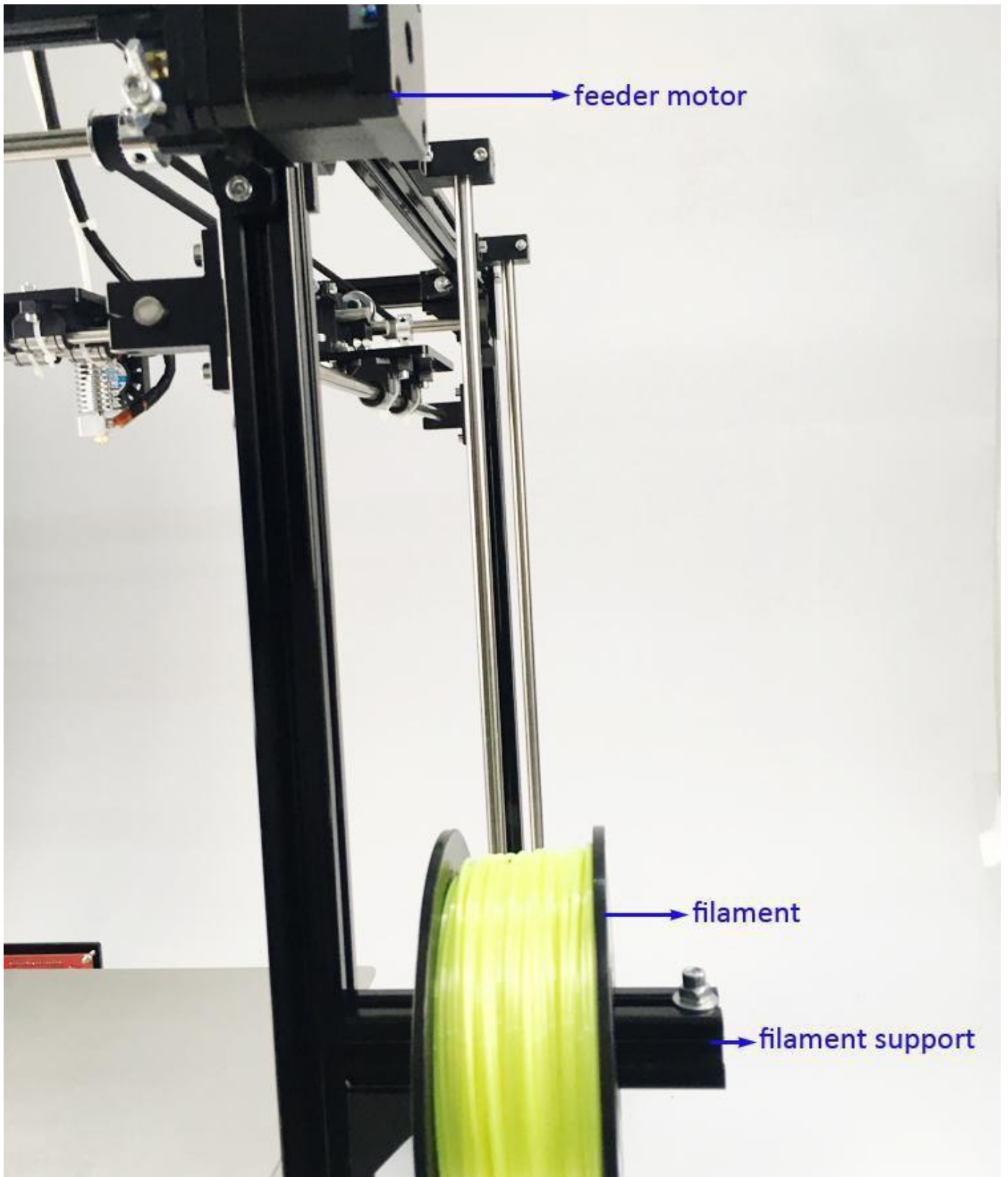

# key parts show

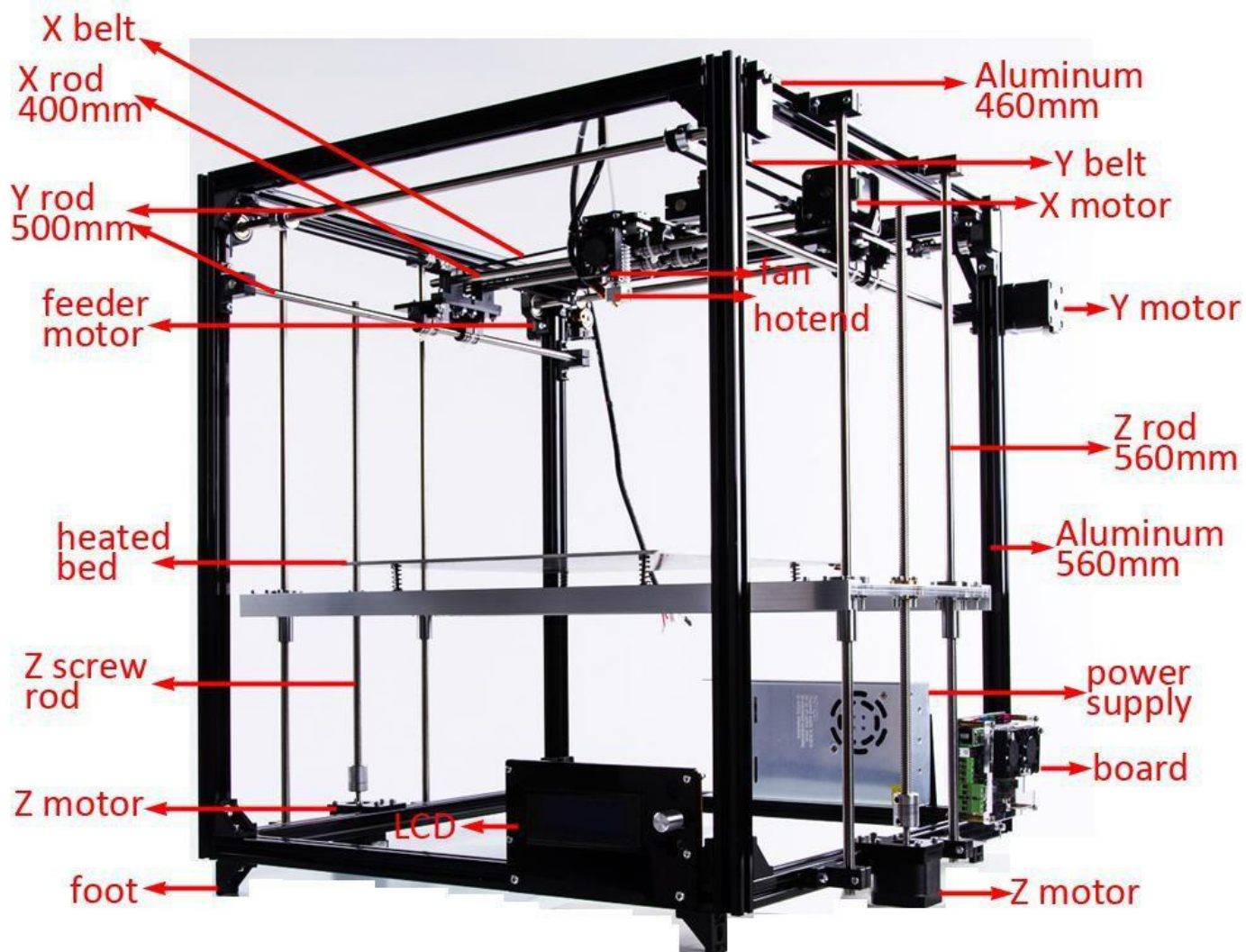

After assembly, please refer to the user manual for the printer to debug and print

Thank you